



LEICA SL3-P

INSTRUCTION MANUAL

FOREWORD

Dear Customer,

We wish you a great deal of fun and success taking photographs with your new Leica SL3-P. Please read this manual thoroughly to familiarize yourself with the full scope of functions your camera has to offer. You can find all information about the Leica SL3-P whenever you need it at <https://leica-camera.com>.

Your Leica Camera AG

SCOPE OF DELIVERY

Before using your camera for the first time, please check that the accessories supplied are complete.

- Leica SL3-P
- Lithium-ion rechargeable battery Leica BP-SCL6
- USB-C cable
- Camera bayonet cover
- Carry strap
- Quick Start Guide
- CE flyer
- Flyer (Leica account)
- Test certificate

Subject to changes in design and model features.

REPLACEMENT PARTS / ACCESSORIES

Please contact Leica Customer Care or visit the Leica Camera AG website for information on the extensive range of Leica replacement parts/accessories:

<https://leica-camera.com/en-US/photography/accessories>

Only the accessories specified and described in this manual or by Leica Camera AG must be used with the camera (battery, charger, mains plug, mains cable, etc.). These accessories must only be used with this product. Third-party accessories may result in malfunctions or damage to the product.

IMPORTANT TO NOTE BEFORE COMMISSIONING

Please read the chapters "Legal information", "Safety remarks", and "General information" before using your camera for the first time. Knowledge of the content will prevent inadvertent damage to the product, possible injuries and other risks.

Definition of the various categories of information found in this manual

Note

Additional information

Important

Failure to comply with instructions may result in damage to the camera, the accessories or the data files

Attention

Non-compliance may result in personal injury

LEGAL INFORMATION

COPYRIGHT NOTICE

- Compliance with copyright laws is mandatory. The recording and publication of pre-recorded media like tapes, CDs, or other published or broadcast material may breach copyright laws. The same applies for all software supplied as part of the scope of delivery.
- The following applies for all video material created with this camera: This product is governed by the AVC Patent Portfolio license and is meant for private use by a consumer only. The device may furthermore be used for purposes for which the consumer receives no remuneration, e.g. (i) encoding in accordance with the AVC Standard (“AVC Video”) and/or (ii) decoding of AVC Video that was encoded by a consumer in accordance with the AVC Standard within the scope of personal use and/or which the consumer has received from the provider, who is in possession of a license to offer AVC Video. No license is granted or implied for any other use. Any other use, specifically the provision of AVC video in exchange for remuneration, may require a separate license agreement with MPEG LA, L.L.C. Please visit the MPEG LA, L.L.C. website at: www.mpegla.com for more information.
- The designations SD, SDHC, SDXC, microSDHC and their associated logos are registered trademarks of SD-3C, LLC.

TRADEMARK NOTIFICATION

Microsoft® and Windows® are registered trademarks of Microsoft Corporation in the U.S. and/or other countries. Adobe®, Lightroom®, and Frame.io® are registered trademarks of Adobe Inc. in the U.S. and/or other countries. Capture One® is a registered trademark of Capture One A/S. Apple®, iOS®, macOS®, iPhone®, and iPad® are registered trademarks of Apple Inc. in the U.S. and/or other countries. App Store™ is a trademark of Apple Inc. Google Play™ is a trademark of Google LLC. All other trademarks are the property of their respective owners.

LEGAL INFORMATION ABOUT THIS MANUAL

COPYRIGHT

All rights reserved.

All text, images and graphics are subject to copyright and other laws to protect intellectual property. They must not be copied, modified or used for any purpose including trade purposes.

TECHNICAL DATA

Product changes with regards to the products or services may occur after the editorial deadline. The manufacturer reserves the right to effect structural or shape changes, color deviations and changes to the scope of delivery or service, where these changes or deviations are reasonably acceptable for the customer, while taking into consideration the interests of Leica Camera AG. To that extent, Leica Camera AG reserves the right to changes and errors. The images in this manual may depict accessory, special features or other items that are not part of the standard scope of delivery or service. Some pages may contain model types and services, which are not offered in specific countries.

BRANDS AND LOGOS

The brand names and logos used in this document are protected trademarks. These brands or logos must not be used without prior approval by Leica Camera AG.

LICENSE RIGHTS

Leica Camera AG intends to provide you with innovative and informative documentation. Due to the amount of creativity that has gone into its design, we ask for your understanding that Leica Camera AG must protect its intellectual property, including patents, trademarks and copyrights, and that possession of the documentation does not infer any licensing rights of the intellectual property of Leica Camera AG.

REGULATORY INFORMATION

You will find the manufacturing date of your camera on the stickers in the Warranty Card and/or on the packaging.

The date format is year/month/day.

COUNTRY-SPECIFIC LICENSES

Specific regional approvals for this device can be found in the camera menu.

- Select **Camera Information** in the main menu
- Select **Regulatory Information**

LICENSE INFORMATION

The device-specific license information can be found in the camera menu.

- Select **Camera Information** in the main menu
- Select **License Information**

CE MARK

The CE mark on our products documents compliance with the fundamental requirements of applicable EU guidelines.

Declaration of Conformity (DoC)
"Leica Camera AG" hereby declares that this product is in compliance with the basic requirements and other relevant provisions of Directive 2014/53/EU.
Customers can download a copy of the original DoC for our Radio Equipment products from our DoC server:
www.cert.leica-camera.com
Please contact Leica Camera AG, Am Leitz-Park 5, 35578 Wetzlar, Germany in case of any further questions
Usable frequency band/Usage limitations:
see Technical Data
Maximum output (e.i.r.p.): WLAN: <20 dBm / Bluetooth: <10 dBm

DISPOSAL OF ELECTRICAL AND ELECTRONIC EQUIPMENT

(Applies within the EU and for other European countries with active waste separation policies.)



This device contains electrical and/or electronic components which must not be disposed of in general household waste. Instead, it should be disposed of at a recycling collection point provided by your local authority.

This service is free of charge. Any standard or rechargeable batteries used in this device must be removed and disposed of separately in accordance with local regulations.

Please contact your local authorities, waste disposal collection point or the retailer, from whom you purchased the device for more information on correct waste disposal.

IMPORTANT NOTES REGARDING THE USE OF WLAN/BLUETOOTH®

- Appropriate measures must be taken to ensure security and protect against disruptions to the systems in place where devices or computer systems are in use that require more stringent security than WLAN devices.
 - Leica Camera AG shall not accept liability for damages arising from the use of the camera for purposes other than as a WLAN device.
 - It is assumed that the WLAN function will be used in countries where this camera is sold. There may be a risk of breaching statutory wireless communication regulations when using the camera in other countries. Leica Camera AG shall not accept liability for such breaches.
 - Please note that there is a risk of unauthorized third party interception of wirelessly communicated data. We highly recommend that you activate encryption in the wireless access point settings to ensure data safety.
 - Avoid using the camera in areas where it can be exposed to magnetic fields, static electricity or other interferences, e.g. near a microwave oven. RF transmissions may otherwise not reach the camera.
 - Using the camera near devices like microwave ovens or mobile phones that use the 2.4 GHz RF band may negatively affect the performance of both devices.
 - Do not attempt to connect to wireless networks you are not authorized to use.
 - The device will automatically search for wireless networks, once the WLAN function is enabled. A list, including networks you are not authorized to access, will be displayed (SSID: Network identifier for a WLAN network). Do not attempt to connect to third party network, as this could be construed as unauthorized access.
 - We recommend disabling the WLAN function while on an aircraft.
- The use of the WLAN-RF band between 5150 MHz and 5350 MHz is permitted only in enclosed spaces.
 - Please read the important notes on specific functions of Leica FOTOS on p. 292.

SAFETY REMARKS

GENERAL INFORMATION

- Do not use your camera in the immediate vicinity of devices that generate powerful magnetic, electrostatic or electromagnetic fields (e.g. induction ovens, microwave ovens, television sets or computer screens, video game consoles, cell phones, broadcasting equipment). Their electromagnetic fields can interfere with image capturing.
- Strong magnetic fields, e.g. from speakers or large electric motors can damage the stored data or disrupt shooting.
- Switch off the camera, remove the battery briefly, replace it and switch the camera back on in case of a camera malfunction due to the effects of electromagnetic fields.
- Do not use the camera in the immediate vicinity of radio transmitters or high-voltage power lines. Their electromagnetic fields may also interfere with image capturing.
- Always store small parts e.g. the accessory shoe cover as follows:
 - out of the reach of children
 - in a safe location, where they will not get lost or stolen
- State-of-the-art electronic components are sensitive to static discharge. You can easily pick up charges of several 10,000 volts by simply walking on synthetic floor coverings. A static discharge can occur when you touch the camera and especially if it is placed on a conductive surface. A static discharge on the camera housing poses no risk for the electronics. Despite built-in safety circuits, you should avoid direct contact with external camera contacts like those in the hot shoe.
- Take care not to soil or scratch the sensor for lens detection in the bayonet. You must similarly prevent direct contact of the bayonet with grains of sand or similar particles, as these could cause irreparable

damage. This component must only be cleaned with a dry cloth (in system cameras).

- Use a cotton or linen cloth instead of a microfiber cloth from an optician's (synthetic) when cleaning the contacts. Make sure to discharge any electrostatic charge by deliberately touching a heating or water pipe (conductive, grounded material). Dirt deposits and oxidation on the contacts can be avoided by storing your camera in a dry location with the lens cap and the flash shoe/viewfinder cap (in system cameras) attached.
- Only use accessories specified for this model to prevent faults, short circuits or electric shock.
- Do not attempt to remove parts of the housing (covers) yourself. Repairs must be done at authorized service centers only.
- Protect the camera against contact with insect sprays and other aggressive chemicals. Petroleum spirit, thinner and alcohol must not be used for cleaning. Some chemicals and liquids can damage the camera housing or the surface finish.
- Rubber and plastics are known to expel aggressive chemicals and should therefore not be kept in contact with the camera for extended periods of time.
- Prevent any sand or dust or water penetration into the camera, e.g. during snowfall or rain or on the beach. Be extra careful when changing the lens (in system cameras) and when inserting or removing the memory card and rechargeable battery. Sand and dust can damage the camera, the lens, the memory card and the battery. Moisture can cause malfunctions and irreparable damage to the camera and memory card.

LENS

- A camera lens can have the effect of a magnifying glass when exposed to intense frontal sunlight. The camera must therefore be protected against extended exposure to direct sunlight.

- Attaching the lens cap and keeping the camera in the shade or ideally in its camera case, will help prevent damage to the interior of the camera.
- The use of other chargers not approved by Leica Camera AG can cause damage to the batteries – and in extreme cases – cause serious or life-threatening injuries.

RECHARGEABLE BATTERY

- Improper use of the batteries or the use of unapproved battery types may result in an explosion!
- Do not expose the rechargeable battery to sunlight, heat, humidity or moisture for prolonged periods of time. Likewise, the batteries must not be placed in a microwave oven or a high-pressure container as this would pose a fire or explosion hazard!
- Do not under any circumstances charge or insert a damp or wet battery into the camera!
- A safety valve in the battery ensures that any excess pressure caused by improper handling is discharged safely. It is nevertheless important to dispose of a bloated battery immediately. It may pose an explosion hazard!
- Keep the battery contacts clean and easily accessible. Although lithium-ion rechargeable batteries are secured against short circuits, they should still be protected against contact with metal objects like paper clips or jewelry. A short-circuited battery can get very hot and cause severe burns.
- When a battery is accidentally dropped, make sure to check the housing and the contacts immediately for any damage. A damaged battery can damage the camera.
- The battery must be removed from the camera or charger and must be replaced immediately in case of a strange smell, discoloration, deformation, overheating or leakage. Continued use of the battery may result in overheating, which can cause fire and/or explosion!
- Never throw batteries into a fire as they may explode.
- Keep the battery away from sources of heat in case of leakage or if you smell burning. Leaked fluid can catch fire!

- Make sure that the power socket is freely accessible at all times.
- Do not attempt to open the battery or the charger. Repairs must only be carried out by authorized workshops.
- Keep batteries out of the reach of children. Batteries can cause suffocation when swallowed.

FIRST AID

- Battery fluid may cause blindness if it comes into contact with the eyes. Rinse the eyes thoroughly with clean water immediately. Avoid rubbing. Seek medical attention immediately.
- Leaked battery fluid poses an injury hazard when it comes in contact with clothing or skin. Rinse the affected areas thoroughly with clean water.

CHARGER

- Using the charger in the vicinity of broadcasting receivers may interfere with reception. Ensure a distance of at least 1 m between the charger and the receiver.
- When the charger is in use, it may emit a buzzing sound – that is normal and not a malfunction.
- Disconnect the charger from the mains when it is not in use, as it consumes electricity (a very small amount), even if no battery is inserted.
- Always keep the charger contacts clean, and never short-circuit them.

MEMORY CARD

- Never remove the memory card during a data save or card reading process. The camera must not be

switched off or be subjected to impact or vibrations while working.

- Do not open the cover/remove the memory card or the battery from the camera while the status LED is lit, which indicates memory access. Data on the card may otherwise be destroyed and camera malfunctions may occur.
- Do not drop or bend memory cards as this will cause damage and result in the loss of stored data.
- Do not touch the connections on the reverse of the memory card and keep them clean and dry.
- Keep memory cards out of the reach of children. Swallowing a memory card may cause suffocation.

SENSOR

- Cosmic radiation (e.g. during flights) may cause pixel defects.

CARRY STRAP

- Carry straps are usually made of very robust material. You should therefore keep it out of the reach of children. A carry strap is not a toy and poses a strangulation risk.
- Use the carry strap only for its intended purpose on a camera or on binoculars. Any other use poses the risk of injury and may possibly result in damage to the carry strap and is therefore not permitted.
- Carry straps should also not be used for cameras/binoculars during sports activities that pose a risk of entanglement (e.g. when mountain climbing and similar outdoor activities).

TRIPOD

- When using a tripod, make sure it is standing securely and turn the camera only by turning the tripod, not the actual camera. Ensure that the tripod screw is hand-tightened only. Avoid transporting the camera while the tripod is attached. You might injure yourself or others, and the camera could suffer damage.

FLASH

- The use of incompatible flash units with your Leica SL3-P may result in irreparable damage to the camera and/or the flash unit.

GENERAL INFORMATION

Please read the section about “Care/Storage” for more information about what to do in case of problems.

CAMERA/LENS

- Make a note of the serial numbers of your camera (engraved in the base of the camera housing) and lenses, as this information will be extremely important in case of loss.
- Make sure to always have a lens or the camera bayonet cover attached to prevent dust or other foreign bodies penetrating the camera.
- That is why you should always replace lenses quickly and in a dust-free environment.
- Never store the camera bayonet cover or the lens back cover in a pants pocket, as they will attract lint and dust, which could then be accidentally introduced into the camera.

LCD PANEL

- Condensation may form on the LCD panel if the camera is exposed to great temperature fluctuations. Wipe the screen carefully with a soft, dry cloth.
- The screen image will initially be slightly darker than normal if the camera is very cold when it is switched on. The normal level of brightness will be reached as soon as the LCD panel warms up.

RECHARGEABLE BATTERY

- For safety reasons, the battery is only minimally charged on delivery. The battery must be activated with an initial charge before first use.



- The rechargeable battery must only be charged within a specific temperature range. See chapter

“Technical Data” (p. 326) for details about operating conditions.

- Lithium-ion batteries can be charged at any time, regardless of their current charge level. A partially charged battery will charge to full capacity faster than a fully discharged one.
- The rechargeable batteries come only partly charged ex works and should therefore be charged fully before their first use.
- A new battery only reaches its full capacity after it has been fully charged and – by using it in the camera – depleted 2 to 3 times. This depletion process should be repeated roughly every 25 cycles.
- Battery and charger heat up during the charging process. That is normal and not a malfunction.
- Rapid flashing of the two LEDs (> 2 Hz) when charging commences indicates a charging error (e.g. maximum charging time exceeded, voltages or temperatures outside permitted ranges or a short circuit). Disconnect the charger from the mains and remove the battery. Ensure that the above temperature conditions are met and then restart the charging process. Please contact your dealer, the Leica representative in your region or Leica Camera AG if the problem persists.
- Rechargeable lithium-ion batteries generate power by way of internal chemical reactions. These reactions are influenced by ambient temperature and humidity. Do not expose the battery to extreme temperatures (high or low) for extended periods of time (e.g. in a parked car in the summer or winter) to ensure a maximum service life.
- However, every battery has its limits – even in optimal conditions! After several hundred charging cycles, the operating times will get significantly shorter.
- The replaceable battery supplies power to a backup battery, which is permanently installed in the camera. This backup battery retains the date and time for some weeks. Once the backup battery is depleted, it must be replenished by inserting a charged main battery. The time and date will have to be set again after a full depletion of both batteries.

- As the battery capacity deteriorates or if using an older battery, warning messages may appear and some functions may be restricted or blocked entirely.
- Always remove the battery if the camera will not be used for an extended period of time. Make sure to switch the camera off via the main switch before removing the battery. Leaving the battery in the camera will result in a deep discharge after a few weeks. Voltage levels will decrease significantly, as the camera uses a low idle current to maintain settings.
- Dispose of damaged batteries in accordance with the relevant regulations at an approved collection point for proper recycling.
- The date of manufacture can be found on the battery. The date format is week/year.

MEMORY CARD

- The range of available SD-/SDHC-/SDXC/ CFe Type B cards on the market is too extensive for Leica Camera AG to test for compatibility and quality. Generally, any type of memory card may be used without any damage to the camera or memory card. As some “no name” cards may not fully comply with the SD/SDHC/SDXC standards, Leica Camera AG cannot provide any guarantee of function.
- We recommend formatting memory cards from time to time, as fragmented residual data from deleted files may block some of the storage capacity.
- Generally, it is not necessary to format (initialize) memory cards that have been previously used. Formatting will, however, be necessary if you insert an unformatted memory card or a card that was formatted in another device (e.g. a computer) for the first time.
- We recommend backing up your data on a PC, because electromagnetic fields, static electricity and any damage to the memory card or camera defects may result in irretrievable damage or loss of your data.
- SD-/SDHC-/SDXC/ CFe Type B memory cards come with a write protection slider to prevent accidental

overwriting. This slider is located on the non-beveled side of the card. All data on the card is protected when the slider is set to its lower position, marked LOCK.

- All data stored on the memory card will be lost during formatting. Formatting will not be prevented by a deletion protection set for individual shots.



CAUTION: HOT MEMORY CARD

As depicted on the inside of the card compartment, the memory card may be hot directly after use by the camera. Be careful when removing the card! Do not remove the memory card directly if a high temperature warning is displayed on screen. Instead, please wait until the message is no longer displayed before removing the card.

SENSOR

- Depending on particle size, any dust or dirt particles adhering to the sensor glass may result in noticeable dark spots or blemishes in recordings (in system cameras). Alternatively, send your camera to the Leica Customer Care department for sensor cleaning (see p. 332). This service is not part of the warranty offering and will therefore incur charges.

DATA

- All data, including personal information, may be changed or deleted due to incorrect or accidental operation, static discharge, accidents, malfunctions, repairs and other actions.
- Please note that Leica Camera AG does NOT accept liability for direct or consequential damage due to the manipulation or destruction of data and personal information.

FIRMWARE UPDATE

Leica is continuously working on the further improvement and optimization of Leica SL3-P. As digital cameras have many functions that are controlled electronically, improvements and enhancements to the functions can be installed on the camera retroactively. Leica releases so-called firmware updates at irregular intervals. Cameras are always supplied ex works with the latest firmware installed or you can download the latest version from our website yourself and transfer it to your camera.

You will receive a newsletter informing you of the availability of a new firmware update if you register your camera on the Leica Camera homepage.

Visit the download section or the "Customer Area" for information about how to register or how to get firmware updates for your Leica SL3-P. Additionally, you can find information about changes or additions to the manual at: <https://club.leica-camera.com>

Leica releases firmware updates for lenses at irregular intervals. You can download any new firmware version from our homepage and transfer it to your lens. Please see p. 296 for more information.

Select the menu item **Camera Information** (see p. 295) to check whether your camera and lenses are running the latest firmware version.

WARRANTY TERMS LEICA CAMERA AG

Dear Leica Customer,
congratulations on the purchase of your new Leica product – you are now the proud owner of a world-class brand product.

In addition to your statutory warranty claims against your seller, we, Leica Camera AG ("LEICA"), grant you voluntary warranty services for your Leica product in accordance with the following stipulations ("Leica Warranty"). The Leica warranty therefore does not limit your statutory rights as a consumer under applicable law or your rights as a consumer against the dealer with whom you have concluded the purchase contract.

LEICA WARRANTY

You have purchased a Leica product that has been manufactured according to special quality guidelines and tested by experienced specialists during the various stages of production. We provide the following Leica Warranty, valid as of April 1, 2023, for this Leica product and including the accessory parts in the original packaging. Please note that we do not offer any warranty for commercial use.

We offer an extended warranty for some Leica products, provided you register for a Leica Account. Please visit www.leica-camera.com for more details.

LEICA WARRANTY SCOPE

During the warranty period, complaints based on manufacturing and material defects will be remedied free of charge, at LEICA's discretion, by way of repair, replacement of defective parts, or exchange for a similar Leica product in perfect condition. Replaced parts or products become the property of LEICA.

Further claims of any kind and on any legal grounds whatsoever in connection with this Leica Warranty are excluded.

EXCLUDED FROM THE LEICA WARRANTY

Parts subject to wear and tear (e.g. eyecups, leather coverings, carry straps, armoring, batteries), and parts under mechanical stress are excluded from the Leica Warranty, unless the defect was caused by manufacturing or material defects. That also applies to any exterior damage.

VOIDED CLAIMS UNDER LEICA WARRANTY

Claims under the warranty are void if the defect in question is due to improper handling; they may also be void if e.g. third-party accessories have been used, the Leica product has not been opened professionally or has not been repaired professionally. Claims for warranty services shall similarly be void if the serial number is unrecognizable.

CLAIMS UNDER THE LEICA WARRANTY

We require a copy of the proof of purchase of your Leica product from a LEICA-authorized dealer ("Authorized Leica Dealer") before we can accept any claim under the warranty. The purchase receipt must show the date of purchase, the Leica product with its article number and serial number, and details of the Authorized Leica Dealer. We reserve the right to request the original receipt. Alternatively, you may send us a copy of the warranty card; please note that the Warranty Card must be filled out correctly, and the product must have been purchased from an Authorized Leica Dealer.

Please send your Leica product with a copy of your purchase receipt or the Warranty Card alongside a description of the issue.

Leica Camera AG, Customer Care, Am Leitz-Park 5, 35578 Wetzlar, Germany

Email: customer.care@leica-camera.com

Phone: +49(0)6441 2080-189

or to an Authorized Leica Dealer.

| Leica Product Image | Warranty Term |
|---------------------|---------------|
| all products | 2 years |

Leica SL3-P comes with splash water and dust protection.

The camera was tested under controlled laboratory conditions and is classed as IP54 in accordance with DIN EN 60529. Please note: The splash water and dust protection coating is not permanent and will diminish over time. Please read the section on "Care/Storage" for detailed instructions on how to clean and dry the camera. The warranty does not cover liquid damage. Any attempt to open the camera casing by an unauthorized retailer or service partner will cause an immediate expiration of the splash water and dust warranty.

TABLE OF CONTENTS

| | |
|---|----|
| FOREWORD | 2 |
| SCOPE OF DELIVERY | 2 |
| REPLACEMENT PARTS / ACCESSORIES | 3 |
| IMPORTANT TO NOTE BEFORE COMMISSIONING | 3 |
| LEGAL INFORMATION | 4 |
| TRADEMARK NOTIFICATION | 4 |
| SAFETY REMARKS | 8 |
| GENERAL INFORMATION | 11 |
| WARRANTY TERMS LEICA CAMERA AG | 14 |
| TABLE OF CONTENTS | 16 |
| PART DESIGNATIONS | 22 |
| DISPLAYS | 26 |
| PHOTO | 26 |
| VIDEO/CINE | 28 |
| DISPLAYS IN THE TOP DISPLAY | 30 |
| PREPARATION | 32 |
| ATTACHING THE CARRY STRAP | 32 |
| PREPARING THE CHARGER | 32 |
| CHARGING THE BATTERY | 33 |
| CHARGING VIA USB | 34 |
| INSERTING/REMOVING THE BATTERY | 34 |
| INSERTING/REMOVING THE MEMORY CARD | 36 |
| LENSES | 38 |
| COMPATIBLE LENSES | 38 |
| COMPENSATION PROFILES FOR ANARMOPHIC LENSES | 39 |
| CHANGING THE LENS | 40 |
| DIOPTR SETTINGS | 43 |
| MULTIFUNCTION HANDGRIP HG-SCL7 | 44 |
| CAMERA OPERATION | 50 |
| CONTROL ELEMENTS | 50 |

| | |
|--|----|
| MAIN SWITCH | 50 |
| MAIN SWITCH LED | 51 |
| SHUTTER BUTTON | 52 |
| LEFT DIAL | 53 |
| RIGHT DIAL | 53 |
| THUMBWHEEL | 54 |
| JOYSTICK | 54 |
| PLAY BUTTON/MENU BUTTON | 55 |
| LCD PANEL | 55 |
| LCD PANEL (TOUCH SCREEN) | 57 |
| FUNCTION BUTTONS | 58 |
| TOP DISPLAY | 59 |
| MENU CONTROL | 59 |
| CONTROL ELEMENTS | 59 |
| MENU SECTIONS | 60 |
| SETTINGS IN PHOTO AND VIDEO MODE | 61 |
| SWITCHING MENU SECTIONS | 62 |
| CONTROL CENTER | 63 |
| CUSTOMIZING THE CONTROL CENTER | 63 |
| MAIN MENU | 64 |
| MENU NAVIGATION | 65 |
| SUBMENU | 67 |
| KEYBOARD/NUMBER PAD | 67 |
| MENU BAR | 68 |
| SCALE MENU | 69 |
| DATE/TIME MENU | 69 |
| COMBI MENU (AF PROFILES) | 70 |
| COMBI MENU (LEICA LOOKS) | 70 |
| USER-DEFINED OPERATION | 72 |
| DIRECT ACCESS TO MENU FUNCTIONS | 72 |
| CHANGING AN ASSIGNMENT | 72 |
| ACCESSING THE ASSIGNED MENU FUNCTION | 72 |
| DIAL ASSIGNMENTS | 73 |
| WHEN USING AF LENSES | 74 |
| WHEN USING MF LENSES | 75 |
| ROTATION DIRECTION OF THE DIALS | 75 |
| JOYSTICK FUNCTIONS | 76 |
| LOCKING THE OPERATING ELEMENTS | 76 |
| USER PROFILES | 77 |

| | | | |
|---|-----------|--|------------|
| CAMERA BASIC SETTINGS | 80 | IMAGE STABILIZATION | 93 |
| MENU LANGUAGE | 80 | SETTING THE STABILIZATION DIRECTION | 94 |
| DATE/TIME | 80 | DARK AREA OPTIMIZATION (IDR) | 95 |
| DISTANCE UNIT | 81 | DYNAMIC RANGE | 95 |
| POWER SAVE MODE (STANDBY MODE) | 82 | iDR FUNCTION | 95 |
| LCD PANEL/VIEWFINDER SETTINGS | 82 | DATA MANAGEMENT | 96 |
| LCD PANEL/EVF USE | 83 | STORAGE OPTIONS | 96 |
| EYE SENSOR SENSITIVITY | 83 | FORMATTING A MEMORY CARD | 96 |
| BRIGHTNESS | 84 | FORMATTING AN EXTERNAL USB SSD | 97 |
| LCD PANEL | 84 | EXTERNAL DATA MEDIUM | 98 |
| EVF | 84 | DATA STRUCTURE | 98 |
| COLOR RENDERING | 84 | EDIT FILE NAMES | 99 |
| LCD PANEL | 84 | CREATING A NEW FOLDER | 100 |
| EVF | 84 | CONTENT CREDENTIALS | 100 |
| AUTOMATIC LCD PANEL AND EVF SHUTDOWN | 85 | LOGGING THE SHOOTING LOCATION | 101 |
| EVF FRAME RATE | 85 | DATA TRANSFER | 102 |
| LCD FRAME RATE | 85 | PRACTICAL DEFAULT SETTINGS | 104 |
| AUTOMATIC ROTATION OF THE INFO BAR | 85 | TOUCH AF | 104 |
| ACOUSTIC SIGNALS | 86 | TOUCH AF + SHUTTER BUTTON | 105 |
| VOLUME | 86 | TOUCH AF IN EVF MODE | 105 |
| ACOUSTIC SIGNALS | 86 | PERSONALIZED LENS SETTINGS | 106 |
| ELECTRONIC SHUTTER SOUND | 86 | EV INCREMENT | 106 |
| AUTOFOCUS CONFIRMATION | 86 | AUXILIARY DISPLAYS | 107 |
| SILENT PHOTOGRAPHY | 86 | INFO PROFILES | 107 |
| STILL IMAGE SETTINGS | 88 | CHANGING THE INFO PROFILES | 108 |
| SENSOR FORMAT | 88 | DEACTIVATING INDIVIDUAL INFO PROFILES | 108 |
| FILE FORMAT | 89 | CUSTOMIZING THE INFO PROFILES | 109 |
| ASPECT RATIO | 90 | SHOW AVAILABLE | 109 |
| IMAGE PROPERTIES | 90 | INFO BARS | 109 |
| LEICA LOOKS | 90 | GRID LINES | 110 |
| CUSTOMIZING LEICA LOOKS | 90 | CLIPPING | 110 |
| LOOKS CONFIGURATION FRAME | 90 | FOCUS PEAKING | 111 |
| DOWNLOADING LEICA LOOKS | 91 | LEVEL GAUGE | 112 |
| RESETTING LEICA LOOKS | 91 | HISTOGRAM | 113 |
| AUTOMATIC OPTIMIZATION | 92 | TEMPORARY ACTIVATION/DEACTIVATION OF INDIVIDUAL FUNCTIONS | 114 |
| NOISE REDUCTION | 92 | ENHANCED LIVE VIEW | 114 |
| NOISE REDUCTION FUNCTION FOR LONG-TERM EXPOSURE | 92 | MF ASSIST FUNCTIONS | 115 |
| NOISE REDUCTION IN JPG IMAGES | 93 | AF ASSIST LAMP | 115 |
| | | ACOUSTIC AF CONFIRMATION | 115 |

| | |
|--|------------|
| PHOTOGRAPHY | 116 |
| DRIVE MODE | 116 |
| FOCUSING | 117 |
| AF PHOTOGRAPHY | 117 |
| MF PHOTOGRAPHY | 117 |
| AUTOFOCUS MODES | 117 |
| INTELLIGENT AF (IAF) | 117 |
| AFs (single) | 117 |
| AFc (continuous) | 117 |
| AUTOFOCUS METERING METHODS | 118 |
| ZONE/MULTI-FIELD METERING | 118 |
| FIELD/SPOT METERING | 119 |
| TRACKING | 119 |
| AUTOMATIC SUBJECT RECOGNITION | 120 |
| AF MODE / AF DETECTION COMBINATION | 121 |
| AF FRAME IN TRACKING WITH ACTIVATED AF DETECTION | 122 |
| AF FRAME IN TRACKING WITHOUT AF DETECTION | 122 |
| AF SETTINGS | 123 |
| AF PROFILES | 123 |
| PRE FOCUS | 125 |
| FOCUS LIMIT | 125 |
| AF QUICK SETTING | 126 |
| ACCESSING AF QUICK SETTING | 126 |
| ADJUSTING THE AF FRAME SIZE | 126 |
| CHANGING THE AF METERING METHOD | 126 |
| MF ASSIST FUNCTIONS | 127 |
| ENLARGEMENT IN AF MODE | 127 |
| AF ASSIST LAMP | 128 |
| ACOUSTIC AF CONFIRMATION | 128 |
| SHIFTING THE AF FRAME | 128 |
| MANUAL FOCUSING (MF) | 129 |
| MF ASSIST FUNCTIONS | 129 |
| FOCUS PEAKING | 129 |
| ENLARGEMENT IN MF MODE | 130 |
| DISTANCE DISPLAY | 131 |
| USING AUTOFOCUS IN MF MODE | 132 |
| ISO SENSITIVITY | 132 |
| FIXED ISO VALUES | 133 |
| AUTOMATIC SETTING | 134 |
| LIMITING SETTING RANGES | 134 |
| DYNAMIC ISO SETTING | 135 |
| FLOATING ISO | 136 |
| WHITE BALANCE | 136 |
| AUTOMATIC CONTROL/FIXED SETTINGS | 137 |
| MANUAL SETTING VIA METERING | 137 |
| GRAY CARD (PIPETTE) | 138 |
| GRAY CARD | 138 |
| DIRECT SETTING OF THE COLOR TEMPERATURE | 139 |
| EXPOSURE | 139 |
| SHUTTER TYPE | 140 |
| USE | 141 |
| EXPOSURE METERING METHODS | 141 |
| EXPOSURE MODES | 143 |
| SELECTING A MODE | 143 |
| FULLY AUTOMATIC EXPOSURE SETTING – P | 145 |
| PROGRAM AE MODE – P | 145 |
| CHANGING THE PRESET SHUTTER SPEED AND APERTURE COMBINATIONS (SHIFT) | 145 |
| SEMI-AUTOMATIC EXPOSURE SETTING – A/S | 146 |
| APERTURE-PRIORITY MODE- A | 146 |
| SHUTTER-PRIORITY MODE – S | 146 |
| MANUAL EXPOSURE SETTING – M | 147 |
| LONG-TERM EXPOSURE | 148 |
| FIXED SHUTTER SPEEDS | 148 |
| B FUNCTION | 148 |
| NOISE REDUCTION | 149 |
| EXPOSURE CONTROL | 150 |
| EXPOSURE PREVIEW | 150 |
| EXPOSURE LOCK | 151 |
| EXPOSURE COMPENSATION | 153 |
| DEPTH OF FIELD CHECK | 154 |
| SHOOTING MODES | 155 |
| CONTINUOUS SHOOTING | 155 |
| INTERVAL SHOOTING | 156 |
| EXPOSURE BRACKETING | 158 |
| MULTISHOT | 159 |
| FINE TUNING | 160 |
| SELF-TIMER | 160 |
| SPECIAL SHOOTING MODES | 161 |
| PERSPECTIVE CONTROL | 161 |
| ACTIVE PERSPECTIVE CONTROL | 162 |
| DETECTED PERSPECTIVE IN LIVE VIEW MODE | 162 |

| | | | |
|---|------------|---------------------------------------|------------|
| CORRECTED PERSPECTIVE IN REVIEW MODE..... | 162 | PREVIEW OF LATEST IMAGE | 189 |
| JPG FORMAT IMAGES..... | 163 | VIDEO SETTINGS | 190 |
| DNG FORMAT IMAGES..... | 163 | VIDEO PROFILES | 190 |
| PERSPECTIVE CONTROL IN ADOBE LIGHTROOM® AND ADOBE PHOTOSHOP® | 163 | SETTING THE VIDEO FORMAT..... | 190 |
| IMAGE OVERLAY..... | 164 | SENSOR FORMAT | 191 |
| FLASH PHOTOGRAPHY..... | 166 | FILE FORMAT..... | 191 |
| COMPATIBLE FLASH UNITS..... | 166 | VIDEO GAMMA..... | 192 |
| FLASH EXPOSURE METERING (TTL METERING)..... | 167 | DYNAMIC RANGE BOOST..... | 192 |
| SETTINGS ON THE FLASH UNIT..... | 168 | PROXY RECORDING | 193 |
| FLASH MODES..... | 168 | LEICA LOOKS | 193 |
| AUTOMATIC FLASH ACTIVATION | 168 | CUSTOMIZING LEICA LOOKS..... | 194 |
| MANUAL FLASH ACTIVATION..... | 168 | DOWNLOADING LEICA LOOKS..... | 194 |
| AUTOMATIC FLASH ACTIVATION AT SLOWER SHUTTER SPEEDS (LONG-TERM SYNCHRONIZATION)..... | 169 | RESETTING LEICA LOOKS..... | 194 |
| FLASH CONTROL..... | 169 | AUDIO SETTINGS | 195 |
| SYNC POINT..... | 169 | MICROPHONE | 195 |
| FLASH RANGE..... | 170 | WIND NOISE REDUCTION | 196 |
| FLASH EXPOSURE COMPENSATION | 171 | TIMECODE | 196 |
| REVIEW MODE | 174 | TIMECODE MODE | 197 |
| CONTROL ELEMENTS IN REVIEW MODE | 174 | START TIME..... | 197 |
| DIRECT ACCESS IN REVIEW MODE | 175 | TC SYNCHRONIZATION | 198 |
| CONTROL ELEMENTS ON THE LCD PANEL | 175 | HLG SETTINGS | 198 |
| STARTING/EXITING REVIEW MODE | 176 | L-LOG SETTINGS..... | 199 |
| SELECTING/SCROLLING THROUGH IMAGES | 177 | SETUP/MANAGEMENT OF LUT PROFILES..... | 199 |
| STORAGE LOCATIONS..... | 178 | USING LUT PROFILES..... | 201 |
| INFO DISPLAYS IN REVIEW MODE | 179 | AUTOMATIC OPTIMIZATION | 202 |
| PICTURE SERIES REVIEW | 180 | VIDEO STABILIZATION..... | 202 |
| PAUSE PLAYBACK..... | 180 | DARK AREA OPTIMIZATION (IDR)..... | 203 |
| RESUMING PLAYBACK..... | 180 | DYNAMIC RANGE..... | 203 |
| SAVE AS A VIDEO | 181 | iDR FUNCTION | 203 |
| CROPPED SECTION ZOOM..... | 182 | DATA MANAGEMENT..... | 204 |
| DISPLAYING MULTIPLE IMAGES AT ONCE..... | 183 | SEGMENTED RECORDING..... | 204 |
| TAGGING/RATING OF IMAGES..... | 185 | FORMATTING A MEMORY CARD | 205 |
| DELETING IMAGES..... | 185 | EXTERNAL DATA MEDIUM | 206 |
| DELETING INDIVIDUAL IMAGES | 186 | DATA STRUCTURE | 206 |
| DELETING MULTIPLE IMAGES | 187 | EDIT FILE NAMES | 207 |
| DELETING ALL UNRATED IMAGES..... | 188 | CREATING A NEW FOLDER..... | 208 |
| DELETING PICTURE SERIES..... | 188 | LOGGING THE SHOOTING LOCATION..... | 208 |
| | | DATA TRANSFER | 209 |

| | | | |
|---|------------|--|------------|
| PRACTICAL DEFAULT SETTINGS | 210 | START/END VIDEO RECORDING | 232 |
| TOUCH AF | 210 | DISPLAY AND OPERATION VIA USB-PTP USING EXTERNAL ACCESSORY (LIKE GIMBALS) | 232 |
| TOUCH AF + SHUTTER BUTTON | 211 | FOCUSING | 233 |
| TOUCH AF IN EVF MODE | 211 | AUTOFOCUS MODES | 233 |
| PERSONALIZED LENS SETTINGS | 212 | CONTROLLING THE AUTOFOCUS | 234 |
| EV INCREMENT | 212 | TOUCH AF | 234 |
| AUDIO OUTPUT | 213 | SUPPRESSING CONTINUOUS FOCUSING | 234 |
| SETTING THE OUTPUT LEVEL | 213 | AUTOFOCUS METERING METHODS | 234 |
| HDMI OUTPUT WITH/WITHOUT SOUND | 213 | ZONE/MULTI-FIELD METERING | 235 |
| AUXILIARY DISPLAYS | 214 | FIELD/SPOT METERING | 235 |
| INFO PROFILES | 214 | TRACKING | 236 |
| CHANGING THE INFO PROFILES | 215 | AF DETECTION | |
| DEACTIVATING INDIVIDUAL INFO PROFILES | 215 | AUTOMATIC SUBJECT RECOGNITION | 237 |
| CUSTOMIZING THE INFO PROFILES | 216 | AF MODE / AF DETECTION COMBINATION | 238 |
| SHOW AVAILABLE | 216 | AF SETTINGS | 238 |
| INFO BARS | 216 | FOCUS LIMIT | 239 |
| GRID LINES | 217 | AF QUICK SETTING | 239 |
| ZEBRA | 217 | ADJUSTING THE AF FRAME SIZE | 240 |
| FOCUS PEAKING | 218 | CHANGING THE AF METERING METHOD | 240 |
| FALSE COLOR | 219 | MF ASSIST FUNCTIONS | 240 |
| HIGHLIGHT COLOR | 219 | ENLARGEMENT IN AF MODE | 240 |
| LEVEL GAUGE | 220 | SHIFTING THE AF FRAME | 242 |
| HISTOGRAM | 221 | MANUAL FOCUSING (MF) | 242 |
| WAVEFORM MONITOR (WFM) | 222 | MF ASSIST FUNCTIONS | 243 |
| ADJUSTING VISUALIZATION | 223 | FOLLOW FOCUS | 245 |
| ASPECT RATIO DISPLAY | 224 | FUNCTION BEHAVIOR | 246 |
| FRAMELINE | 224 | FOLLOW FOCUS MENU | 246 |
| VIDEO ASSIST FUNCTIONS | 225 | PREPARATION | 247 |
| REFERENCE VALUES | 225 | CONFIGURING A FOCUS POSITION | 247 |
| COLOR BAR | 225 | CHANGING THE FOCUS POSITION | 248 |
| TEST SOUND | 226 | USE | 249 |
| USE | 226 | ACCESS AS NEEDED | 249 |
| REC FRAME | 227 | AUTOMATIC SEQUENCE | 250 |
| MF ASSIST FUNCTIONS | 228 | OTHER SETTINGS | 251 |
| AF ASSIST LAMP | 228 | SPEED | 251 |
| RECORDING VIDEO | 230 | SUBSEQUENT FOCUS MODE | 251 |
| VIDEO MODE AND CINE MODE | 230 | ISO SENSITIVITY | 252 |
| START/EXIT VIDEO MODE | 231 | FIXED ISO VALUES | 252 |
| | | AUTOMATIC SETTING | 253 |
| | | DYNAMIC ISO SETTING | 255 |

| | | | |
|---|------------|--|------------|
| FLOATING ISO | 255 | MIRROR LCD PANEL IMAGE VIA HDMI TO EXTERNAL SCREEN | 284 |
| ASA SENSITIVITY | 256 | OTHER FUNCTIONS | 286 |
| WHITE BALANCE | 256 | RESETTING THE CAMERA TO FACTORY SETTINGS .. | 286 |
| AUTOMATIC CONTROL/FIXED SETTINGS | 257 | FIRMWARE UPDATES | 287 |
| MANUAL SETTING VIA METERING | 257 | EXECUTING A FIRMWARE UPDATE | 288 |
| GRAY CARD (PIPETTE) | 258 | CAMERA-TO-CLOUD – FRAME.IO | 290 |
| GRAY CARD | 258 | LEICA FOTOS | 292 |
| DIRECT SETTING OF THE COLOR TEMPERATURE | 259 | SELECTING A WI-FI BAND | 292 |
| EXPOSURE | 259 | CONNECTION - iOS | 293 |
| EXPOSURE MODES | 261 | FIRST-TIME CONNECTION TO A MOBILE DEVICE | 293 |
| FULLY AUTOMATIC EXPOSURE SETTING – P | 263 | CONNECTING WITH PAIRED DEVICES | 295 |
| SEMI-AUTOMATIC EXPOSURE SETTING – A/S | 263 | CONNECTION - ANDROID | 296 |
| MANUAL EXPOSURE SETTING – M | 264 | FIRST-TIME CONNECTION TO A MOBILE DEVICE | 296 |
| EXPOSURE COMPENSATION | 264 | CONNECTING WITH PAIRED DEVICES | 297 |
| FULLY AUTOMATIC EXPOSURE SETTING – P | 265 | CONNECTIVITY MODES | 298 |
| SEMI-AUTOMATIC EXPOSURE SETTING – A/S | 266 | PERFORMANCE MODE | 299 |
| MANUAL EXPOSURE SETTING – M | 266 | ECO MODE | 299 |
| EXPOSURE COMPENSATION | 267 | AIRPLANE MODE | 299 |
| COMPENSATION PROFILES FOR ANARMOPHIC LENSES | 267 | EXECUTING A FIRMWARE UPDATE | 299 |
| PLAYBACK MODE | 268 | REMOTE CAMERA CONTROL | 300 |
| CONTROL ELEMENTS IN PLAYBACK MODE | 268 | CARE/STORAGE | 302 |
| DIRECT ACCESS IN PLAYBACK MODE | 269 | AUTOMATIC SENSOR CLEANING | 303 |
| CONTROL ELEMENTS ON THE LCD PANEL | 269 | PIXEL MAPPING | 303 |
| STARTING/EXITING PLAYBACK MODE | 270 | FAQ | 304 |
| SELECTING/SCROLLING THROUGH RECORDINGS .. | 271 | MENU OVERVIEW | 312 |
| STORAGE LOCATIONS | 272 | TECHNICAL DATA | 320 |
| INFO DISPLAYS IN PLAYBACK MODE | 273 | LEICA CUSTOMER CARE | 326 |
| DISPLAYING MULTIPLE IMAGES AT ONCE | 274 | LEICA AKADEMIE | 327 |
| TAGGING/RATING OF RECORDINGS | 275 | | |
| DELETING RECORDINGS | 276 | | |
| DELETING INDIVIDUAL RECORDINGS | 276 | | |
| DELETING MULTIPLE RECORDINGS | 277 | | |
| DELETING ALL UNRATED RECORDINGS | 278 | | |
| VIDEO PLAYBACK | 279 | | |
| VIDEO EDITING | 282 | | |
| HDMI SETTINGS | 283 | | |
| HDMI RESOLUTION | 284 | | |

PART DESIGNATIONS

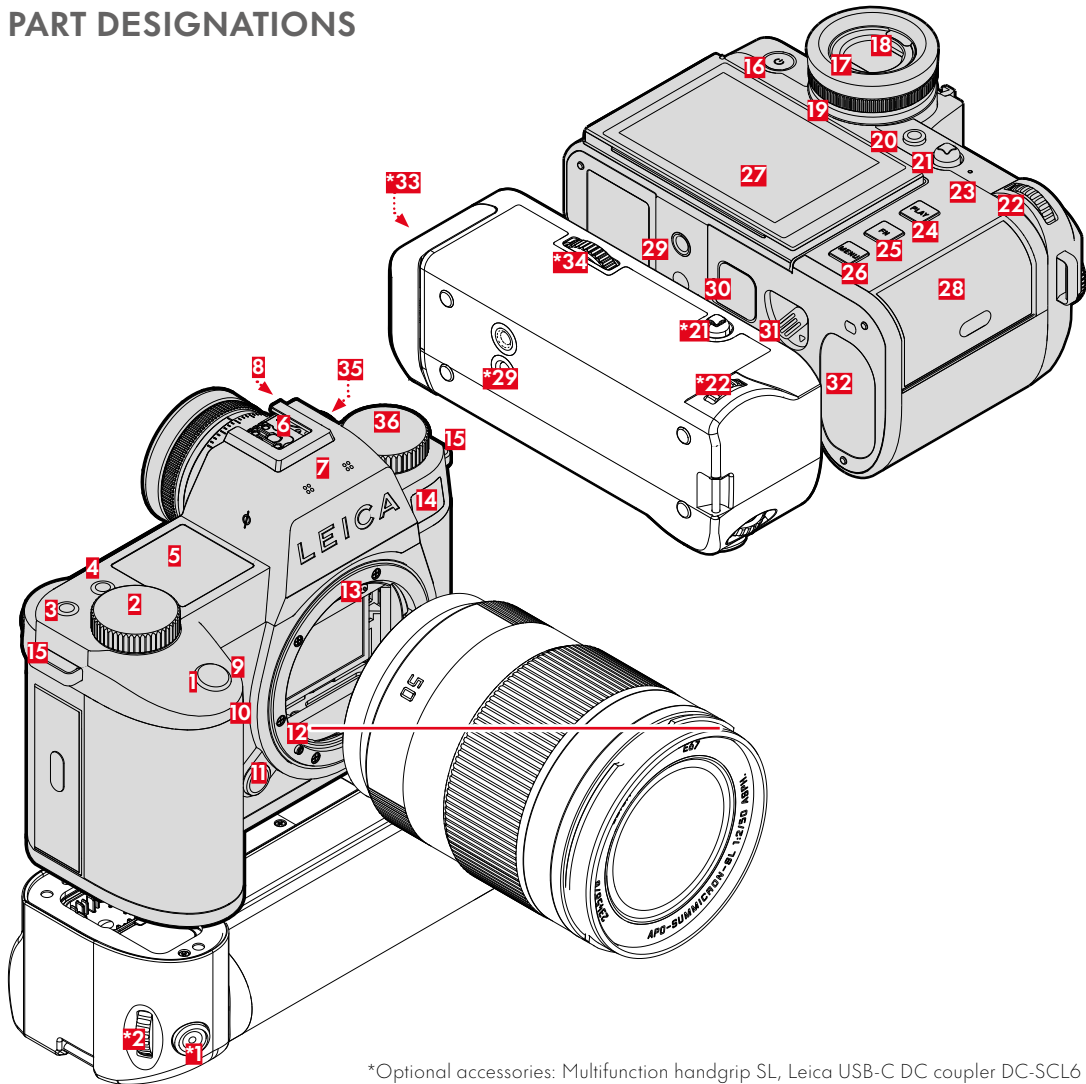

*Optional accessories: Multifunction handgrip SL, Leica USB-C DC coupler DC-SCL6

LEICA SL3-P

- 1** Shutter button
- 2** Right dial
- 3** Function button
- 4** Function button
- 5** Top display
- 6** Accessory shoe
- 7** Microphone
- 8** Speaker
- 9** Function button
- 10** Function button
- 11** Lens release button
- 12** Leica L bayonet
- 13** Contact strip
- 14** Self-timer LED / AF Assist Lamp / Sensor for exposure metering
- 15** Strap lugs
- 16** Main switch
- 17** Viewfinder eyepiece
- 18** Eye sensor
- 19** Diopter setting ring
- 20** **FN** button**
- 21** Joystick
- 22** Thumbwheel
- 23** Status LED
- 24** **PLAY** button
- 25** **FN** button**
- 26** **MENU** button
- 27** LCD panel
- 28** Memory card slot
- 29** Tripod thread

- 30** Contact for multifunction handgrip
- 31** Battery release lever
- 32** Battery compartment
- *33** Handgrip-integrated battery compartment
- *34** Handgrip lock
- 35** Timecode connection
- 36** Left dial

MULTIFUNCTION HANDGRIP HG-SCL7

- *1** Shutter button
- *2** Right dial
- *21** Joystick
- *22** Thumbwheel
- *29** Tripod thread
- *33** Handgrip-integrated battery compartment
- *34** Handgrip lock

CONNECTOR BLOCK

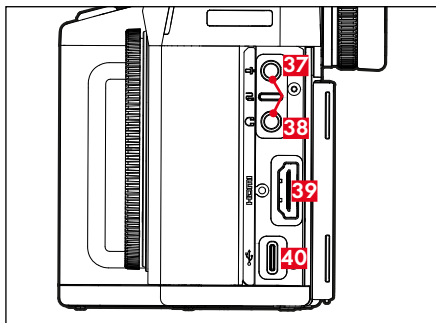

- 37** Microphone
- 38** Headphones / remote shutter release
- 39** HDMI
- 40** USB-C

USB-C DC COUPLER DC-SCL6

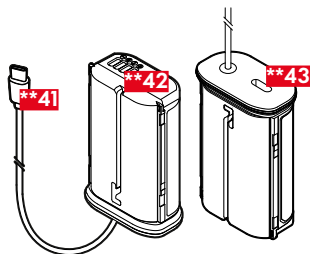

- **41** USB-C cable socket (microphone or remote shutter release)
- **42** Contacts
- **43** USB-C cable socket (transport protection)

* Not included in the delivery package. Representative image.
Technical designs may vary depending on included features.

LENS*

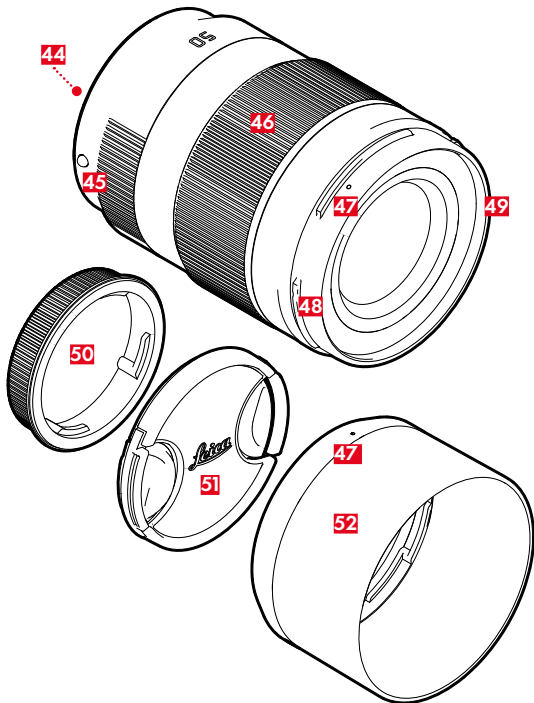

- 44 Contact strip
- 45 Alignment points for lens replacement
- 46 Focus ring
poss. zoom ring
- 47 Alignment point for lens hood mounting
- 48 Male bayonet for lens hood
- 49 Internal thread for filters
- 50 Bayonet cover
- 51 Lens cap
- 52 Lens hood

DISPLAYS

The images displayed on the LCD panel and in the viewfinder are identical.

PHOTO

CONTROL CENTER

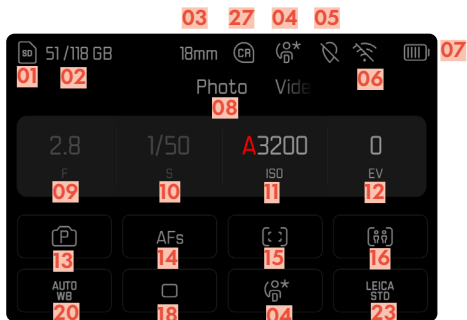

SHOOTING IN PORTRAIT FORMAT

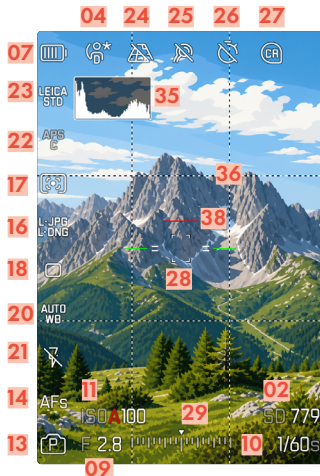

IN SHOOTING MODE

All displays/values refer to the actual settings.

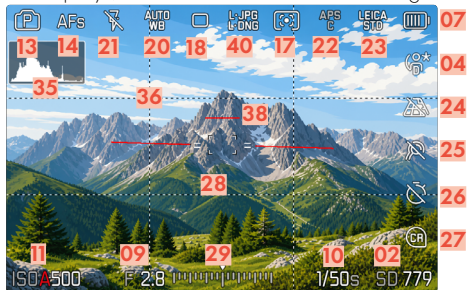

IN REVIEW MODE

All displays/values refer to the displayed image.



01 Memory card used

- 02 Remaining storage capacity
- 03 Focal length
- 04 User profile
- 05 Geotagging
Automatic storage of the shooting location (Exif data)
- 06 Wi-Fi/Bluetooth® (Leica FOTOS)
- 07 Battery capacity
- 08 Menu section PHOTO
- 09 Aperture value
- 10 Shutter speed
- 11 ISO Sensitivity
- 12 Exposure compensation value
- 13 Exposure mode
- 14 Focus mode
- 15 Autofocus metering method
- 16 AF Detection
- 17 Exposure metering method
- 18 Shooting mode (Drive Mode)
- 19 Leica FOTOS
- 20 White balance mode
- 21 Flash mode/flash exposure compensation
(in photo mode only)
- 22 Sensor format
- 23 Color rendering (Leica Looks)
- 24 Perspective Control
- 25 Focus peaking
(identification of in sharp edges in the object)
- 26 Self-timer
- 27 Leica Content Credentials
- 28 AF Field
- 29 Exposure compensation scale
- 30 Filter
- 31 Icon for marked picture
- 32 Delete
- 33 File number of the image shown
- 34 Date and time of shot
- 35 Histogram
- 36 Grid lines
- 37 Clipping identification of overexposed subject elements
- 38 Level gauge
- 39  Display of cropped section size and position
(only visible for enlarged sections)
- 40 File format

VIDEO/CINE

CONTROL CENTER

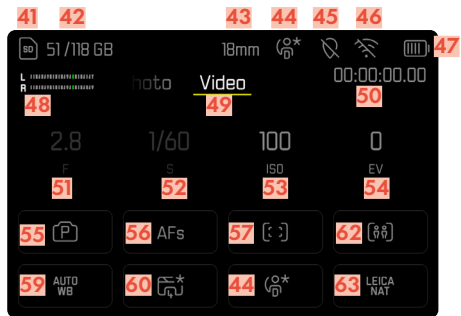

IN RECORDING MODE

All displays/values refer to the actual settings.



IN PLAYBACK MODE

All displays/values refer to the displayed image.

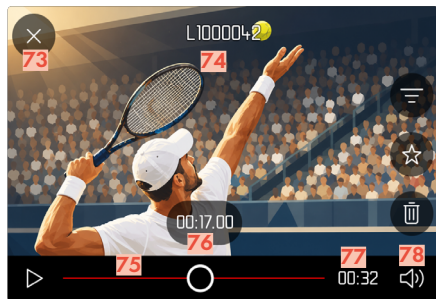

- 41 Memory card used
- 42 Remaining storage capacity
- 43 Focal length
- 44 User profile
- 45 Geotagging
Automatic storage of the shooting location (Exif data)
- 46 Wi-Fi/Bluetooth® (Leica FOTOS)
- 47 Battery capacity
- 48 Microphone recording level
- 49 Menu sections VIDEO
- 50 Timecode counter
- 51 Aperture value
- 52 Shutter speed
- 53 ISO Sensitivity
- 54 Exposure compensation value
- 55 Exposure mode
- 56 Focus mode
- 57 Autofocus metering method
- 58 Exposure metering method
- 59 White balance mode
- 60 Video profile
- 61 Microphone sensitivity (Microphone Gain)
- 62 AF Detection
- 63 Color rendering (Leica Looks)
- 64 Indicates for video recording in progress
- 65 Exposure compensation scale
- 66 File format
- 67 Resolution
- 68 Frame rate
- 69 Start playback
- 70 Filter
- 71 Icon for marked video recording
- 72 Delete
- 73 Exiting video playback
- 74 File name of the displayed video recording
- 75 Playback status bar
- 76 Current playback time
- 77 Length of video recording
- 78 Volume bar

DISPLAYS IN THE TOP DISPLAY

Home screen



DEFAULT VIEW

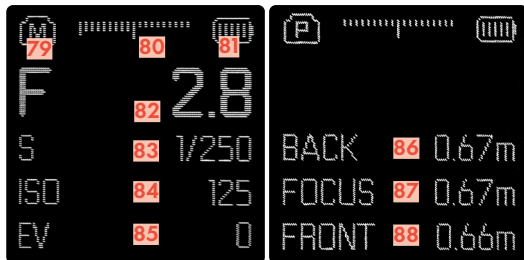

- 78 Camera name
- 79 Operating mode
- 80 Light balance
- 81 Battery capacity
- 82 Aperture value
- 83 Shutter speed
(Cine: shutter angle)
- 84 ISO Sensitivity
(Cine: ASA indication)
- 85 Exposure compensation value
- 86 End of focus range
- 87 Current focus range
- 88 Start of focus range

CHARGE STATUS INDICATOR ON THE LCD PANEL

The charge level of the rechargeable battery is displayed in the Control Center and in the header line at the top right.

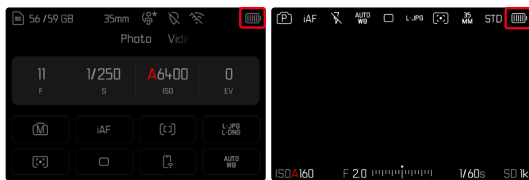

| Display | Charge status |
|---------|---|
| | Approx. 80 – 100% |
| | Approx. 60 – 79% |
| | Approx. 40 – 59% |
| | Approx. 20 – 39% |
| | Approx. 1 – 19% |
| | Approx. 0% The battery needs charging or replacing |

PREPARATION

ATTACHING THE CARRY STRAP

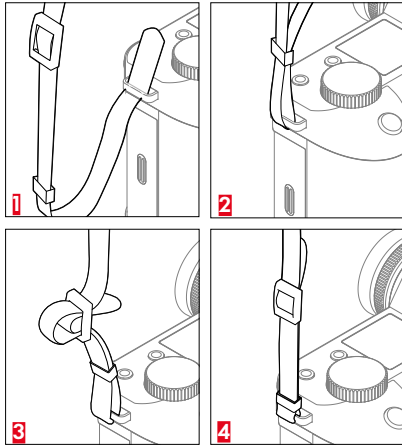

Attention

- Once you have attached the carry strap, please make sure that the clips are mounted correctly to prevent the camera from falling.

PREPARING THE CHARGER (optional accessory)

Use the mains cable with the matching regional plug to connect the charger to mains electricity.

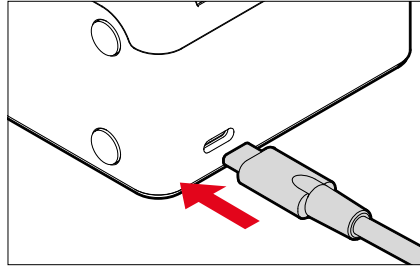

Note

- The charger will automatically adapt to local mains voltage.

CHARGING THE BATTERY

The camera is powered by a lithium-ion battery.

INSERTING THE BATTERY IN THE CHARGER

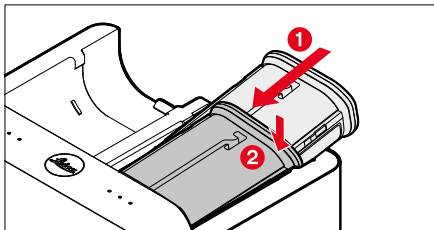

- Slide the battery into the charger with the groove facing up until the contacts meet
- Press down on the battery until you can hear and feel it clicking into place
- Ensure that the battery is fully inserted into the charger

REMOVING THE BATTERY FROM THE CHARGER

- Tilt the battery up and lift it out at an angle

CHARGE STATUS INDICATORS ON THE CHARGER

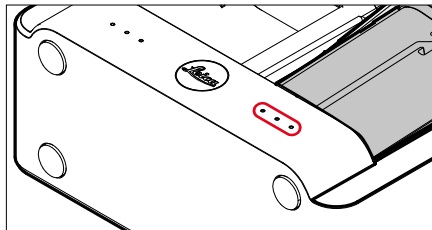

The status LED indicates a correct charging process.

| Display | Charge status | Charge time* |
|---------|---------------------|---------------|
| • | Battery is charging | |
| •• | 80% | Approx. 2 h |
| ••• | 100% | Approx. 3.5 h |

Disconnect the charger from mains electricity when the charging process is complete. There is no risk of over-charging.

* for a completely discharged battery

CHARGING VIA USB

The rechargeable battery in the camera can be automatically charged when the camera is connected to a computer or another suitable power source via USB cable.

Notes

- The SL3-P can be charged while it is switched on. This requires a USB PD-capable power supply unit with an output of min. 9 V/3 A (27 W). Where a power supply unit with an output of less than 27 W is used, the camera can only be charged while it is switched off.
- The rechargeable battery in the optional Multifunction Handgrip (HG-SCL7) can also be charged via the camera and power supply unit.
- The charging will start automatically.
- For safety reasons, the battery is only minimally charged on delivery. The battery must be activated with an initial charge before first use.



INSERTING/REMOVING THE BATTERY

- Ensure that the camera is switched OFF (see p. 52)

INSERTION

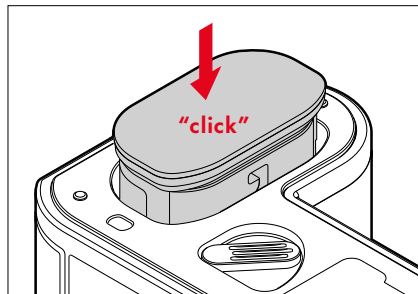

- Insert the battery into the slot with the groove pointing towards the LCD panel and gently push until you hear and feel it clicking into place

REMOVAL

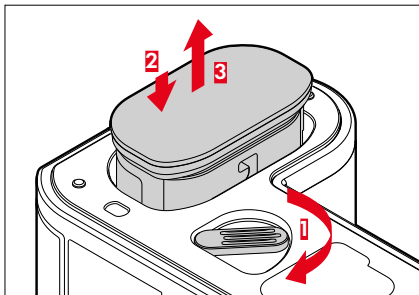

- Turn the battery release lever
 - Battery is pushing out slightly.
- Press down on the battery lightly
 - The battery unlocks and pushes out fully.
- Remove the battery

Important

- Removing the battery while the camera is switched on may result in the loss of custom settings, the loss of saved images, or damage to the memory card. In extreme cases, the internal memory may become damaged, and the camera may no longer start up.

INSERTING/REMOVING THE MEMORY CARD

Leica SL3-P offers slots for two memory cards. There are various options for use, see p. 98.

The camera will save exposures to an SD (Secure Digital), SDHC (Secure Digital High Capacity), or SDXC (Secure Digital eXtended Capacity) card, and to a Cfexpress (Compactflash express) Type B.

Notes

- SD/SDHC/SDXC memory cards are available from various manufacturers in various sizes and with different read/write speeds. Memory cards with high storage capacities and high read/write speeds offer quick storage and rendering.
- The memory card may not be supported (capacity) or will have to be formatted in the camera before first use (see p. 98). The camera will in that case display a relevant message. Please see the section “Technical Data” for information about supported cards.
- Check the memory card for correct alignment if you are having difficulties inserting it into the camera.
- Video shootings require a high write speed.

OPENING THE COVER OVER THE MEMORY CARD SLOT

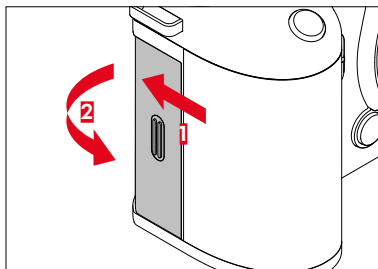

- Slide the cover as shown in the illustration until you hear a click
 - The cover lifts automatically.

CLOSING THE COVER OVER THE MEMORY CARD SLOT

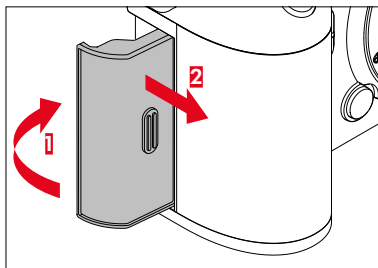

- Close and hold down the cover
- Slide the cover as shown in the illustration until it audibly clicks into place

INSERTION

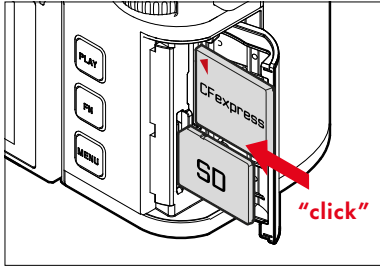

- Push the memory card into the slot until you hear and feel it clicking into place
 - The beveled corner of the SD card must be at the top left.
 - The ◀ marking on the CFe card must point towards the back when inserting the card.

REMOVAL

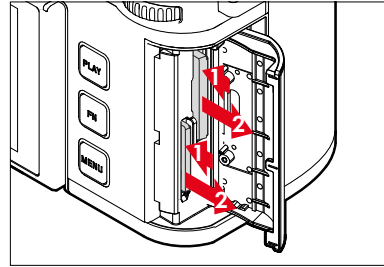

- Push down on the card until you hear a click
 - The card pushes out slightly.
- Remove the memory card

LENSES

COMPATIBLE LENSES

Sophisticated optical systems guarantee the excellent imaging performance of the SL lenses. In the design phase for the optics, a homogeneous performance across all focal lengths, aperture and focus settings is a high priority. That is how SL lenses can be used for optimally creative results in any situation.

Furthermore, Leica M-, Leica S- and R-lenses can be used in conjunction with suitable Leica lens adapters.

L-MOUNT LENSES

In addition to Leica SL lenses, the Leica SL3-P can also accommodate Leica TL lenses with full functionality via the L bayonet. The camera will automatically switch to the APS-C format when a TL lens is attached. A variety of compatible lenses from manufacturers of the L-Mount Alliance are also available.

EXPOSURE METERING AND EXPOSURE CONTROL USING VARIO LENSES

Some Leica TL, SL Vario, and L-mount lenses have a variable light intensity, which means that the effective lens aperture varies depends on the configured focal length. Make sure to set the desired focal length before storing the meter value or changing the shutter speed/ aperture combination to prevent incorrect exposure. Please read the sections on "Exposure" starting on page 141 for more information. Make sure that the aperture setting on the flash unit matches the camera aperture if you are using a non-system compatible flash unit.

LEICA M AND R LENSES

Leica M and R lenses can be attached via Leica M or R L adapters. There are lens profiles stored in the camera, which allow the following functions:

- The flash exposure and flash reflector controls utilize the stored lens data (see “Compatible flash units”).
- As a rule, the correct focal length for lenses that are not detected automatically should always be set manually.
- The lens data is furthermore written to the Exif data of the recordings, provided the lens is relevantly encoded. The focal length of the lens is additionally displayed when rendering the extended image data.

The camera will automatically select the appropriate lens type settings if the Leica M lens used comes with 6-bit encoding, or the Leica R lens has an ROM contact strip. You will have to enter the lens type manually if the lenses do not have that feature.

Using automatic detection

- Select **Camera Settings** in the main menu
- Select **Lens Profiles**
- Activate automatic lens detection (**Auto**) or deactivate the feature (**Off**)

Setting the lens type manually

- Select **Camera Settings** in the main menu
- Select **Lens Profiles**
- Select **M-Lenses** or **R-Lenses**

Sorting the lens type lists

- Select **Camera Settings** in the main menu
- Select **Lens Profiles**
- Select **M-Lenses** or **R-Lenses**
- Select **Edit List of M-Lenses** or **Edit List of R-Lenses**
- Activate (**On**) or deactivate (**Off**) the lens types you will be using

COMPENSATION PROFILES FOR ANAMORPHIC LENSES

Anamorphic lenses capture a particularly wide field of view by horizontally compressing the subject on the sensor (squeeze). This process facilitates the classic cinema aspect ratio and creates the characteristic cinematic look.

The **Lens Profiles** correct this image compression directly in-camera during playback, so that the preview image in the viewfinder or display is shown in the correct aspect ratio. This allows the subject to be assessed precisely during shooting – perfect for professional film productions using anamorphic optics.

- Select **Camera Settings** in the main menu
- Select **Lens Profiles**
- Select the desired setting
(**1.25**, **1.3**, **1.33**, **1.5**, **1.6**, **1.65**, **1.8**, **1.85**, **2.0**)

Notes

- This function is available only when using manual anamorphic lenses in Video mode.
- If an autofocus lens is attached, the menu option remains grayed out. Please remember to attach a manual anamorphic lens first before attempting to activate the function.

CHANGING THE LENS

Important

- Make sure to always have a lens or the camera bayonet cover attached to prevent dust or other foreign bodies penetrating the camera.
- That is why you should always replace lenses quickly and in a dust-free environment.

L-MOUNT LENSES

ATTACHING THE LENS

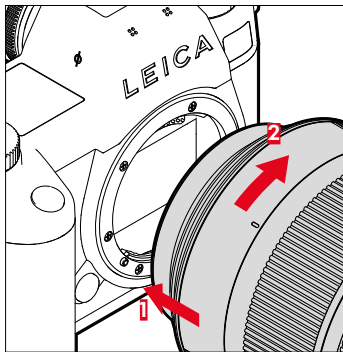

- Ensure that the camera is switched OFF (see p. 52)
- Hold the lens by the fixed ring
- Position the alignment points on the lens opposite the release button on the camera housing
- Attach the lens in this position
- Turn the lens clockwise until you hear and feel it click into place

DETACHING THE LENS

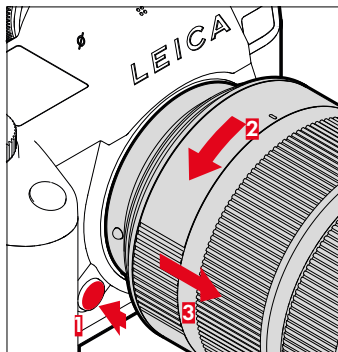

- Ensure that the camera is switched OFF
- Hold the lens by the fixed ring
- Press and hold the release button on the camera housing
- Turn the lens counter-clockwise until the alignment point is opposite the release button
- Detach the lens

OTHER LENSES (e.g. Leica M lenses)

Other lenses can be used by inserting an adapter for L bayonets (e.g. Leica-M adapter L).

ATTACHING THE ADAPTER

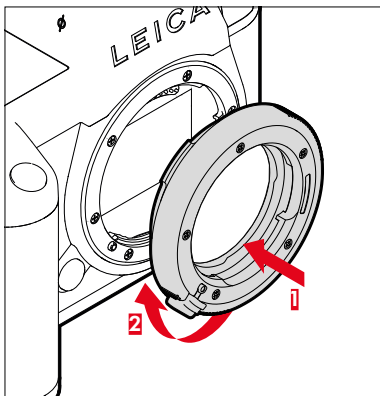

- Ensure that the camera is switched OFF (see p. 52)
- Position the alignment point on the adapter opposite the alignment point on the camera housing
- Attach the lens in this position
- Turn the adapter clockwise until you hear and feel it click into place
- Attach the lens immediately

DETACHING THE ADAPTER

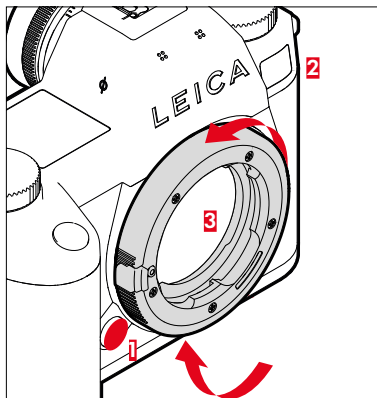

- Ensure that the camera is switched OFF
- Detach the lens
- Press and hold the release button on the camera housing
- Turn the adapter counter-clockwise until the alignment point is opposite the release button
- Detach the adapter

ATTACHING THE LENS TO THE ADAPTER

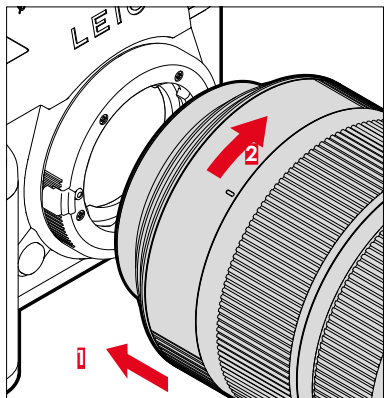

- Ensure that the camera is switched OFF (see p. 52)
- Hold the lens by the fixed ring
- Position the alignment point on the lens opposite the alignment point on the adapter
- Attach the lens in this position
- Turn the lens clockwise until you hear and feel it click into place

DETACHING THE LENS FROM THE ADAPTER

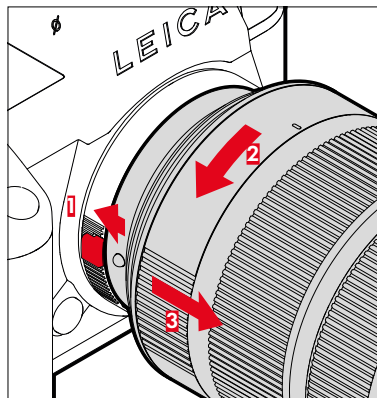

- Ensure that the camera is switched OFF
- Hold the lens by the fixed ring
- Press and hold the release button on the adapter
- Turn the lens counter-clockwise until its alignment point is opposite the release button
- Detach the lens

DIOPTER SETTINGS

The viewfinder has a diopter setting function with a range between -4 and $+2$ diopter to allow glasses wearers the use of the camera without eyeglasses (diopter compensation).

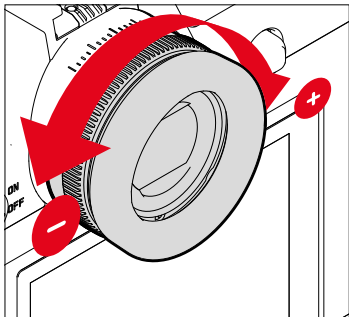

- Look through the viewfinder
- Aiming at and focusing on an object
- Turn the diopter setting ring until you see the image in the viewfinder and the displays in perfect focus

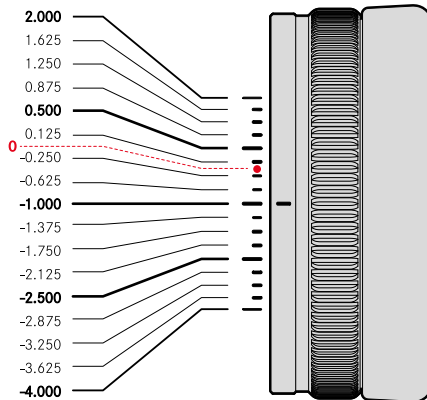

MULTIFUNCTION HANDGRIP HG-SCL7 (optional accessory)

The Multifunction Handgrip SL is an optional accessory and comes with additional operating elements positioned to specifically facilitate vertical format photography (shutter button, joystick, thumbwheel, and right dial). It ensures a secure grip for single-handed shooting. It also offers space for a second rechargeable battery.

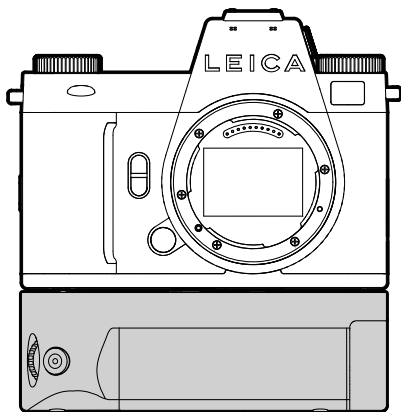

PHOTOGRAPHY WITH THE HANDGRIP

The operating elements of the handgrip are positioned in such a way as to be in easy reach when using the camera for portrait photography.

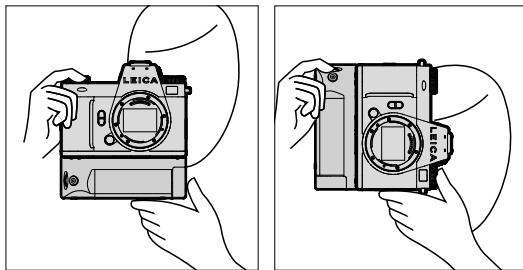

ATTACHING THE HANDGRIP

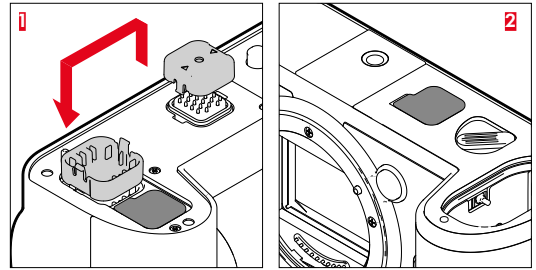
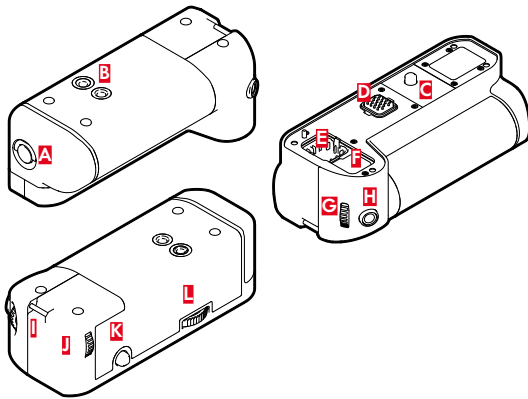

- A** Locking toggle
- B** Tripod thread
- C** Attachment screw
- D** Interface with the camera
- E** Storage compartment for the contact cover of the handgrip
- F** Storage compartment for the contact cover of the camera
- G** Right dial
- H** Shutter button
- I** Strap lug
- J** Thumbwheel
- K** Joystick
- L** Handgrip lock

- Squeeze the contact cover of the handgrip on the two sides marked with triangles and lift it off
- Store the contact cover in its designated compartment in the handgrip
- Remove the contact cover in the base of the camera housing
- Store the contact cover in its designated compartment in the handgrip

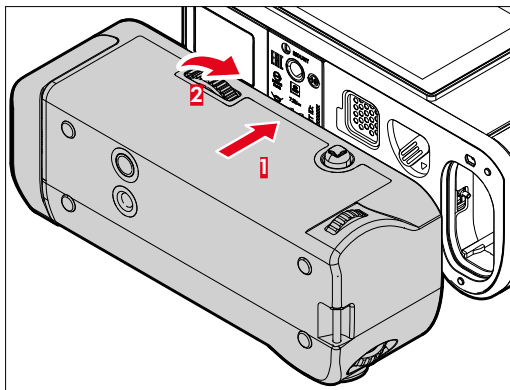

DETACHING THE HANDGRIP

- Turn the handgrip lock to the left to unlock the connection
 - Make sure to hold the camera and the handgrip securely while doing so.
- Replace both cover caps over the connections

Important

- Make sure that the contact covers are securely in place on the camera and on the handgrip whenever the handgrip is not attached to the camera. The highly sensitive contacts could otherwise easily be damaged.

- Align the handgrip with the base of the camera
 - Make sure not to damage the contacts.
- Turn the handgrip lock to the right and hand tighten

Important

- Make sure to check regularly whether the connection is still tight when using the camera with the handgrip attached and re-tighten it as needed.

MOUNTING THE WRIST LOOP/CARRY STRAP ON THE MULTIFUNCTION HANDGRIP

The high quality wrist loop is available as an optional ergonomic accessory for the handgrip to ensure more stability for the camera. The hand loop is recommended in particular for landscape photography.

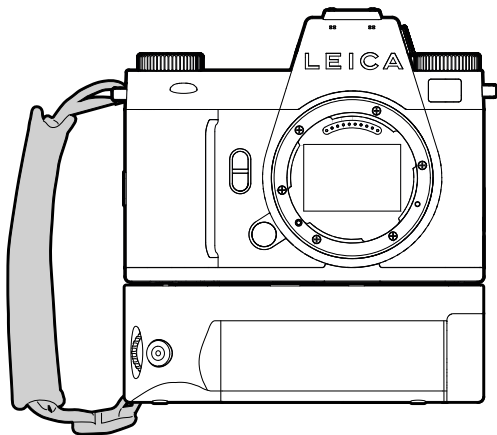

When using the handgrip for portrait photography for extended periods of time, we recommend attaching the carry strap on the strap lug of the camera on the right-hand side and on the strap lug of the handgrip. This will always maintain the camera in the correct position. See p. 32 for instructions on how to attach the carry strap.

CHANGING THE BATTERY

The multifunction handgrip offers space for a second rechargeable battery. This will significantly increase operating time.

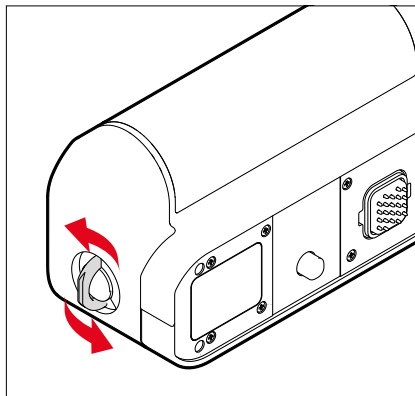

- Click up the locking toggle
- Turn the locking toggle in anti-clockwise direction
 - The battery cover lifts automatically.

REMOVING THE BATTERY

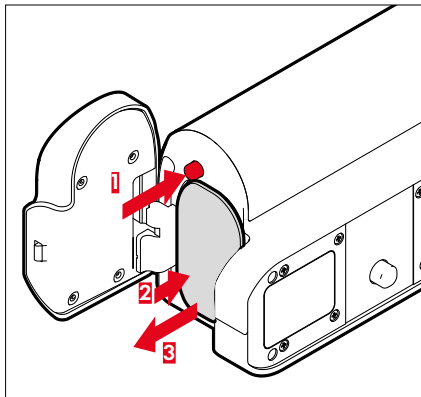

- Push down the ejector pin
 - Battery is pushing out slightly.
- Press down on the battery *lightly*
 - The battery unlocks and pushes out fully.
- Remove the battery

Notes

- The battery inside the handgrip can be recharged via USB-C.
- The battery inside the handgrip will be utilized first. Once depleted, the camera will automatically switch from the battery inside the handgrip to the battery inside the camera.
- Removing the battery while the camera is switched on may result in the loss of custom settings or damage to the memory card.

INSERTING THE BATTERY

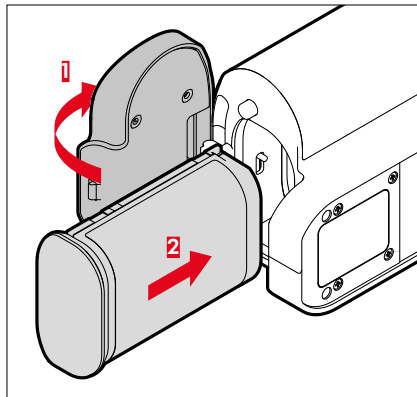

- Insert the battery into the slot with the groove pointing towards until you hear and feel it clicking into place

CLOSE THE BATTERY COMPARTMENT

- Close the cover over the battery compartment
 - It will click to signify it is locked.
- Click down the locking toggle

Note

- The camera must have a battery with at least minimal charge inserted to utilize a rechargeable battery in the handgrip.

CAMERA OPERATION

CONTROL ELEMENTS

MAIN SWITCH

The main switch switches the camera on, off, or to stand-by.

SWITCHING THE CAMERA ON/OFF

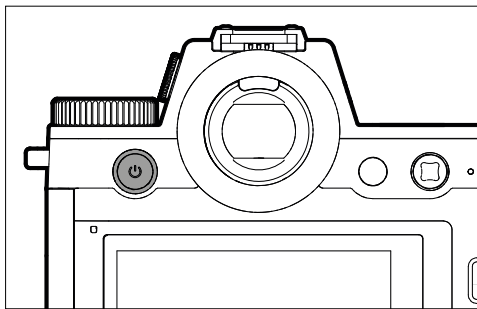

| Status | Button press | Function |
|--------------|----------------------------|---------------|
| Off | Press and release (>0.1 s) | Switching on |
| On | Press and release (>0.1 s) | Standby mode |
| On | Press and hold (>1.5 s) | Switching off |
| Standby mode | Press and hold (>1.5 s) | Switching off |
| Standby mode | Press and release (>0.1 s) | Switching on |

Notes

- Once switched on, the camera will be ready to use after approx. 1 s.
- The main switch LED lights up briefly and the displays appear in the viewfinder.
- The function **Auto Power Off** (see p. 84) deactivates the camera automatically if no operation occurs within a preset time. Use the main switch to deactivate the camera if this function is **Off** to prevent inadvertent exposures and battery discharge when the camera is not in use. The same applies for Standby mode.

MAIN SWITCH LED

The main switch LED indicates various operating states. It will light within 1 s of the main switch being pressed. The LED can be set to automatically dim depending on ambient brightness. The brightness of the LED is reduced automatically during camera operation.

Adjusting the setting

Factory setting: **Low**

- Select **Camera Settings** in the main menu
- Select **Power Saving**
- Select **Power Button LED**
- Select **Settings**
- **Low** (approx. 2% brightness)/**High** (approx. 7% brightness)/**Auto** (changes from **Low** to **High** depending on ambient brightness)

Notes

- At low battery capacity, the LED will light approx. 3 s after camera activation.
- The LED switches off automatically when the viewfinder is in use.

| Function | Behavior | Color | Notes |
|--|--|-------|---|
| Camera is OFF Camera Standby No USB charging available | Off | - | - |
| Camera is OFF Camera Standby USB charging available | Dims on and off during charging process Lights continuously when battery is fully charged | Green | The green charging LED depends on the menu setting with one exception: With the menu setting Off or Auto , the brightness setting Low should be used to signal the charging process. |
| Camera switches to Standby mode | 1x flash | White | Brightness depending on menu setting |
| Ready | Dimmed | White | |
| Problem | Dimmed | Red | - Desired function unavailable due to insufficient battery charge level - Error message in the camera menu |

SHUTTER BUTTON

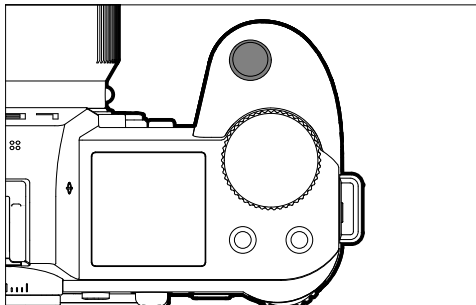

The shutter button works in two stages.

1. **Tapping** (= Pressing the shutter button to the 1st pressure point)
 - Activating the camera electronics and displays
 - Exposure lock (metering & saving):
 - AF mode: focusing (AF-Lock)
 - (semi) automatic exposure mode: exposure metering (AE-Lock)
 - Canceling a running self-timer delay time
 - Return to shooting mode
 - from review mode
 - from menu control
 - from standby mode

2. Press down fully

- Shutter release
- The data is then transferred to the memory card.
 - Starting a video shooting
 - Initiating a preset self-timer delay time
 - Starting a continuous shooting or interval shooting

Notes

- Press down the shutter button in a smooth motion until you hear the click of the shutter to prevent camera shake.
- The shutter button remains locked:
 - if the memory card inserted and/or the internal buffer memory are (temporarily) full
 - if the battery has exceeded its performance limits (capacity, temperature, age)
 - if the memory card is write-protected or damaged
 - if the sensor is too hot

LEFT DIAL

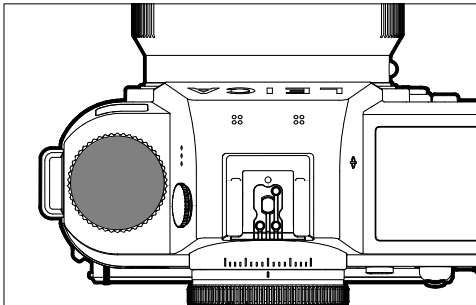

- In shooting mode: Setting ISO values

RIGHT DIAL

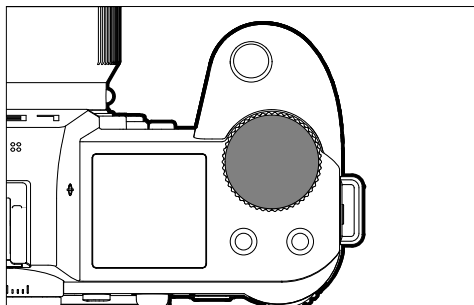

- Menu navigation
- Setting the shutter speeds
- Exposure compensation value selection
- Enlarging/reducing viewed images

THUMBWHEEL

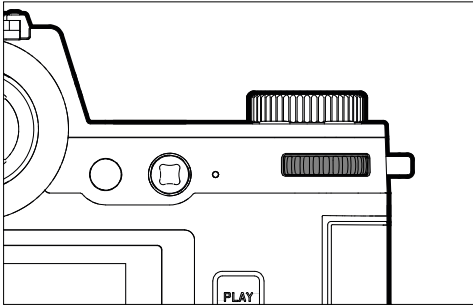

- Menu navigation
- Accessing the submenu
- Applying menu settings
- Setting selected menu items/functions
- Setting the aperture value
- Exposure compensation value selection
- Setting the program shift
- Scrolling through the gallery
- Playback of video recordings
- Confirming the prompts

JOYSTICK

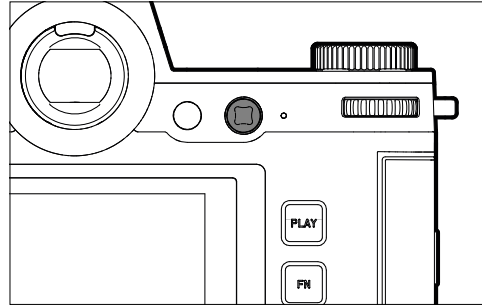

- Menu navigation
- Accessing the submenu
- Applying menu settings
- Setting selected menu items/functions
- Scrolling through the gallery
- Shifting the focus frame
- Exposure lock
- Playback of video recordings
- Confirming the prompts

PLAY BUTTON/MENU BUTTON

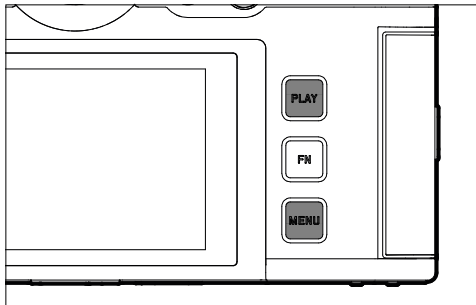

PLAY BUTTON

- Activation and deactivation of the (continuous) review mode
- Return to full-screen display

MENU BUTTON

- Accessing the menu (incl. Control Center)
- Accessing the Play menu
- Exiting the currently displayed (sub) menu

LCD PANEL

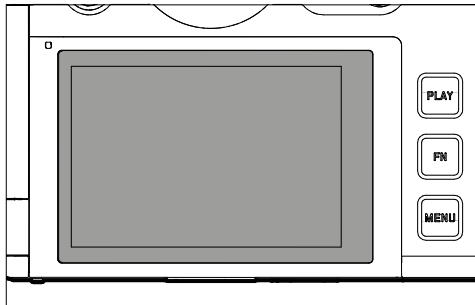

- Displaying most important current settings
- Quick access to some menus
- Touch control

FOLDING OUT THE SCREEN

The screen can be folded out and up or out and down. A convenient feature for taking pictures from a very low or very high perspective.

The screen folds out in two steps.

Folding out the screen

- Grasp the screen at the upper edge.
- Carefully fold out the screen along the hinge on the lower edge

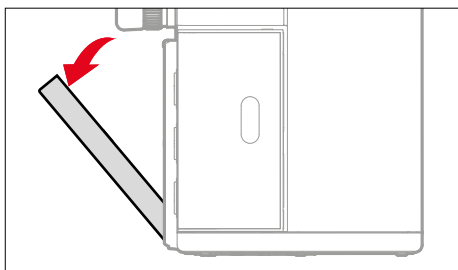
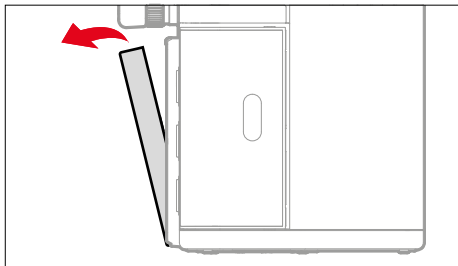

Aligning the screen

- Once folded out, the screen can be rotated around its center axis to see the desired angle

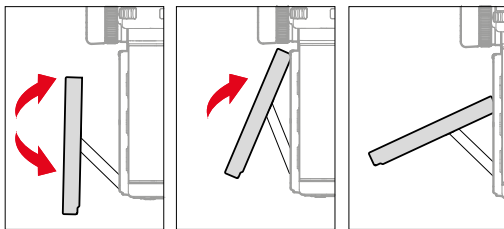





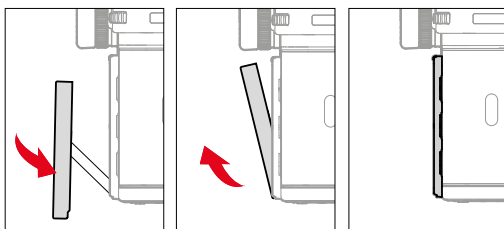

Folding the screen in

- Swivel the screen downward on its center axis as needed
- Once straight, fold the screen along its hinge on the bottom edge to lie flat against the rear of the camera



LCD PANEL (TOUCH SCREEN)

| TOUCH CONTROL* | | In shooting mode | In review mode | Menu | Control Center |
|--|---|--|--|--------------------|--------------------------------------|
|  | "tap" | Shifting the AF frame and focusing (while Touch AF is activated) | Selecting images | Confirm/ Select | |
|  | "double tap" | Resetting the AF frame (while Touch AF is activated) | Enlarging/reducing viewed images | | |
|  | "swipe" | | Scrolling through the gallery Shifts the enlarged image section | Go back one level | |
|  | "horizontal swipe" | Mode change (photo/video) | Scrolling through the gallery | | Mode change (photo/video) |
|  | "vertical swipe" | Switching to review mode | Switching to shooting mode | Scrolling | Switching to shooting mode |
|  | "tap and hold" | Accessing the AF Quick Setting | | | Changing function button assignments |
|  | "two-finger pinch" "two-finger spread" | Changing the size of the AF frame (using the AF modes Field and Eye/ Face/Body Detection) | Enlarging/reducing viewed images | | |
|  | "swipe and hold" "hold and swipe" | | Continuous scrolling | | |

* A light touch is enough, don't apply pressure.

FUNCTION BUTTONS

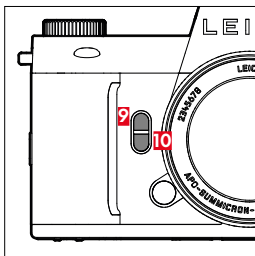
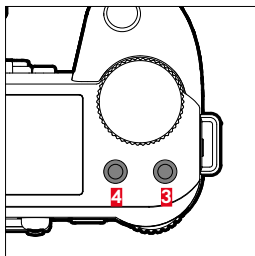
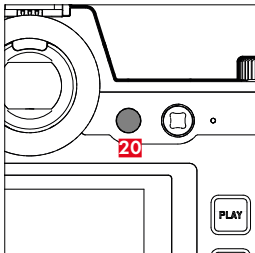
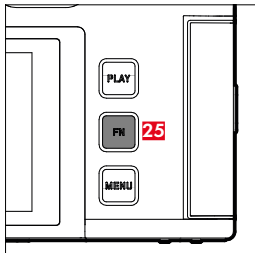

Direct access to various menus and functions. All function buttons can be custom configured (see p. 72).

| FACTORY SETTINGS | |
|-----------------------------|------------------------|
| In shooting mode | In review mode |
| FN button (25) | |
| Toggle info profiles | |
| Function button (20) | |
| LCD panel/EVF switchover | |
| Function button (4) | |
| Mode change (photo/video) | Delete image |
| Function button (3) | |
| – Photo: ISO | Marking/rating a image |
| – Video: ISO | |
| – (Cine): ASA | |
| Function button (2) | |
| – Photo: Magnification | |
| – Video: Microphone Gain | |
| Function button (10) | |
| Autofocus metering method | |

TOP DISPLAY

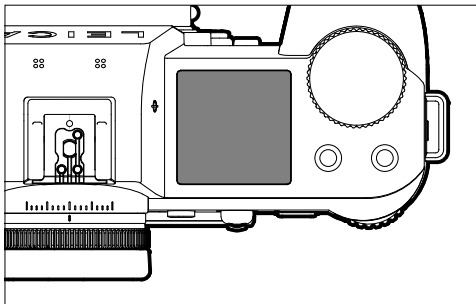

- Display of the active mode
- Display of image data
- Display of camera information

MENU CONTROL

CONTROL ELEMENTS

The following elements are used for menu control.

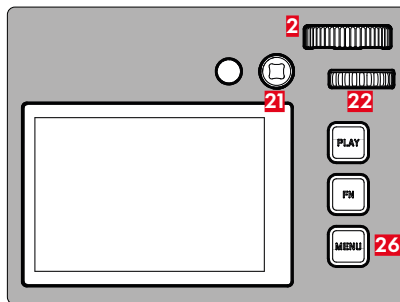

21 Joystick

2 Right dial

26 MENU button

22 Thumbwheel

MENU SECTIONS

Two menu areas are available: Control Center and Main Menu.

Control Center:

- quick access to the most important settings

Main menu:

- offers access to all menu items
- contains various submenus

The currently active operating mode (Photo or Video) is highlighted in color in all menu areas.

| Section | PHOTO | VIDEO |
|----------------|-------------------|-----------------|
| Control Center | Bright background | Dark background |
| Main menu | red line | yellow line |

CONTROL CENTER

Photo

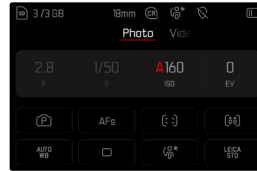

Video

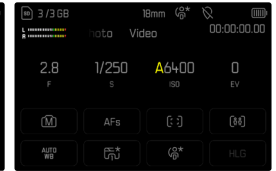

MAIN MENU

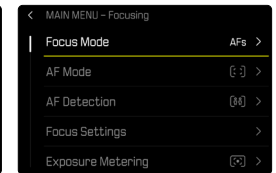
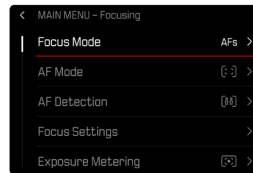

SETTINGS IN PHOTO AND VIDEO MODE

The available settings depend on the operating mode (Photo or Video) currently in use.

- All menu items and their sub items available in the main menu **before** **Storage Management** are mode-specific. That means that any changes made here, will only apply for the operating mode currently in use. Any menu items of the same name in the other operating mode will be unaffected. That includes settings for focusing, exposure metering or white balance.
- All settings and functions after that in the main menu (including **Storage Management**) are available in both operating modes and have global effect. A setting selected in one of the modes will also apply to the other.

Settings and functions with global effect are:

- **Storage Management**
- **Leica FOTOS**
- **USB Charging**
- **USB Mode**
- **Wi-Fi**
- **User Profile**
- **Camera Settings**
- **Camera Information**
- **Language**

SWITCHING MENU SECTIONS

The Control Center will always be displayed as the first menu section. The top level of the menu is organized into “pages”, which are displayed in the header: Control Center and several sections of the Main Menu. You can switch between menu sections by scrolling through the pages.

Scrolling forward

→ Press the **MENU** button

or

→ Turn the right dial in clockwise direction

- The Control Center will reappear after the last page of the Main Menu was displayed.

or

→ Swipe up

Scrolling backward

→ Turn the right dial in anti-clockwise direction

- The last page of the Main Menu will reappear after the Control Center was displayed.

or

→ Swipe down

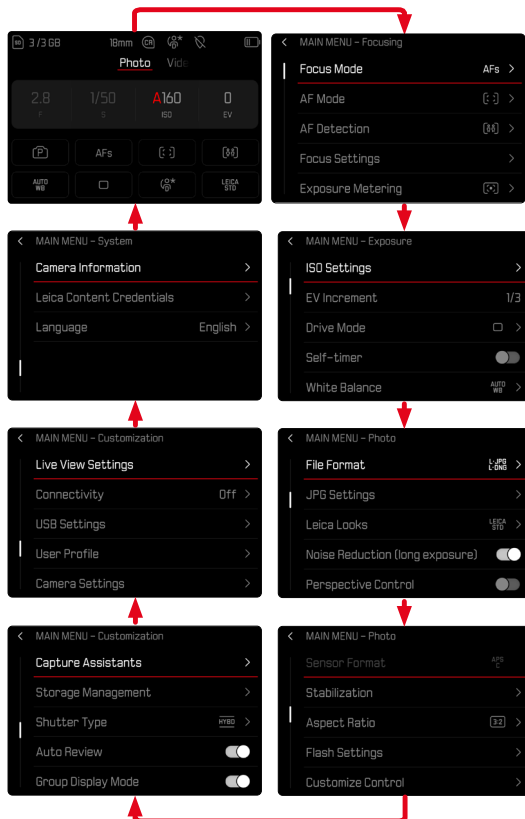

CONTROL CENTER

The Control Center offers an overview of key data relating to the current camera status and active settings. It furthermore allows direct access to important settings. The Control Center is optimized for touch control.

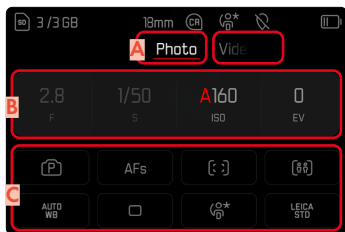

- A** Mode: photo/video (see p. 234)
- B** Exposure settings (see p. 141 and p. 263)
- C** Menu items

Notes

- Where touch control is not possible or not desirable (e.g. in EVF mode), the Control Center can alternatively be controlled via the joystick and/or thumb-wheel.
- The settings become effective immediately.
- All lit control panels can be selected. Automatically populated values are grayed out (depending on the currently active exposure mode).
- The available menu items in photo and video mode differ (see p. 28 and p. 30).

CUSTOMIZING THE CONTROL CENTER

The order of menu items in the Control Center can be customized via touch operation.



| Photo | Video |
|---------------------|---------------------|
| Exposure Mode | Exposure Mode |
| Focus Mode | Focus Mode |
| AF Mode | AF Mode |
| AF Detection | AF Detection |
| White Balance | White Balance |
| Drive Mode | Video Profiles |
| User Profile | User Profile |
| Leica Looks | Leica Looks |
| Exposure Metering | Exposure Metering |
| File Format | AF Setup |
| iDR | Microphone Gain |
| Sensor Format | iDR |
| Shutter Type | Log Settings |
| Self-timer | ISO Increment |
| AF Profiles | Gray card |
| Format Storage | Format Storage |
| Flash Settings | Timecode |
| Image Overlay | Image Stabilization |
| Perspective Control | Headphone Volume |
| Aspect Ratio | Camera Settings |
| Connectivity | Connectivity |

SETTINGS

There are a variety of options for changing settings from within the Control Center. The setting types vary from menu to menu.

- Tap the desired control panel
 - The relevant menu appears.

DIRECT SETTINGS

A version of the menu bar appears in the lower area of the Control Center (see p. 68).



- Select the desired function directly or swipe

MAIN MENU

The main menu offers access to all settings. Most of these are organized in submenus.

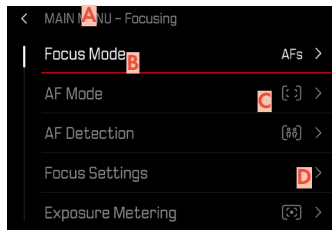

- A** Menu section: **Main Menu**
- B** Menu item name
- C** Menu item setting
- D** Submenu reference

Note

- The entire menu section can be controlled via joystick, dials, or touch.

SUBMENU

There are various types of submenus available. The following pages describe their operation.

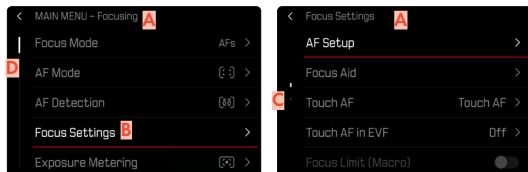

- A** Current menu item
- B** Submenu item
- C** References to other submenus
- D** Scrollbar

MENU NAVIGATION

SCREEN BY SCREEN NAVIGATION

Scrolling forward

→ Press the **MENU** button (repeatedly if needed)

or

→ Turn the right dial in clockwise direction

- The Control Center will reappear after the last page of the Main Menu was displayed.

→ Swipe down

Scrolling backward

→ Turn the right dial in anti-clockwise direction

- The last page of the Main Menu will reappear after the Control Center was displayed.

→ Swipe up

LINE BY LINE NAVIGATION

(Function/function option selection)

→ Press the joystick up/down

or

→ Turn the thumbwheel

(to the right = down, to the left = up)

- Once the last menu item has been reached scrolling up or down, the display will automatically jump to the previous or next screen. The currently active menu section (Favorites, Main Menu) is not exited.

or

→ Swipe up

Note

- Some menu items can only be accessed under specific circumstances. The text in the relevant line is displayed in gray to signify the existence of a submenu.

SHOW SUBMENU

→ Press the joystick/thumbwheel

or

→ Press the joystick to the right

or

→ Tap the menu item

CONFIRM SELECTION

→ Press the joystick/thumbwheel

- The screen image changes back to the active menu item. The set function variant is shown on the right in the relevant menu line.

or

→ Tap the menu item

Note

- No confirmation is needed for the selection of **On** or **Off**. An automatic save is done.

GO BACK ONE STEP

(Return to the superordinate menu item)

- Press the joystick to the left
 - This option is only available for list-type submenus.

or

- Swipe to the right

GO BACK TO TOP MENU LEVEL

- Press the **MENU** button 
 - The top level of the currently selected menu section is displayed.

EXITING THE MENU

You can exit the menus and submenus at any time – with/without applying the settings selected there.

Go to shooting mode

- Tap the shutter button

Go to review mode

- Press the **PLAY** button

SUBMENU

KEYBOARD/NUMBER PAD

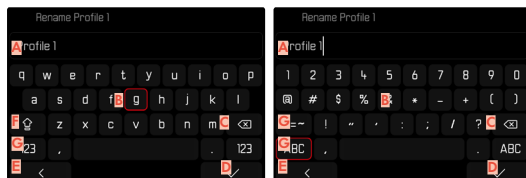

- A** Entry line
- B** Keyboard/Number pad
- C** “Delete” button (deletes the last character entered)
- D** “Confirm” button (to apply individual values and existing settings)
- E** Return to previous menu level
- F** Shift key (toggles between upper and lower case letters)
- G** Changing the character type

SELECTING A BUTTON (ICON/FUNCTION BUTTON)

Using joystick control

- Press the joystick in the relevant direction
 - The currently active button will be highlighted.

- Press the joystick/thumbwheel

or

- Turn the thumbwheel
 - The currently active button will be highlighted.
 - There will be an automatic jump to the next/previous line when the end/beginning of the line is reached.

- Press the joystick/thumbwheel

Using touch control

- Press the button of your choice

SAVE

- Select button **D**

CANCEL

- Select button **E**

MENU BAR

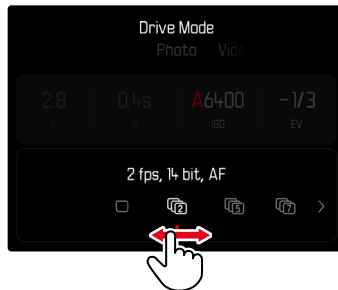

Using joystick control

- Press the joystick left/right

or

- Turn the thumbwheel

Using touch control

- Select the desired function directly or swipe

Notes

- The currently active setting displayed in the center is highlighted in red.
- The set value is displayed above the scale/below the menu bar.
- The following applies for direct access: The selected function requires no additional confirmation and will be active immediately.
- The menu will close automatically after 3 seconds of inactivity. The most recently selected option will then be applied.

SCALE MENU

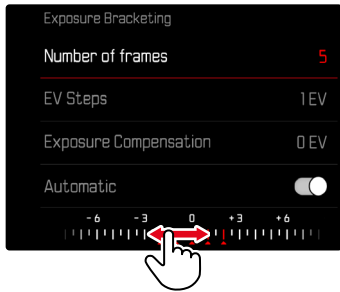

Using button control

→ Press the joystick left/right

or

→ Turn the thumbwheel

Using touch control

→ Select the desired setting directly or swipe

Notes

- The currently active setting displayed in the center is highlighted in red.
- The set value is displayed above the scale/below the menu bar.

DATE/TIME MENU

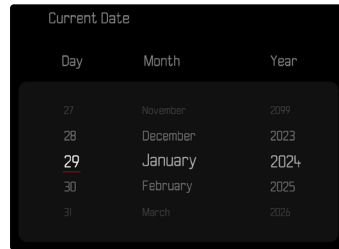

Moving to the next settings field

→ Press the joystick left/right

or

→ Turn the thumbwheel

Setting values

→ Press the joystick up/down

Saving and returning to superordinate menu item

→ Press the joystick/thumbwheel

COMBI MENU (AF PROFILES)



The setting of the individual menu items is done via a setting bar in the lower display area.

Accessing individual menu items

→ Press the joystick in the relevant direction

or

→ Turn the thumbwheel

Setting individual items

→ Press the joystick/thumbwheel

- The set value displayed next to the menu item is highlighted.

→ Press the joystick left/right

or

→ Turn the thumbwheel

Applying the setting

→ Press the joystick/thumbwheel

Returning to the superordinate menu item

→ Press the joystick to the left

COMBI MENU (LEICA LOOKS)



A "Back" button (Exit without saving)

B Menu item "Contrast"

C Menu item "Highlight"

D Menu item "Shadow"

E Menu item "Sharpness"

F Menu item "Saturation"

G "Confirm" button (Save and exit)

The operation is slightly different, depending on whether the settings are done via key control or touch control.

The screen image will remain visible continuously while settings are being adjusted. The result of the setting can be observed directly.

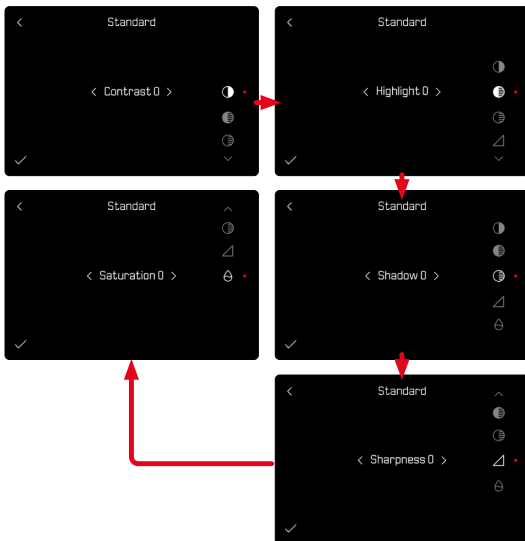

Using button control

Navigating between buttons

- Press the joystick up/down
 - The relevantly active button is indicated by a red dot.

Applying setting

- Press the joystick left/right
 - The button toggles directly between each of the options.
- Press the joystick
 - Confirming the settings

Using touch control

- Tap the desired button
- Tap the symbols "<>" to select a setting.

SAVE

- Select the "Confirm" button

CANCEL

- Select the "Back" button

USER-DEFINED OPERATION

DIRECT ACCESS TO MENU FUNCTIONS

You can assign specific menu functions to the function buttons for extra quick direct access to menu items in shooting mode. The assignments in photo and video mode are completely independent of each other. The available functions are shown in the list on p. 60. For factory settings see p. 55.

CHANGING AN ASSIGNMENT

All function buttons permit a quick and easy reassignment of functions in addition to access to their currently assigned menu function.

- Switch to the desired mode (photo or video)
- Press and hold the desired function button
 - The direct access appears on the LCD panel.

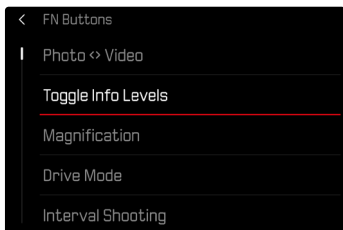

- Select the desired menu item

ACCESSING THE ASSIGNED MENU FUNCTION

- Briefly press and release the desired function button
 - The assigned function is accessed, or a submenu appears on screen.

Notes

- The submenus accessed via direct access may look differently than when they are accessed via the main menu. Specifically, they often appear as menu bars to allow quick settings.
- The settings can be done via key control or using touch control on the LCD panel. The operating mode depends on the type of submenu.

DIAL ASSIGNMENTS (IN SHOOTING MODE)

The function of the two dials depends on the active exposure mode. Wheel assignments can be specified independently for photo and video mode and for every exposure mode. The two control elements can furthermore have functions assigned independently.

FUNCTION ASSIGNMENT

- Switch to the desired mode (photo or video)
- Select **Customize Control** in the main menu
- Select **Dials**
- Select **Dials (AF lenses)/Dials (MF lenses)**
- Implementing the desired assignment

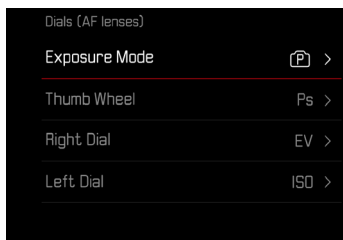

Selecting the desired exposure mode

- Press the joystick up/down
 - Currently available assignment options are highlighted in red.

Assigning a function to the thumbwheel

- Turn the thumbwheel
 - The available thumbwheel assignment options cycle through.

Assigning a function to the right dial

- Turn the right dial
 - The assignment for the right dial cycles through the available functions.

Saving the assignment and exiting the menu

- Press the joystick to the left
- or
- Tap the shutter button
- or
- Press the **MENU** button

WHEN USING AF LENSES

The available functions are listed in the tables below (the factory setting is highlighted in bold).

Photo mode

| | Thumbwheel | Right dial |
|---|--|--|
| P | Program shift Exposure compensation ISO | Program shift Exposure Compensation ISO |
| S | Exposure Compensation Shutter speed ISO | Exposure compensation Shutter speed ISO |
| A | Aperture Exposure compensation ISO | Aperture Exposure Compensation ISO |
| M | Aperture Shutter speed ISO | Aperture Shutter speed ISO |

Video mode

| | Thumbwheel | Right dial |
|---|--|--|
| P | Microphone Gain Exposure compensation ISO | Microphone Gain Exposure Compensation ISO |
| S | Exposure Compensation Shutter speed ISO | Exposure compensation Shutter speed ISO |
| A | Aperture Exposure compensation ISO | Aperture Exposure compensation ISO |
| M | Aperture Shutter speed ISO | Aperture Shutter speed ISO |

WHEN USING MF LENSES

The available functions are listed in the tables below (the factory setting is highlighted in bold).

Photo mode

| | Thumbwheel | Right dial |
|----------|--|--|
| A | Magnification Exposure compensation ISO | Magnification Exposure Compensation ISO |
| M | Magnification Shutter speed ISO | Magnification Shutter speed ISO |

Video mode

| | Thumbwheel | Right dial |
|----------|--|--|
| A | Magnification Exposure compensation ISO | Magnification Exposure compensation ISO |
| M | Magnification Shutter speed ISO | Magnification Shutter speed ISO |

ROTATION DIRECTION OF THE DIALS

You can specify any rotation direction for exposure settings via the dials. You specify the rotation direction, which will result in an exposure reduction (shorter shutter speeds/smaller aperture).

The assignments for the two dials are done separately independent of each other in photo and video mode.

THUMBWHEEL/RIGHT DIAL/LEFT DIAL

- Switch to the desired mode (photo or video)
- Select **Customize Control** in the main menu
- Select **Dials**
- Select **Dial Direction**

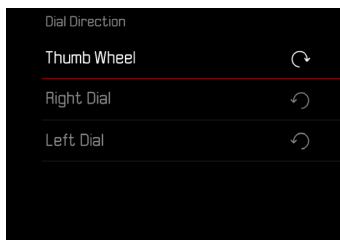

JOYSTICK FUNCTIONS (IN SHOOTING MODE)

You can assign various functions to the joystick in photo mode. The settings for AF and MF mode are done separately. See p. 119, p. 129 and p. 153 for the various functions.

AF MODE

- Select **Customize Control** in the main menu
- Select **Joystick**
- Select **AF Mode**
- Select the desired setting
(**AF-L**, **AE-L**, **AF-L + AE-L**, **AF-ON**)

MF MODE

- Select **Customize Control** in the main menu
- Select **Joystick**
- Select **MF Mode**
- Select the desired setting
(**Magnification**, **AFs**, **AFs + AE-L**, **AFc**, **AFc + AE-L**, **AE-L**)

LOCKING THE OPERATING ELEMENTS

Various operating elements can optionally be locked in shooting mode.

LOCKING THE DIALS

- Select **Customize Control** in the main menu
- Select **Joystick**
- Activate **Dial Lock**

LOCKING THE JOYSTICK

- Select **Customize Control** in the main menu
- Select **Dials**
- Activate **Joystick Lock**

Note

-  appears on screen when a operating element is used while the lock is active.

USER PROFILES

This camera allows the permanent storage of any menu settings, to e.g. access them quickly and easily for recurring conditions/image objects. Six memory slots are provided to store custom settings, plus the factory setting, which is always available and cannot be modified (**Default Profile**). You can assign names for the saved profiles yourself.

Any profiles configured for the camera can be saved to a memory card for use on another camera. Similarly, profiles saved on a memory card can be transferred to the camera.

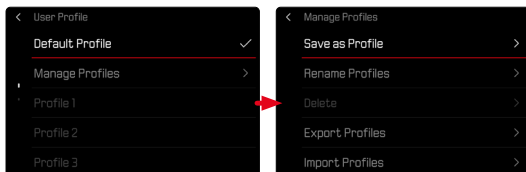

Note

- The lens list is not part of the user profiles.

CREATING PROFILES

Saving settings/creating a profile.

- Create custom settings for the desired functions via menu control
- Select **User Profile** in the main menu
- Select **Manage Profiles**
- Select **Save as Profile**
- Select a memory slot

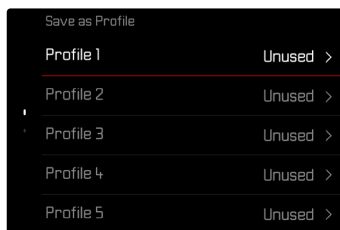

- Confirm the selection

Note

- Existing profiles are overwritten with the latest settings.

RENAMING PROFILES

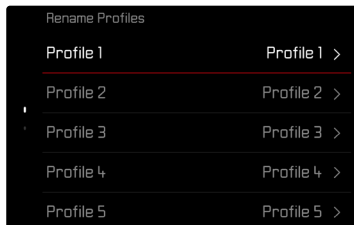

- Select **User Profile** in the main menu
- Select **Manage Profiles**
- Select **Rename Profiles**
- Select a profile
- Enter a name for the profile via the associated sub-menu keyboard and confirm your input (see p. 67)
 - Profile names must be between 3 and 10 characters in length.

APPLYING/ACTIVATING PROFILES

Factory setting: **Default Profile**

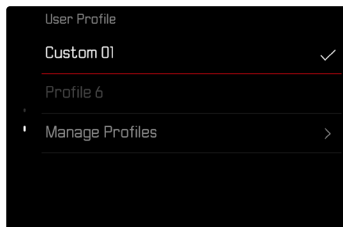

- Select **User Profile** in the main menu
 - A list of profile names is displayed.
- Select a profile
 - The selected profile is marked as **Active**.
 - Free memory slots appear in gray.

INDICATOR REGARDING UNSAVED USER PROFILES

A star icon  will appear in the Control Center and in the sidebar to indicate a changed/ not yet saved user profile in the current firmware.

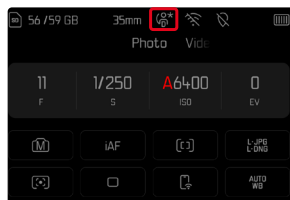

Note

- User profiles that will continue to be used after a firmware update may similarly be indicated with this star icon , as some profile settings are dependent on the firmware version in use. Where that is the case, we recommend exporting the existing user profiles followed by a reset of the camera to its factory settings, and a subsequent reloading of the user profile.

EXPORTING/IMPORTING PROFILES TO/FROM THE MEMORY CARD

- Select **User Profile** in the main menu
- Select **Manage Profiles**
- Select **Export Profiles** or **Import Profiles**
- Confirm the selection

Notes

- When importing and exporting, all profile slots are transferred to the card, i.e. including any empty slots. Any existing profiles stored in the camera will be overwritten, during the profile import. Individual profiles cannot be imported or exported.
- Any existing set of profiles will be replaced on the memory card during an export without an acknowledgment prompt.

CAMERA BASIC SETTINGS

The two menu items **Language** and **Date & Time** appear automatically when switching the camera on for the first time, after a reset to factory settings (see p. 292), or after a firmware update. Additionally, you have the option to have the Leica FOTOS app set up the camera's **Date & Time** (including Time Zone and Daylight Saving Time). The settings will be automatically applied from those of your smartphone.

MENU LANGUAGE

Factory setting: English

Available menu languages: German, French, Italian, Spanish, Portuguese, Russian, Japanese, Korean and Traditional or Simplified Chinese

- Select **Language** in the main menu
- Select your language
 - Aside from a few exceptions, the language will be changed for all information.

DATE/TIME

DATE

You can choose one of 3 options for the display sequence.

- Select **Camera Settings** in the main menu
- Select **Date & Time**
- Select **Date Setting**
- Select **Date Format**
- Select the desired date format
(**Day/Month/Year**, **Month/Day/Year**, **Year/Month/Day**)
- Set the date

TIME

- Select **Camera Settings** in the main menu
- Select **Date & Time**
- Select **Time Setting**
- Select **Time Format**
- Select the desired brightness
(**12 Hours**, **24 Hours**)
- Set the time
(Select **am** or **pm** for the 12-hour format)

TIME ZONE

- Select **Camera Settings** in the main menu
- Select **Date & Time**
- Select **Time Zone**
- Select your time zone/current location
 - The Greenwich Mean Time offset is shown on the left of the line
 - Major cities in the relevant time zones are shown on the right

DAYLIGHT SAVING TIME

- Select **Camera Settings** in the main menu
- Select **Date & Time**
- Select **Daylight Saving Time**
- Activate the function

DISTANCE UNIT

The distance can be displayed in meters or in feet (see p. 119).

Factory setting: **Meter (m)**

- Select **Camera Settings** in the main menu
- Select **Distance Unit**
- Select the desired setting (**Meter (m)**, **Feet (ft)**)

POWER SAVE MODE (STANDBY MODE)

The camera will switch to the power-saving standby mode after a preset time to extend battery life if this function is activated.

The device has two power save levels.

- Standby mode is activated after
30 s/1 min/2 min/5 min/10 min
- Automatic LCD panel shutdown (see p. 85)

Factory setting: 2 min

- Select **Camera Settings** in the main menu
- Select **Power Saving**
- Select **Auto Power Off**
- Activate the function
- Select **Settings**
- Select the desired setting
(30 s, 1 min, 2 min, 5 min, 10 min)

Note

- The camera can be woken from standby mode at any time by pressing the shutter button or by switching the main switch off and on again.

LCD PANEL/VIEWFINDER SETTINGS

The camera comes equipped with a 3" liquid crystal color panel, which is protected by a glass cover made of extremely hard and scratch-resistant glass.

The following functions can be configured and used individually:

- Use of the LCD panel and EVF (electronic viewfinder)
- Eye sensor sensitivity
- Brightness
- Color rendering
- Automatic LCD panel and EVF shutdown

LCD PANEL/EVF USE

You can preset the situations in which EVF and LCD panel should be used. The displays appearing on screen and in the electronic viewfinder are identical.

The setting toggles to **LCD** automatically when the screen is folded out. The original setting resumes, once the screen is folded back in.

Factory setting: **Auto**

| | EVF | LCD panel |
|---------------------|---|--|
| Auto | The eye sensor in the viewfinder automatically toggles the camera between LCD panel and EVF. <ul style="list-style-type: none">• Shooting• Review• Menu control | |
| LCD | | <ul style="list-style-type: none">• Shooting• Review• Menu control |
| EVF | <ul style="list-style-type: none">• Shooting• Review• Menu control | |
| EVF extended | Only EVF is used for shooting mode. The eye sensor in the viewfinder automatically toggles the camera between LCD panel and EVF for review and menu control. <ul style="list-style-type: none">• Shooting• Review• Menu control | |

→ Select **Display Settings** in the main menu

→ Select **EVF <> LCD**

→ Select the desired setting

Note

- Select **EVF** if you want to keep the LCD panel switched off (e.g. on dark environments).
- Important information is displayed on screen, e.g. during a firmware update.

EYE SENSOR SENSITIVITY

You can adjust the eye sensor sensitivity to ensure that the changeover functions reliably if you wear eyeglasses.

Factory setting: **High**

→ Select **Display Settings** in the main menu

→ Select **Eye Sensor Sensitivity**

→ Select the desired setting

BRIGHTNESS

You can adjust brightness for best visibility in various lighting conditions. Brightness is set individually for the LCD panel and the viewfinder. Selection occurs via key control or touch control.

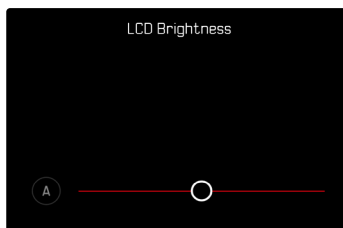

LCD PANEL

- Select **Camera Settings** in the main menu
- Select **Display Settings**
- Select **LCD Brightness**
- Select the desired brightness or **A** (Auto)
- Confirm selection

EVF

- Select **Display Settings** in the main menu
- Select **EVF Brightness**
- Look through the viewfinder
- Select the desired brightness
- Confirm selection

Note

- The setting **Auto** is not available here.

COLOR RENDERING

Color rendering can also be adjusted. Brightness is set individually for the LCD panel and the viewfinder. Selection occurs via key control or touch control.

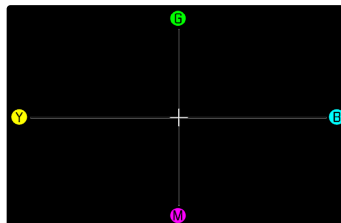

LCD PANEL

- Select **Camera Settings** in the main menu
- Select **Display Settings**
- Select **LCD Color Adjustment**
- Select the desired color setting
- Confirm selection

EVF

- Select **Display Settings** in the main menu
- Select **EVF Color Adjustment**
- Look through the viewfinder
- Select the desired color setting
- Confirm selection

AUTOMATIC LCD PANEL AND EVF SHUTDOWN

The LCD panel and EVF deactivate automatically to save power. The time until power off can be set. This setting also affects autofocus; the AF system will be deactivated at the time of automatic shutdown as well. We therefore recommend the **Off** setting if autofocus is to be used in HDMI recordings.

Factory setting: **1 min**

- Select **Camera Settings** in the main menu
- Select **Power Saving**
- Select **Displays/AF Auto Off**
- Activate the function
- Select **Settings**
- Select the desired setting
(**30 s**, **1 min**, **5 min**)

EVF FRAME RATE

The image frequency of the EVF can be set.

Factory setting: **60 fps**

- Select **Display Settings** in the main menu
- Select **EVF Frame Rate**
- Select the desired setting
(**60 fps**, **120 fps**)

Note

- We recommend the **120 fps** setting for highly dynamic scenes. However, this setting will significantly increase power consumption.
- The setting **120 fps** is available only while the camera is not overheating. Once temperature increases excessively, the setting will be automatically reduced to **60 fps**.

LCD FRAME RATE

The image frequency for the LCD panel can be selected.

Factory setting: **30 fps**

- Select **Display Settings** in the main menu
- Select **LCD Frame Rate**
- Select the desired setting
(**30 fps**, **60 fps**)

Note

- The setting **60 fps** increases power consumption and may result in a significantly higher camera temperature.

AUTOMATIC ROTATION OF THE INFO BAR

The info bar can be automatically rotated for shoots in vertical position. The content and sequence of the displayed data will not change.

Factory setting: **On**

- Select **Camera Settings** in the main menu
- Select **Display Settings**
- Select **Rotate Info Bars**
- Activate the function

ACOUSTIC SIGNALS

Some functions can be acknowledged with acoustic signals. The following special functions can be configured separately:

- Electronic shutter sound
- AF confirmation
- Notification Signals

VOLUME

The volume of active signals can be set.

Factory setting: **Low**

- Select **Camera Settings** in the main menu
- Select **Acoustic Signal**
- Select **Volume**
- Select **Low/High**

ACOUSTIC SIGNALS

This setting specifies, whether the camera shout output general notification signals, e.g. during the delay time of the self-timer or as a warning signal, when the memory card is full.

Factory setting: **Off**

- Select **Camera Settings** in the main menu
- Select **Acoustic Signal**
- Select **Notification Signals**
- Activate the function

ELECTRONIC SHUTTER SOUND

Factory setting: **Off**

- Select **Camera Settings** in the main menu
- Select **Acoustic Signal**
- Select **Electronic Shutter Sound**
- Activate the function

AUTOFOCUS CONFIRMATION

A signal sound can be selected for successful AF settings.

Factory setting: **Off**

- Select **Camera Settings** in the main menu
- Select **Acoustic Signal**
- Select **AF Confirmation**
- Activate the function

SILENT PHOTOGRAPHY

When pictures should be taken as quietly as possible.

- Select **Camera Settings** in the main menu
- Select **Acoustic Signal**
- Select **Electronic Shutter Sound/AF Confirmation/Notification Signals**
- Select **Off** for each of these menu items

FILE FORMAT

Choose the JPG format **JPG** or the standardized raw data format **DNG** (= digital negative). Both can be used individually or simultaneously.

When creating JPGs, an initial processing occurs in the camera. Various parameters, including contrast, saturation, black level, or edge sharpness are set automatically. The result is then compressed and stored. The immediate result is an image that is optimized for various uses and a quick preview. For post-processing, on the other hand, DNG images are recommended.

DNG files contain all raw data as recorded by the camera sensor at the time the photo is taken. Special software (e.g. Adobe® Photoshop® Lightroom® or Capture One Pro®) will be needed to display DNG format files or to work with this format. Post-processing will allow exact adjustments of many parameters to your own expectations.

Factory setting: **L-DNG / L-JPG**



→ Select **File Format** in the main menu

→ Select a format

(**L-DNG**, **S-DNG**, **L-DNG/L-JPG**, **L-DNG/S-JPG**, **S-DNG/L-JPG**, **S-DNG/S-JPG**, **L-JPG**, **S-JPG**)

Notes

- The standardized DNG format is used for the storage of raw image data.
- The remaining number of shots shown in the LCD panel will not necessarily change after every shooting. That very much depends on the object; very fine image structures result in higher data quantities, while homogeneous surfaces mean less data.

ASPECT RATIO

You have a choice of aspect ratios to select in addition to the basic 3:2 (e.g. 1:1). The relevant cropped section will be displayed. Images made in JPG format are saved with the relevant aspect ratio. DNG images will always have the natural sensor format (3:2), the set aspect ratio is only in aid of the image composition. In review mode, DNG images will be displayed with horizontal or vertical auxiliary lines showing the cropped section seen when shooting.

Factory setting: 3:2

- Select **Aspect Ratio** in the main menu
- Select the desired setting
(3:2, 7:5, 4:3, 1:1, 3:1, 16:9)

IMAGE PROPERTIES

LEICA LOOKS

The image properties of pictures can easily be changed using a variety of parameters. These are summarized in pre-configured **Leica Looks** profiles. Furthermore, additional Leica Looks can be downloaded and transferred via Leica FOTOS.

Pre-installed are:

- **Standard**
- **Vivid**
- **Natural**
- **Monochrome**
- **Monochrome High Contrast**

- Select **Leica Looks** in the main menu
- Select a profile

CUSTOMIZING LEICA LOOKS

Leica Looks are individually customizable.

LOOKS CONFIGURATION FRAME

| Customizable | Only intensity | Not customizable |
|---|--|---|
| Core Looks (Standard, Vivid, Natural, Monochrome, Monochrome High Contrast) | Essential Looks (Teal, Chrome, Eternal etc.) | Artist or Partner Looks (Greg Williams) |

Note

- This information may change with the addition of new Leica Looks.

- Select **Leica Looks** in the main menu
- Select a profile
- Select **Customize**
- Select **Intensity/Contrast/Highlight/Shadow/Sharpness/Saturation**
- Select the desired level
(-2, -1, 0, +1, +2)
- **Intensity** can be set as a percentage as needed

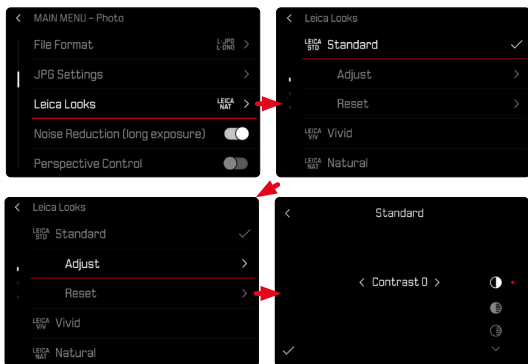

DOWNLOADING LEICA LOOKS

Additional Leica Looks can be downloaded and transferred via Leica FOTOS.

- Select **Leica Looks** in the main menu
- Select **Download Leica Look**

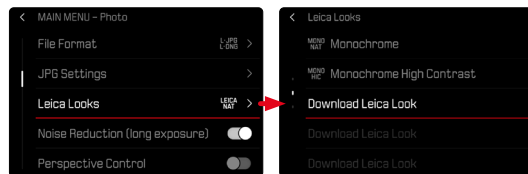

RESETTING LEICA LOOKS

- Select **Leica Looks** in the main menu
- Select **Restore**

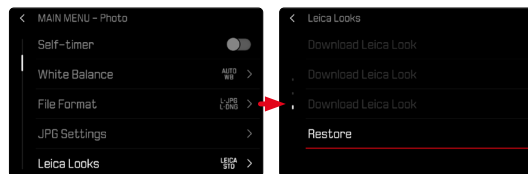

Note

- Only customizable Leica Looks can be reset.

AUTOMATIC OPTIMIZATION

NOISE REDUCTION

NOISE REDUCTION FUNCTION FOR LONG-TERM EXPOSURE

In digital photography, the appearance of flawed pixels that can be white, red, blue or green is referred to as "noise". Image noise becomes more apparent when using higher sensitivities, particularly on uniform dark areas. Long exposure times may cause severe image noise. In order to reduce this annoying phenomenon, the camera will take a second "dark frame" (taken with the shutter closed) automatically after a shooting with slow shutter speed and high ISO value. The noise metered in this parallel shot will then be "subtracted" digitally from the data for the actual shot. In such cases the message **Noise reduction in progress...** will appear with a relevant time value.

This "exposure time" doubling must be taken into account in long-term exposures. The camera must not be switched off during that time. We recommend disabling Noise Reduction to allow shooting multiple frames in series and to apply noise reduction later during the post-editing stage. The images will have to be taken in raw data format.

Factory setting: **On**

- Select **Noise Reduction (long exposure)** in the main menu
- Select **On**

Under certain conditions, noise reduction will always be active as long as the function is enabled. That includes shots taken with the T function, as well as long-term exposure frames with shutter speeds of $\geq +8$ s.

In all other cases, noise reduction depends on a combination of factors (specifically ISO setting, exposure time, and sensor temperature). The following table contains a list of shutter speeds typical for a sensor temperature of 25°C, at which noise reduction would be applied.

| ISO | Shutter speed longer than |
|--------------|---------------------------|
| 100 | 7 s |
| 200 | 6.4 s |
| 400 | 5.9 s |
| 800 | 5.4 s |
| 1600 | 4.9 s |
| 3200 | 4.5 s |
| 6400 | 4.2 s |
| ≥ 12500 | 3.8 s |

NOISE REDUCTION IN JPG IMAGES

Except when high sensitivities are used, noise is luckily negligible. Nevertheless, noise reduction is a component of data processing when JPG files are generated. On the other hand, since it also has an effect on the focus review, you can optionally weaken or strengthen this noise reduction in comparison to the standard setting.

Factory setting: **Low**

- Select **JPG Settings** in the main menu
- Select **Noise Reduction (JPG)**
- Select the desired setting
(**Low**, **Medium**, **High**)

Note

- This setting will only affect images in JPG format.

IMAGE STABILIZATION

The less favorable the lighting conditions during shooting, the slower will be the required shutter speeds for correct exposure. Visual image stabilization is a great tool for preventing out-of-focus images due to blurring.

Factory setting: **Auto**

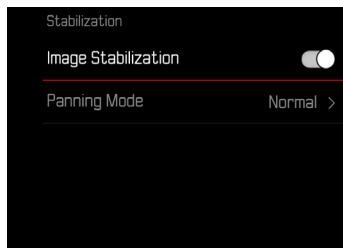

- Select **Stabilization** in the main menu
- Select **Image Stabilization**
- Activate the function

SETTING THE STABILIZATION DIRECTION

For camera pans it can be useful to only correct camera shake in specific directions.

Factory setting: **Normal**

- Select **Stabilization** in the main menu
- Select **Panning Mode**
- Select the desired setting
(**Normal**, **Auto Panning**, **Vertical Panning**, **Horizontal Panning**)

Note

- Some lenses may not support all settings offered in the camera. Please contact Leica Customer Care if you have any questions (see p. 332).
- The toggle function for image stabilization switches between **Off** and the most recently selected setting (e.g. **Auto**). This function can be assigned to a function button.

DARK AREA OPTIMIZATION (iDR)

DYNAMIC RANGE

The contrast range of an object comprises all levels of brightness from the brightest to the darkest point in the image. All levels of brightness can be captured by the sensor, provided the contrast range of the object is lower than the dynamic range of the camera. In case of significant differences of brightness in the object (e.g. shootings of interior spaces with bright windows in the background, shootings with subject elements in shadow or directly lit by the sun, landscapes with dark areas and a very bright sky), the camera with its limited dynamic range will not be able to map the entire contrast range of the object. Information in 'edge areas' will be lost (under and overexposure).

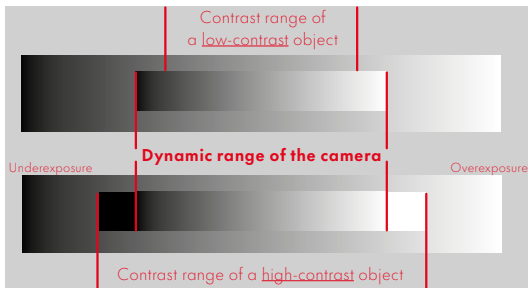

iDR FUNCTION

The **iDR** (Intelligent Dynamic Range) function allows an optimization of the darker areas. Object details become much clearer. This function will only affect images in JPG format.



You can specify beforehand if and to what extent you want to optimize darker areas (**High**, **Standard**, **Low**, **Off**). In the **Auto** setting, the camera will automatically select the right setting depending on the contrast range of the object. In addition to that setting, the effect also depends on the exposure settings. The function will have the strongest effect in combination with low ISO values and fast shutter speeds. The effect is less pronounced with higher ISO values and/or slower shutter speeds.

Factory setting: **Auto**

- Select **JPG Settings** in the main menu
- Select **iDR**
- Select the desired setting (**Auto**, **High**, **Standard**, **Low**)

Notes

- The optimization of darker areas will slightly reduce differentiation in very bright areas.
- This function will only affect images in JPG format.

DATA MANAGEMENT

STORAGE OPTIONS

There are a number of options for saving data when two memory cards are inserted.

- **DNG+JPG on CF_e=SD**
- **DNG+JPG first on CF_e**
- **DNG on CF_e / JPG on SD**

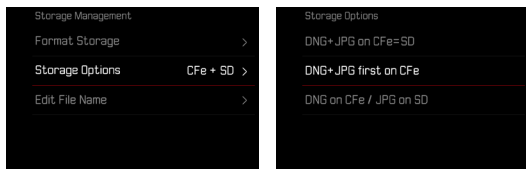

| | |
|---------------------------------------|---|
| CF_e = SD (Backup) | All files are saved to CF _e and SD. One of the cards therefore serves as backup. |
| CF_e + SD (Standard) | Files are saved to CF _e first, until its capacity is reached. Subsequent files will then be saved to SD. |
| CF_e / SD (Split) | Files are saved separately depending on their format: DNG files are saved to CF _e , and JPG files to SD. |

An icon in the Control Center denotes the selected setting.

Factory setting: **DNG+JPG first on CF_e**

- Select **Storage Management** in the main menu
- Select **Storage Options**
- Select the desired setting
(**CF_e = SD**, **CF_e + SD**, **CF_e / SD**)

FORMATTING A MEMORY CARD

Memory cards that have already been in use with this camera will usually not require formatting. An unformatted memory card that is inserted into the camera for the first time must be formatted. We recommend formatting memory cards from time to time, because residual data traces (data pertaining to individual shots) may reduce the card's memory capacity.



- Select **Storage Management** in the main menu
- Select **Format Storage**
- Select **Format CF_e Card** / **Format SD Card**
- Confirm the selection
 - The status LED will flash during the process.

FORMATTING AN EXTERNAL USB SSD

A connected external USB SSD data medium can be formatted via the camera menu. Previously used data media will generally not have to be formatted. New data media, or data media connected for the first time may have to be formatted before initial use.



- Select **Storage Management** in the main menu
- Select **Format Storage**
- Select **Format USB-SSD**
- Confirm the selection
 - The status LED will flash during the process.

Notes

- Never switch off the camera while data transfer is in progress.
- All previously stored data on the data medium will be lost during formatting. Formatting will not be prevented by a deletion protection set for individual shots.
- The formatting time will depend on the size of the data medium and may take several seconds for larger media. There will be no additional information displayed during that time.
- All images should therefore be regularly transferred to a safe mass storage medium, e.g. the hard disk.
- The simple formatting process will initially not irretrievably destroy existing data. Only the directory will be deleted, which means the data will no longer be directly accessible. Data access can be restored with appropriate software. Only data that is overwritten when new data is saved will actually be irretrievable.
- A memory card should be formatted again in the camera if it was formatted in another device, e.g. a computer.
- Contact your retailer or Leica Customer Care for assistance if the memory card cannot be formatted/overwritten.

EXTERNAL DATA MEDIUM

The use of an external SSD data medium may be a good solution for storing large data volumes. Photos and videos can then be recorded directly onto a suitable SSD drive via USB-C. The device offers a formatting feature for SSD data media connected via USB-C.

- Select **USB Settings** in the main menu
- **USB SSD** activation

Notes

- A simultaneous recording via USB-C to an SSD data medium and CFe/SD card is not possible.
- SSD data media with a capacity up to 2TB are supported.
- When using the device battery (BP-SCL4), the reduced power availability will prevent the use of external USB-C data media.
- Some functional limitations (8K, 4K, slow motion video recordings, continuous shooting, and the Wi-Fi connection) may occur, once the rechargeable battery has reached a specific discharge threshold.
- USB hubs and USB card readers are not supported.
- The system will need approx. 8 seconds to check the connected external drive and to change mode, once an external USB-C data medium is connected.

DATA STRUCTURE

FOLDER STRUCTURE

The files (= photos) on the memory cards are saved in automatically generated folders. The first three characters signify the folder number (numerals), the last five the folder name (letters). The first folder is assigned the name "100LEICA", the second "101LEICA". A folder will always be created with the next available number; you can have max. 999 folders.

FILE STRUCTURE

The file names in these folders consist of eleven characters. In the factory settings, the first file is named "L1000001.XXX", the second "L1000002.XXX", etc. The first letter can be selected, the "L" from the factory settings denotes the camera brand. The first three characters signify the folder number (numerals). The next four digits denote the sequential file number. Once file number 9999 is reached, then a new folder will be automatically created, in which the file numbering begins at 0001 again. The last three places after the dot denote the file format (DNG or JPG).

Notes

- When using memory cards that were not formatted with this camera, the file numbering will begin with 0001 again. Should the memory card already contain a file with a higher number, then numbering will be continued from that number.
- A relevant message will be displayed on the LCD panel once folder number 999 and file number 9999 are reached, and all numbering must be reset.
- Format the memory card and reset the frame number right after to reset the folder number to 100.

EDIT FILE NAMES

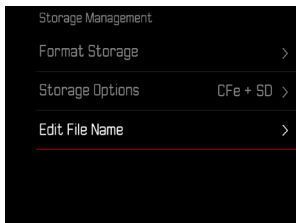

- Select **Storage Management** in the main menu
- Select **Edit File Name**
 - A keyboard submenu is displayed.
 - The input line contains the factory setting "L" as the first letter of the file name. Only this letter can be changed.
- Enter a letter of your choice (see p. 69)
- Confirm

Notes

- The change to a file name applies to all subsequent files or until a new change is made. The sequential number will not be affected; but it will be reset when a new folder is created.
- During a reset to factory settings, the first letter will always be reset to "L".
- Lower case letters are unavailable.

CREATING A NEW FOLDER

- Select **Camera Settings** in the main menu
- Select **Reset Image Numbering**
 - A relevant prompt is displayed.
- Confirm the creation of a new folder (**Yes**) or cancel the new folder (**No**)

Note

- The name part (first letter) of a new folder created this way remains unchanged. The file numbers in that folder will start again at 0001.

CONTENT CREDENTIALS (LEICA CONTENT CREDENTIALS)

Signing the images with this function allows you to add allocation details to each frame. They contain information about the identity of the creator, as well as data in compliance with the C2PA standard regarding the specific camera used for taking the images. These may offer useful allocation information for target groups, once the image is shared or published. Relevant images are marked with an  icon.

- Select **Leica Content Credentials** in the main menu
- Activate the function (**On**) under the menu item **Sign Content**
- Select **Copyright/Produced by** from the submenu
 - A keyboard submenu is displayed.
- Enter the desired information
- Confirm
 - The  icon is displayed in shooting mode.

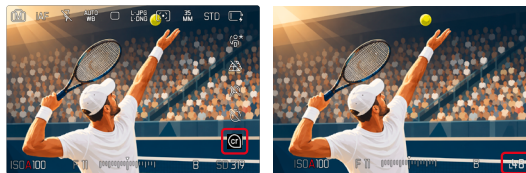

- Tap and hold the shutter button to toggle the display to an image counter. This image counter shows the max. number of possible single images.

Disclaimer

- “Leica Content Credentials” allow the tracing of image content and changes thereto. Leica Camera AG assumes no liability with regard to tamper safety or misuse, and offers no warranty for the use of the “Leica Content Credentials” for a specific purpose.

LOGGING THE SHOOTING LOCATION (ONLY IN CONNECTION WITH THE LEICA FOTOS APP)

Location information can be sourced from a mobile device in connection with the Leica FOTOS app. Current location information will then be written to the Exif data of the images (geotagging).



- Activating GPS functions on a mobile device
- Activate Leica FOTOS and connect to the camera (see chapter "Leica FOTOS")
- Activate geotagging for this camera in Leica FOTOS

Notes

- The use of GPS and associated technologies may be restricted in some countries or regions. Violations will be prosecuted by local authorities. You should therefore contact your travel agent or the embassy of your destination country for relevant information beforehand.
- It will take a few seconds for the Bluetooth connection to establish. The configured shutdown time should be considered when choosing a delay time if shutdown is enabled in the camera.
- All images with location information are marked with the geotagging icon in review mode.

GEOTAGGING STATUS

The status of existing location information is displayed on screen, provided the info bars are displayed and geotagging is enabled. The Control Center will always show the current geotagging status.

| | |
|---|---|
|  | The location information is current (most recent geolocation max. 15 mins prior). |
|  | The location information is not necessarily current anymore (most recent geolocation max. 12 h prior). |
|  | The available location information is outdated (most recent geolocation more than 12 h in the past). No location data will be written to Exif data. |
| No icon | Geotagging is deactivated. |

Location information will be continuously updated as long as the camera is connected to Leica FOTOS. The Bluetooth function of the camera and the mobile device must therefore remain enabled to ensure latest information. It is, however, not necessary for the app to be running in the foreground.

DATA TRANSFER

VIA LEICA FOTOS APP

→ See chapter “Leica FOTOS” (p. 292)

VIA USB CABLE OR “LEICA FOTOS CABLE”

The camera supports multiple data transfer options. A transfer mode can be permanently selected or chosen every time a connection is established.

Factory setting: **Select on Connection**

→ Select **USB Mode** in the main menu

→ Select the desired setting

(**Mass Storage**, **PTP**, **Apple MFi**, **Select on Connection**)

- **Apple MFi** is used for the communication with iOS devices (iPhone and iPad)
- **PTP** allows a data transfer to computers using macOS or Windows with PTP-capable programs, as well as tethering to Capture One Pro and Lightroom Classic
- The setting **Select on Connection** will automatically propose a connection method depending on the type of cable connection.

Notes

- We recommend using a card reader for the transfer of large files.
- The USB connection must not be interrupted while data is being transferred, as the computer or the camera could otherwise “crash” and irreparable damage could occur on the memory card.
- The camera must not be turned off or automatically shut itself down due to a lack of battery power while data is being transferred, as this can cause the computer to crash. For the same reason, the battery must never be removed from the camera while the connection is active.

“CAMERA-TO-CLOUD – FRAME.IO” VIA WLAN

The camera can connect directly to Frame.io via WLAN. With this integration, photos and proxy videos can be uploaded straight from the camera to the cloud – quickly, securely, and without any intermediate steps.

A new **Connectivity** menu item was introduced for this feature, via which **Leica FOTOS** and **Frame.io** can now be configured.

→ Select **Connectivity** in the main menu

→ Select **Frame.io**

→ Select the desired Wi-Fi network

More information about the functional scope of Frame.io:

Product Tour:

<https://my.de/s/Gcig>



Video Tutorial

<https://vimeo.com/1143409148>



Notes

- A simultaneous connection with Leica FOTOS and Frame.io is not possible.
- To upload proxy videos, a CFe card and an SD card must be inserted simultaneously, and the Proxy option must be enabled in the video profile.

PRACTICAL DEFAULT SETTINGS

TOUCH AF

Touch AF allows a direct placement of the AF frame.
Factory setting: **Touch AF**

→ Select **Focus Settings** in the main menu

→ Select **Touch AF**

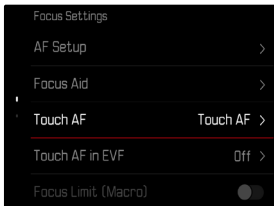

→ Select **Touch AF**

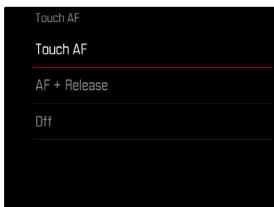

Positioning the AF frame

→ Tap the LCD panel in the desired position

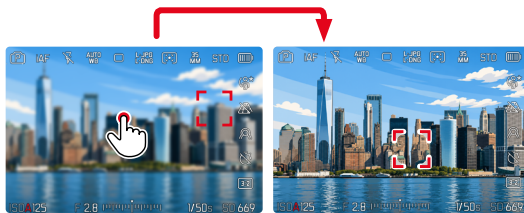

Moving the focus frame back to the center of the screen

→ Double-tap the LCD panel

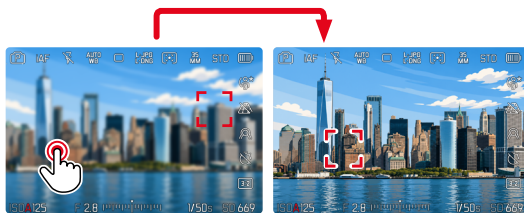

Notes

- This function is available with all AF metering methods except **Multi-Field**.
- The behavior of **Touch AF** depends on the selected combination of **AF Mode** and **AF Detection**. Depending on the setting, the camera will either focus on the selected object (when detection is active) or on the area that was tapped.
- If the metering method **Tracking** is selected, the focus frame will remain at the selected position and auto-focus commences when the shutter button is tapped. For all other AF metering methods, focusing occurs automatically.
- The position of the AF frame can only be reset with a double-tap, even if the setting is **Off**.

TOUCH AF + SHUTTER BUTTON

The combination **Touch AF + Release** allows a direct placement of the AF frame for immediate recording.

- Select **Focus Settings** in the main menu
- Select **Touch AF**
- Select **Touch AF + Release**
- Tap the LCD panel in the desired position

Note

- The AF frame cannot be reset as usual via a double tap if **Touch AF + Release** is activated.

TOUCH AF IN EVF MODE

Touch AF is deactivated by default when EVF is in use to prevent any inadvertent altering of the AF frame. AF Quick Setting continues to be accessible. This function can also be disabled if that is not wanted (e.g. when focusing with the left eye).

Factory setting: **Off**

- Select **Focus Settings** in the main menu
- Select **Touch AF in EVF**
- Select the desired setting
(**On**, **AF Quick Setting only**, **Off**)
- **AF Quick Setting only**
 - Accessing the AF Quick Setting (tap and hold)
- **On**
 - Positioning the AF frame (tap)
 - Accessing the AF Quick Setting (tap and hold)
- **Off**

PERSONALIZED LENS SETTINGS

The total angle of rotation of the lens used for focusing can be individually adjusted. The setting selected indicates the angle of rotation required to change the focus setting from infinity to the nearest possible distance.

Example: for a setting to **90°**, the entire focus range will be run through when the focus ring is turned by one quarter. A full turn of the focus ring will be needed for a setting to **360°**. Smaller values facilitate a faster, larger values a more precise adjustment. A setting to **Maximum** offers the highest precision.

Unlike the permanent settings, a setting to **Standard MF** will result in a non-linear dependency of rotation angle and focus setting. The extent of the change depends dynamically on the speed of rotation. With slow rotation, the same angle of rotation (e.g. 45°) causes a smaller change than with fast rotation.

Factory setting: **Standard MF**

→ Select **Focus Settings** in the main menu

→ Select **Manual Focus Throw**

→ Select the desired setting

(**Standard MF**, **90°**, **120°**, **150°**, **180°**, **210°**, **240°**, **270°**, **300°**, **330°**, **360°**, **Maximum**)

Notes

- The settings **Standard MF** and **Maximum** are highly lens-dependent. **Maximum** may, for example, mean a rotation angle of 360° or 720°.

EV INCREMENT

You can choose between 1/2 EV or 1/3 EV graduations. This will allow you to choose between stronger or more subtle effects for your relevant settings.

This setting doesn't just apply for exposure compensation settings. It also specifies the sensitivity of the dials in standard shooting mode, i.e. the increment width with which the shutter speeds and the aperture will be set. A setting to **1/2** will change the shutter speeds and aperture values that much faster each time the dial is moved one click further and the correct setting is achieved quicker. A setting to **1/3** facilitates a more precise setting.

Factory setting: **1/3**

→ Select **EV Increment** in the main menu

→ Select the desired setting
(**1/2**, **1/3**)

AUXILIARY DISPLAYS

The Leica SL3-P has 4 independent info profiles, which contain differing combinations of the available auxiliary displays. The following functions are available:

- Info Bars (see p. 109)
- Grids (only shooting mode, see p. 110)
- Focus Peaking (see p. 110)
- Clipping (see p. 110)
- Level Gauge (only shooting mode, see p. 112)
- Histogram (see p. 112)

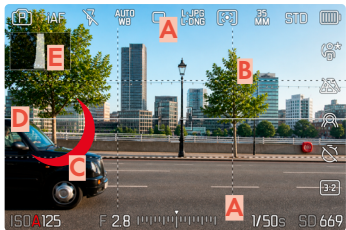

- A** Info bars (= header, footer, bar on the right)
- B** Grid lines
- C** Focus peaking
- D** Clipping
- E** Level gauge
- F** Histogram

INFO PROFILES

Up to 4 independent profiles can be used, plus an additional full-screen mode. The desired function can be selected and adjusted individually for each profile. During operation, the switch between info profiles is done via direct access (see p. 74). In factory settings, that will be the **FN** button. It allows quick switches between various views.

The following profiles are predefined in the factory settings:

| Profile | Factory Settings | |
|---------|--|--|
| 1 | Info bars only (Top / Bottom) | |
| 2 | Full screen view (all auxiliary displays Off) | |
| 3 | Info Bars (Top / Bottom + Right), Clipping, Focus Peaking, Histogram | |
| 4 | Info Bars (Top / Bottom + Right), Grids, Clipping, Level Gauge | |

CHANGING THE INFO PROFILES

- Press the function button with the **Toggle Info Levels** assignment
 - In factory settings, that will be the **FN** button.

Note

- The same info profiles are available in review mode as in shooting mode. The actual info profile currently in use, however, is saved separately.

Briefly showing/hiding information

- Tap and hold the shutter button
 - (Only) the exposure information and currently active auxiliary functions will be visible.

DEACTIVATING INDIVIDUAL INFO PROFILES

You can limit the number of info profiles by activating/deactivating individual profiles. At least one profile must always be active, but that can be an “empty” profile.

- Select **Capture Assistants** in the main menu
- Select a profile
- Select **On/Off**

Note

- At least one Info Profile must be activated.
- Info Profile 5 (full screen without display) cannot be deactivated.

CUSTOMIZING THE INFO PROFILES

- Select **Capture Assistants** in the main menu
- Select a profile
- Select **Settings**
- Select the desired function
- Select the desired setting

| Function | Available settings |
|---------------|---|
| Info Bars | Top / Bottom (On, Off) Right (On, Off) |
| Grids | 3 x 3, 6 x 4, Off |
| Clipping | Off, Upper Limit (value between 200 and 255) |
| Focus Peaking | On, Off Color (Red, Blue, Green, White) & Sensitivity (Low, Medium, High): Settings apply for all info profiles |
| Level Gauge | On, Off |
| Histogram | On, Off |

Note

- It is advisable to reserve one info profile as “empty”, in which all functions are set to **Off**. It allows you to temporarily hide all displays. In effect, you get an unobstructed view of the full screen image.

SHOW AVAILABLE

INFO BARS

The icons displayed represent currently active settings and exposure values. See chapter “Displays” for a full list of the various displays (see p. 28).



GRID LINES

The grids divide the image frame into multiple fields. They facilitate pictorial composition and an exact camera orientation. The grid line distribution can be adjusted to fit the object.

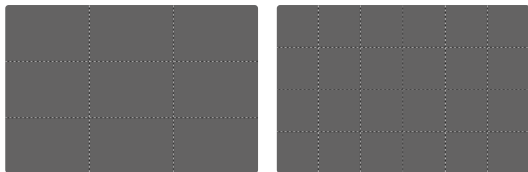

You can choose one of two grid displays. They divide the image field into 3 x 3 or 6 x 4 fields.

- Select **Capture Assistants** in the main menu
- Select a profile
- Select **Settings**
- Select **Grids**
- Select the desired setting
(**3 x 3**, **6 x 4**, **Off**)

CLIPPING

The Clipping display marks very bright image areas. This function is a very easy and exact tool for checking the correct exposure setting. Overexposed areas flash black.



SETTING THE LIMIT VALUE

You can set a threshold value for these displays, i.e. define a value at what degree of overexposure they will appear, so that you can adjust these displays to specific conditions or in line with your own composition ideas.

- Select **Capture Assistants** in the main menu
- Select a profile
- Select **Settings**
- Select **Clipping**
- Select **Upper Limit**
- Select the desired value
(**200** to **255**)

- Tap and hold the shutter button
 - The clipping display appears.

FOCUS PEAKING

This assist function highlights the edges of in focus subject elements in color. The color can be user-specified. The sensitivity can be additionally adjusted.

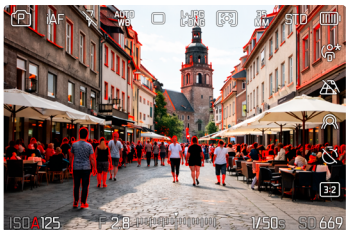

HIGHLIGHT COLOR

The color can be user-specified. This setting will apply for all info profiles.

Factory setting: **Red**

- Select **Capture Assistants** in the main menu
- Select a profile
- Select **Settings**
- Select **Focus Peaking**
- Select **Color**
- Select the desired setting
(**Red**, **Green**, **Blue**, **White**)

SENSITIVITY

Factory setting: **Medium**

- Select **Capture Assistants** in the main menu
- Select a profile
- Select **Settings**
- Select **Focus Peaking**
- Select **Sensitivity**
- Select the desired setting
(**Low**, **Medium**, **High**)

Note

- Focus peaking is based on subject contrast, i.e. differences between light and dark. As a result, high contrast subject elements could be marked, even if they are not completely in focus.

LEVEL GAUGE

The integrated sensors of the camera show its orientation. These indicators ensure exact camera orientation along the longitudinal and transverse axes of critical objects, e.g. architecture.

Deviations in relation to the longitudinal axis (i.e. when the camera is tilted up or down in the direction of view) are indicated by a short line in the center of the image (1).

Deviations in relation to the transverse axis (when the camera is tilted to the left or right) are indicated by two long lines to the left and right of the image center (2).

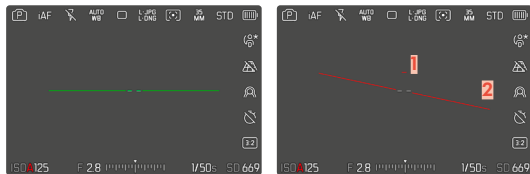

- Select **Capture Assistants** in the main menu
- Select **Level Gauge**
- Select **On/Off**

Note

- The camera will switch the aspect of the level gauge autonomously for shoots in vertical format.

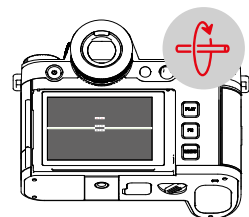
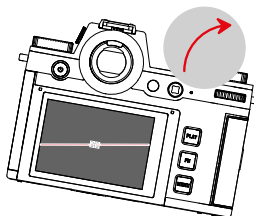
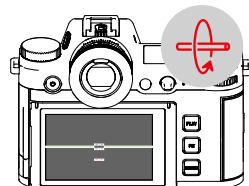
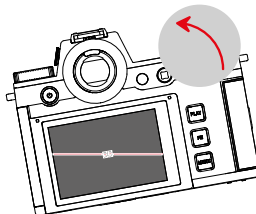
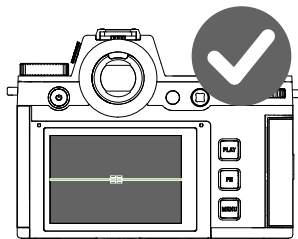

HISTOGRAM

Histogram represents the brightness distribution in the image. The horizontal axis shows the graduated values from black (left) through gray to white (right). The vertical axis corresponds to the number of pixels at each brightness level.

This type of rendering allows an additional quick and easy assessment of the exposure setting.



- Select **Capture Assistants** in the main menu
- Select a profile
- Select **Settings**
- Select **Histogram**
- Select **On/Off**

Notes

- The histogram is always based on the brightness displayed; depending on the settings used, it may not represent the final exposure.
- In shooting mode, the histogram should be regarded as a “trend indicator”.
- The histogram during rendering may differ slightly from the one during exposure.
- The Histogram always refers to the currently displayed cropped section of the image.

TEMPORARY ACTIVATION/DEACTIVATION OF INDIVIDUAL FUNCTIONS

The following assist functions can be activated/deactivated temporarily:

- Focus peaking
- Clipping
- Assigning the desired assist function to a function button (see p. 74)
- Press the corresponding function button
 - The status of the assist function toggles On/Off.
 - A relevant indicator appears in the screen image.

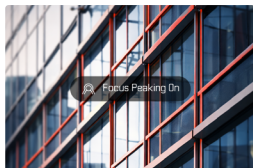

The temporary setting is reset when the camera is switched off.

ENHANCED LIVE VIEW

Image composition is often difficult in very dark environments (e.g. at night), as the objects are barely visible. The function **Enhanced Live View** will assist the image composition in such situations. The image is enhanced in Live View based on a significant increase in the ISO value and a reduced refresh rate. Image quality will not be impacted. Due to technical issues, there will, however, be image noise and severe tracer effects in Live View mode. This function will only be active in very low ambient light.

Depending on the selected exposure mode and other settings, Live View will display an exposure preview when the shutter release button is tapped and held (see section "Exposure control" beginning on page 152).

- Select **Live View Settings** in the main menu
- Select **Enhanced Live View**
- Select **On**

Notes

- The function will be inactive even if **Enhanced Live View** is set to **On** if there is sufficient ambient light.
- In AF mode, the function **Enhanced Live View** will be intermittently inactive during range metering.
- **Focus Peaking** will be unavailable when **Enhanced Live View** is set to **On**.

MF ASSIST FUNCTIONS

AF ASSIST LAMP

The integrated AF assist lamp allows operation of the AF system in unfavorable lighting conditions. This lamp comes on while metering is performed, provided the function is activated.

Factory setting: **On**

- Select **Focus Settings** in the main menu
- Select **Focus Aid**
- Select **AF Assist Lamp**
- Activate the function

Notes

- The AF assist lamp illuminates an area of up to approx. 5 m.
- The AF assist lamp switches off automatically, once focusing was successful (AF frame is green) or has failed (AF frame is red).

ACOUSTIC AF CONFIRMATION

You can set an acoustic confirmation signal for successful focus metering in AF mode.

Factory setting: **Off**

- Select **Camera Settings** in the main menu
- Select **Acoustic Signal**
- Select **AF Confirmation**
- Activate the function

PHOTOGRAPHY

The settings described in this chapter only apply for photo mode. They are therefore part of the photo menu and must always be accessed and configured from within photo mode (see chapter “Camera operation” in the section “Menu Control”). Any menu items of the same name in the video menu are entirely independent of these.

DRIVE MODE

The functions and settings described in the following generally refer to the exposure of individual shots. In addition to single frame shooting, the Leica SL3-P offers a number of other exposure modes. Please read the relevant sections for information about functionalities and setting options.

- Select **Drive Mode** in the main menu
- Select the desired function options

| Mode | Setting options / Variants |
|----------------------------------|---|
| Single frame shooting | Single |
| Continuous shooting (see p. 155) | Speed: <ul style="list-style-type: none">– 2 fps, 14 bit, AF– 5 fps, 14 bit, AF– 7 fps, 14 bit, AF– 15 fps, 12 bit, AF– 15 fps, 14 bit, AF– 25 fps, 12 bit, AF– 25 fps, 14 bit, AF– 30 fps, 12 bit, AF– 40 fps, 12 bit, AF |
| Interval shooting (see p. 156) | Number of Frames Interval between the shootings (Interval) Delay time (Countdown) |
| Exposure bracketing (see p. 158) | Number of Frames (3 or 5) EV Steps Exposure Compensation Automatic |
| Multishot (see p. 159) | Delay time (Self-timer) Motion artefacts correction |
| Self-timer (see p. 159) | Delay time: <ul style="list-style-type: none">– Self-timer 2 s– Self-timer 6 s– Self-timer 12 s– Self-timer 30 s |

FOCUSING

Your Leica SL3-P allows automatic as well as manual focusing. There are 3 operating modes and 7 metering methods available for AF photography. Only manual setting options are available for MF lenses.

AF PHOTOGRAPHY

- Select the desired AF mode
- Position the AF frame as needed
- Tap and hold the shutter button
 - Focusing occurs one time (AFs) or continuously (AFc).
 - Metering was successful: The AF frame lights up green.
 - Metering was unsuccessful: The AF frame lights up red.
 - Alternatively, focusing and/or exposure settings can be done and saved via the joystick (see “Metering memory lock” on p. 151).
- Shutter release

MF PHOTOGRAPHY

- Select as focus mode **MF** (see p. 129)
- Use the focus ring to manually focus on the object
- Shutter release

Please read the following chapters for more information.

AUTOFOCUS MODES

The following AF modes are available: **AFs**, **AFc** and **Intelligent AF**. The currently selected AF mode is shown in the header line.

Factory setting: **AFs**

- Select **Focus Mode** in the main menu
- Select the desired setting (**Intelligent AF**, **AFs**, **AFc**)

INTELLIGENT AF (iAF)

In this mode, the camera will refocus as soon as it registers a color or brightness/contrast change in the entire image section. The focus field depends on the autofocus metering method selected.

AFs (single)

Suitable for objects with little or no movement. Focusing is done only once and the setting remains as long as the shutter button is held at the pressure point. That also applies if the AF frame is pointed at another object.

AFc (continuous)

Suitable for objects in motion. As long as the shutter button is held at the 1st pressure point, focusing is continuously adjusted to the object in the AF frame.

AF FOCUS METERING METHODS

The AF mode offers various metering methods for focusing. A successful focus setting is identified by a green frame, an unsuccessful one is shown in red.

In the **AF Mode** section, the focusing types **Field / Spot**, **Zone / Multi-Field**, and **Tracking** can be selected. Under **AF Detection**, the functions **Eye/Face/Body Detection** and **Animal Detection** are available. They allow a flexible combination of autofocus behavior and subject recognition.



- Select **AF Mode** in the main menu
- Select the desired setting
(**Field / Spot**, **Zone / Multi-Field**, **Tracking**)

Notes

- AF focusing can be unsuccessful:
 - if the distance to the subject is too great or too small
 - if the object is not sufficiently illuminated
- Touch AF allows a direct placement of the AF frame.

ZONE/MULTI-FIELD METERING

Multiple focus frames in one area are detected automatically. The size of this area can be changed much like the AF frame (see “Accessing AF quick settings”), and with it the area in which focal points are detected. This feature is particularly useful for snapshots and combines well with Eye/Face/Body Detection.

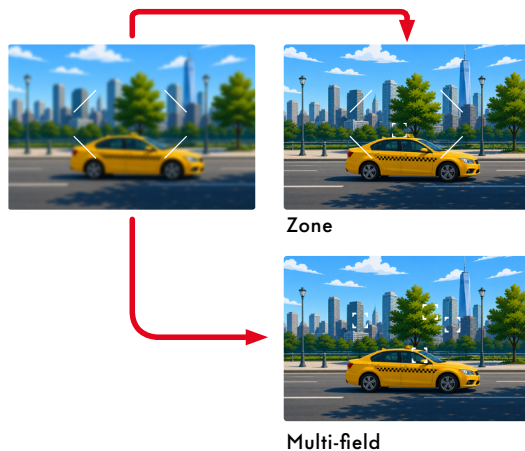

FIELD/SPOT METERING

Both methods detect the parts of the subject elements within the relevant AF frames. The metering fields are indicated by a small frame (field metering) or a cross (spot metering). The very small measuring range for spot metering allows focusing on tiny details of the subject. The smallest possible frame setting corresponds to spot metering.

The slightly larger measuring range in field metering is less critical for focusing, but still permits selective metering.

These metering methods can also be used for serial exposures in which the part of the object you want to focus on will always be at the same off-center position in the image. Simply move the AF frame to another position.

TRACKING

This field metering variant helps in the capture of moving objects. The focus on the object in the focus frame is continuously adjusted, once it is detected.

- Aim the focus frame at the desired object (by panning the camera shifting the focus frame)
- Tap and hold the shutter button

or

- Press the function button (provided it was assigned the function **AF-L** or **AF-L** + **AE-L**, see p. 151)
 - The camera focuses on the object.
- Pan the camera to the desired cropped section
 - The focus frame “tracks” the saved object and focus is continuously adjusted.

Note

- This metering method focuses continuously, even if the AF mode **AFs** was set.

START POSITION FOR TRACKING

Factory setting: **Center**

You can specify the starting point for tracking.

| | |
|----------------------|---|
| Center | Center of the screen |
| Last Position | Ending position of the most recent tracking Example: A car drives through the picture from left to right. The picture is taken on the right edge of the frame. The subsequent measurement is taken at the right edge of the frame. |
| Recall | Starting position of the most recent tracking Example: A car drives through the picture from left to right. The picture is taken on the right edge of the frame. The subsequent measurement is taken at the left edge of the frame. |

- Select **Focus Settings** in the main menu
- Select **AF Setup**
- Select **AF Tracking Start Position**
- Select the desired setting
(**Last Position**, **Recall**, **Center**)

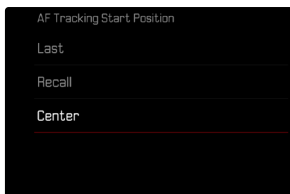

AUTOMATIC SUBJECT RECOGNITION

The camera automatically detects various objects – including people, animals, and vehicles – and focuses specifically on eyes, faces, bodies, or vehicle parts. The main subject remains reliably in focus, even if there is movement or a brief obstruction. Automatic subject recognition provides precise and continuous focus tracking in every shooting situation.

- Select **AF Detection** in the main menu
- Select the desired setting
(**Off**, **Human (Eye/Face/Body)**, **Human (Eye/Face)**, **Animal (Body)**, **Animal (Eye/Body)**, **Car**, **Car (Parts)**)

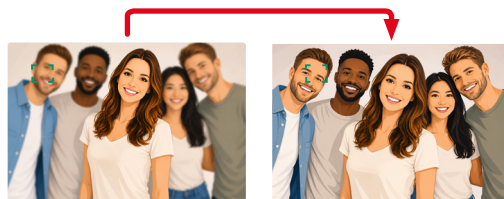

When face detection detects an eye, the focus will be on that eye. Should more than one eye be detected, then the user can choose the eye to focus on. The currently selected eye will be highlighted.

- Press the joystick in the desired direction

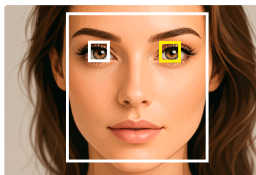

In **Car** detection mode, objects that are further away or moving quickly are prioritized.

- Select **AF Detection** in the main menu
- Select **Car**



Car (Parts) detection is suitable for closer details of the vehicle or driver (bodywork components, helmet etc.).

- Select **AF Detection** in the main menu
- Select **Car (Parts)**



Note

- The subject detection mode **Car** is optimized for race cars; low-contrast road vehicles (e.g. white or gray) may be detected less reliably.

AF MODE / AF DETECTION COMBINATION

With Zone / Multi-Field metering, the desired focus point can be selected from all subjects detected within the measurement area.

- Press the joystick in the desired direction
 - A white outline indicates recognized objects, while a yellow outline highlights the selected object.



AF FRAME IN TRACKING WITH ACTIVATED AF DETECTION

In AF mode, **AF Detection** with activated object detection (person or animal) adapts the display of the tracking frame to the current detection and focusing status.

Behavior in detail

Once the camera detects a suitable object (person or animal), tracking is activated and displayed accordingly. When the shutter button is pressed to the first pressure point without a suitable object being detected in the image field, tracking will remain inactive.

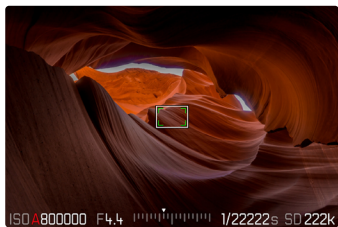

In that case, green markers (corners of the frame) will show that the camera has successfully completed focusing. The frame remains white.

This color coding allows for quick visual confirmation of whether Tracking was activated, or an alternative focusing option was implemented.

AF FRAME IN TRACKING WITHOUT AF DETECTION

When detection mode for persons or animals is not activated, the AF frame signals successful focusing by way of a color change.

Once focus is confirmed, the frame and corners of the AF field will switch from white to green. A green display signals successful focusing on the selected object.

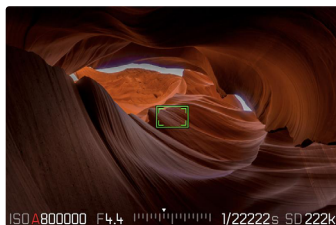

AF SETTINGS

AF PROFILES

Factory setting: Children / Pets

AF profiles allow optimal adjustments to the autofocus behavior depending on the type of object. You specify the sensitivity of the autofocus response to changes in the object.

There are 4 pre-defined AF profiles:



| AF Profile | Typical situation |
|-----------------|---|
| Children / Pets | Standard movements |
| Team Sports | Fast and unexpected change in direction |
| Runner | Constant movements |
| Wildlife | Sudden appearance, change in direction |

Each of these profiles contains three parameters:

- AF Sensitivity
- Field Movement
- Shift in Direction

| Higher values: | Lower values: |
|---|---|
| AF Sensitivity | |
| Changes in the distance to the object are tracked immediately | The adjustment is delayed slightly to prevent unwanted focus jumps, should e.g. a person or object pass in front of the subject |
| Field Movement | |
| In case of movement from within the active focus field, the camera will switch to the next focus field as quickly as possible | Gradual switchover to adjacent focus fields to prevent errors due to slight movements |
| Shift in Direction | |
| The focus will immediately track sudden changes to the movement of the object | More robust focusing during steady movements |

ACCESSING THE ACTIVE PROFILE

- Select **Focus Settings** in the main menu
- Select **AF Setup**
- Select **AF Profiles**

CHANGING THE ACTIVE PROFILE

- Accessing the active profile
- Press the joystick/thumbwheel
 - The currently selected profile is marked as changeable by red lettering and two small white triangles on either side.
- Press the joystick left/right
- or
- Turn the thumbwheel

ADJUSTING THE ACTIVE PROFILE

- Accessing the active profile
- Select desired parameter
- Press the joystick/thumbwheel
- Setting the desired value

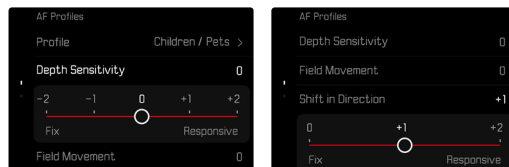

RESETING THE ACTIVE PROFILE

- Accessing the active profile
- Press the joystick to the right
- Press the joystick/thumbwheel

PRE FOCUS

When the function is active, the camera carries out a continuous depth mapping in realtime before the actual focusing. That allows a pre-identification of possible focus points in a scene. It speeds up the autofocus function significantly.

The pre-focus function is compatible with all AF modes and AF metering methods.

Factory setting: **On**

- Select **Focus Settings** in the main menu
- Select **AF Setup**
- Select **Pre Focus**
- Select **On/Off**

FOCUS LIMIT

The focus area can be limited to the macro range. This will speed up automatic focusing considerably.

Factory setting: **Off**

- Select **Focus Settings** in the main menu
- Select **Focus Limit (Macro)**
- Select **On/Off**

Notes

- The focusing range differs depending on the lens used (see relevant instructions).
- This function is not available for specific lenses:
 - lenses mounted via an adapter (e.g. Leica M lenses with L adapter M)
 - This function is available only for specific lenses.

AF QUICK SETTING

The AF Quick Setting allows quick changes to the focus frame size in some AF metering methods. The screen image will remain visible continuously while settings are being adjusted.

ACCESSING AF QUICK SETTING

- Tap and hold the LCD panel
- All auxiliary displays are hidden.
- Markers appear at two corners of the focus frame when the metering method **Field / Spot**, **Zone / Multi-Field** is set.

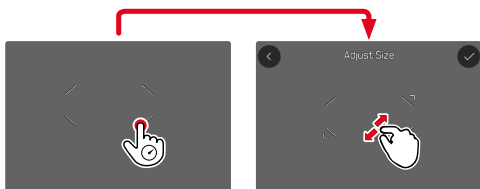
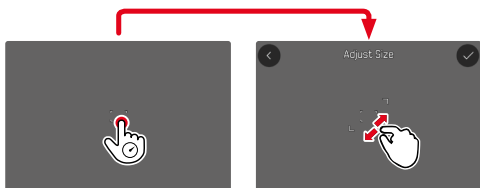

- In all other AF modes, the **AF Mode** menu bar will be displayed directly.

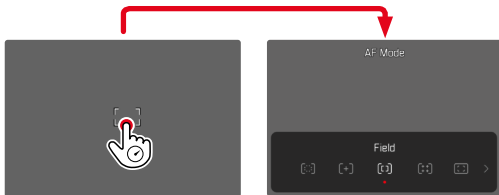

ADJUSTING THE AF FRAME SIZE

(only **Field / Spot**, **Zone / Multi-Field**)

- Turn the thumbwheel

or

- Two-finger pinch/spread
 - The size of the AF frame is adjustable in 3 increments.

CHANGING THE AF METERING METHOD

Should the active AF mode be **Field** or **Eye/Face/Body Detection**, then the user will have to access the **AF Mode** menu bar first:

- Press the function button at the front (bottom)
 - The **AF Mode** menu bar appears.
- Use the thumbwheel to select the desired metering method
 - Alternatively, you can use the right dial for the setting.
 - The setting is applied automatically after 3 seconds, the menu bar disappears.

Note

- AF Quick Setting can only be accessed via the right dial if the function **Touch AF** is active (see p. 75).

MF ASSIST FUNCTIONS

ENLARGEMENT IN AF MODE

You can access the enlargement function independent of focusing for a better assessment of the settings.

The **Magnification** function must be assigned to one of the function buttons to use this feature (see p. 74).

Factory setting: Function button at the front (top)

Assigning a function to a specific function button

→ See p. 74

Accessing the enlargement function

→ Press the function button

- An enlarged image section appears. The position of the enlargement depends on the position of the AF frame.
- The rectangle within the frame at the top right represents the current magnification, as well as its position in the displayed cropped section.



Adjusting the enlargement function

→ Turn the thumbwheel

- The image section toggles between magnification factors.

Changing the position of the enlarged section

→ Press the joystick in the relevant direction

Exiting the enlargement function

→ Tap the shutter button

or

→ Press the function button again

Notes

- The enlargement function remains active until it is exited.
- The most recently magnification function will still be active the next time the feature is accessed.

AF ASSIST LAMP

The integrated AF assist lamp allows operation of the AF system in unfavorable lighting conditions. This lamp comes on while metering is performed, provided the function is activated.

See p. 117 for settings.

ACOUSTIC AF CONFIRMATION

You can set an acoustic confirmation signal for successful focus metering in AF mode (see p. 88).

SHIFTING THE AF FRAME

All AF metering methods permit shifting the AF frame before focusing.

→ Press the joystick in the relevant direction

or

→ Tap the LCD panel in the desired position
(While Touch AF is activated)

Notes

- The focus frame will remain at the most recently used position for this AF metering method even if the user changes the AF metering method or the camera is switched off.
- The metering fields are joined together when the exposure metering method **Spot** is combined with the AF metering methods **Spot**, **Field** and **Zone**. Exposure metering will then occur at the point specified by the AF frame, even if it is moved.

QUICK AF METERING POSITION CHANGES

The function **Toggle Focus Point** allows seamless changes between two metering positions in photo mode.

The position of the AF frame is reset to the center of the image when the function is initially accessed. Whenever the function is accessed after that, the AF frame will jump back and forth between the center of the image and the most recently used focus position.

The function **Toggle Focus Point** must be assigned to one of the function buttons (see p. 74).

Note

- This function is available in the AF modes **Spot**, **Field**, **Zone** and **Tracking**.

MANUAL FOCUSING (MF)

Focusing manually may in some situations be a better choice than autofocus.

- the same setting is used for several shoots
- it would take longer to use the metering memory lock function
- the setting is to be kept at infinity for landscape pictures
- poor, i.e. very dark lighting conditions prevent AF operation or would slow it down

→ Select **Focus Mode** in the main menu

→ Select **MF**

→ Turn the focus ring until the desired part of the object is in clear focus

MF ASSIST FUNCTIONS

The following assist functions are available in MF mode.

FOCUS PEAKING

This assist function highlights the edges of in focus subject elements in color. The color can be user-specified. The sensitivity can be additionally adjusted. See p. 113 for settings.



When Focus Peaking is activated,  will appear to the right of the frame with a display of the color used. The color can be user-specified. The sensitivity can be additionally adjusted. The activation of this function is controlled vis the info profiles (see p. 113).

→ Activate the function

→ Turn the focus ring to mark the desired subject elements

Note

- Focus peaking is based on subject contrast, i.e. differences between light and dark. As a result, high contrast subject elements could be marked, even if they are not completely in focus.

ENLARGEMENT IN MF MODE

The larger the details of the object are shown, the better you can assess their sharpness and the more accurately you can focus.

This function can be automatically activated during manual focusing or can be accessed independently.

ACCESS VIA THE FOCUS RING

Turning the focus ring will automatically enlarge a image section.

- Select **Focus Settings** in the main menu
- Select **Focus Aid**
- Select **Auto Magnification**
- Select **On**
- Turn the focus ring
 - An enlarged image section appears. The position of the enlargement depends on the position of the AF frame.
 - The rectangle within the frame at the top right represents the current magnification, as well as its position in the displayed cropped section.

Adjusting the enlargement function

- Turn the thumbwheel/right dial
 - The image section toggles between magnification factors.

Changing the position of the enlarged section

- Move the position of an enlarged cropped section by swiping
- or
- Press the joystick in the relevant direction

Exiting the enlargement function

- Tap the shutter button

Notes

- The enlargement will automatically return to normal viewing size about 5 s after the last movement of the focus ring.
- The most recently magnification function will still be active the next time the feature is accessed.

ACCESS VIA THE FUNCTION BUTTON

You can access the enlargement function independent of focusing for a better assessment of the settings.

The **Magnification** function must be assigned to one of the function buttons to use this feature (see p. 74).

Factory setting: Function button at the front (top)

Assigning a function to a function button

→ See p. 74

Accessing the enlargement function

→ Press the function button

- An enlarged image section appears. The position of the enlargement depends on the position of the AF frame.
- The rectangle within the frame at the top right represents the current magnification, as well as its position in the displayed cropped section.

Adjusting the enlargement function

→ Turn the thumbwheel/right dial

- The image section toggles between magnification factors.

Changing the position of the enlarged section

→ Move the position of an enlarged cropped section by swiping

or

→ Press the joystick in the relevant direction

Exiting the enlargement function

→ Tap the shutter button

Note

- The enlargement function remains active until it is exited.

DISTANCE DISPLAY

Distance information is shown in the top display during manual focusing.

- Focus Mode MF: when the shutter button is pressed to the first pressure point
- Focus Mode AF: when the shutter button is pressed and held at the first pressure point, followed by a turning of the focus ring

The unit of measure (**m** or **ft**) can be selected, see p. 83.

Note

- The focus distance is estimated based on the focus position transmitted by the lens.

USING AUTOFOCUS IN MF MODE

The joystick can be used as needed for automatic focusing. The AF modes AFs and AFc are available. You can also concurrently carry out exposure metering and save the resulting value (see p.151).

- Select **Customize Control** in the main menu
- Select **Joystick**
- Select **MF Mode**
- Select the desired setting
(AFs, AFs + AE-L, AFc, AFc + AE-L)

The metering functions are distributed as follows while the joystick is pressed and held:

| Menu settings | Joystick | Shutter button |
|--------------------------|--------------------|----------------|
| AFs + AE-L AFc + AE-L | Exposure and focus | – |
| AFs AFc | Sharpness | Exposure |

- Aim at the object
- Press and hold the joystick
 - The measurement is taken and saved.
- Store more measurements via the shutter button as needed
- Select the final image section
- Shutter release

ISO SENSITIVITY

The ISO setting covers a range between ISO 50 and ISO 200 000, allowing you to adapt to the relevant situation as required.

There is more leeway for the use of preferred shutter-speed/aperture combinations when choosing an automatic ISO setting. You can set priorities within the scope of the automatic setting, e.g. for reasons of pictorial composition.

Factory setting: **Auto ISO**

FIXED ISO VALUES

Values between ISO 50 and ISO 200000 can be selected in 37 increments. Manual ISO settings are initially done in 1/3 EV steps.

Via the Control Center

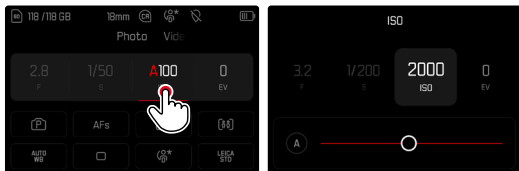

Note

- When high ISO values are used or the image is edited later, image noise, as well as vertical and horizontal stripes may become visible, particularly in larger, evenly lit areas of the object.

Using the dial

This function can be assigned to a setting dial.
Factory setting: Left Dial

Assigning a function to a setting dial

→ See p. 74

Selecting a permanent value

- Tap and hold the shutter button
- Turn the dial to the desired value
 - Set values are shown at the bottom left of the LCD panel.



AUTOMATIC SETTING

The camera automatically adjusts the sensitivity to ambient brightness and/or to the configured shutter-speed/aperture combination. In conjunction with aperture-priority mode, this function extends the range for automatic exposure control. The automatic setting of ISO sensitivity occurs in increments of 1 EV, 1/2 EV, 1/3 EV, or 1/6 EV depending on the selected setting.

→ Select **A**

Via the Control Center

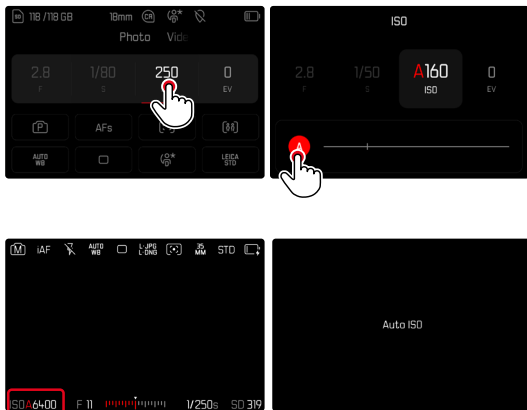

LIMITING SETTING RANGES

A max. ISO value can be set, which will then limit the automatic setting (**Maximum ISO**). A max. exposure time can also optionally be configured. There are automatic settings and fixed max. shutter speeds **1/2**s and **1/2000**s available for that purpose.

Separate settings are available for flash photography.

LIMITING ISO VALUES

All values from ISO 200 are available.

Factory setting: **6400**

- Select **ISO Settings** in the main menu
- Select **Auto ISO Settings**
- Select **Maximum ISO**
- Select the desired value

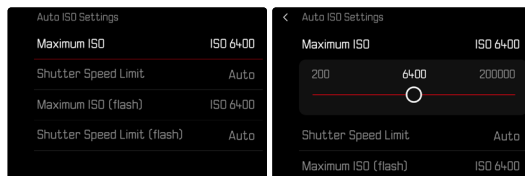

LIMITING SHUTTER SPEED RANGES

Factory setting: **Auto**

- Select **ISO Settings** in the main menu
- Select **Auto ISO Settings**
- Select **Shutter Speed Limit**
- Select the desired value

Note

- When set to **Auto**, the shutter speed is selected automatically based on the sensor format:
 - 35 mm: approx. $1/(2 \times \text{focal length})$
 - APS-C: approx. $1/(3 \times \text{focal length})$

The actual shutter speed used similarly depends on the **ISO Increment**.

DYNAMIC ISO SETTING

The thumbwheel can be configured to allow manual ISO settings in real time (see p. 75). The settings will cycle through all values available in the **ISO** menu. That means that **Auto ISO** can also be selected.

LIMITING ISO VALUES (FLASH)

All values from ISO 200 are available.

Factory setting: **6400**

- Select **ISO Settings** in the main menu
- Select **Auto ISO Settings**
- Select **Maximum ISO (Flash)**
- Select the desired value

LIMITING SHUTTER SPEED RANGES (FLASH)

Factory setting: **Auto**

- Select **ISO Settings** in the main menu
- Select **Auto ISO Settings**
- Select **Shutter Speed Limit (Flash)**
- Select the desired value

FLOATING ISO

This function complements Auto ISO. Light strength changes with many zoom lenses when the focal length is changed. Floating ISO will in this situation adjust the sensitivity in fine graduations and will simultaneously ensure that the selected settings of aperture value and shutter speed remain constant in (semi) automatic exposure modes. This will specifically in video shootings prevent visible jumps in brightness.

Factory setting: **On**

→ Select **ISO Settings** in the main menu

→ Select **Floating ISO**

→ Select **On**

Note

- **Floating ISO** can work only if the original ISO setting allows scope for change, i.e. the highest/lowest ISO setting is not already being used. The **Floating ISO** warning icon will be displayed in that case.

WHITE BALANCE

In digital photography, White Balance ensures neutral color rendering in any light. White Balance relies on the setting made in the camera, which light color is to be rendered as 'white'.

Four methods are available:





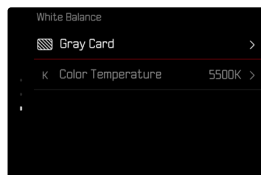
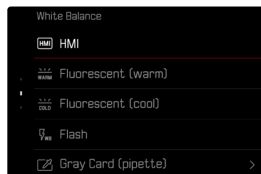
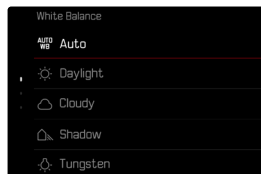



- automatic control
- fixed presets
- manual setting via metering
- direct setting of the color temperature

Factory setting: **Auto**



AUTOMATIC CONTROL/FIXED SETTINGS



- **Auto**: for automatic control, which delivers neutral results in most situations
- Various fixed presets for most frequently encountered light sources:

| | |
|--|---|
|  Daylight | For outdoor shootings in sunlight |
|  Cloudy | For outdoor shootings in cloudy conditions |
|  Shadow | For outdoor shootings with the main subject in shadow |
|  Tungsten | For indoor shootings with (predominantly) incandescent lamp light |
|  HMI | For indoor shootings with (predominantly) light from metal halide lamps |
|  Fluorescent (warm) | For indoor shootings with (prevailing) light from fluorescent tubes with warm light color |
|  Fluorescent (cool) | For indoor shootings with (prevailing) light from fluorescent tubes with cool light color |
|  Flash | For flash photography |

- > Select **White Balance** in the main menu
- > Select the desired setting

MANUAL SETTING VIA METERING

 **Gray Card** /  **Gray Card (pipette)**

This metering variant captures all color hues in the metering field and uses these to calculate a mean gray value. The variant  **Gray card** is suited best for subjects in which you can clearly identify a neutral gray or pure white area. If that is not the case, or should you wish to base your metering on an off-center detail, then  **Gray Card (pipette)** will be a better choice.

Note

- A value configured using this method will remain unchanged (i.e. it will be used for all subsequent photographs) until new measurements are taken or one of the other white balance settings is selected.

GRAY CARD (PIPETTE)

This metering variant captures only the color hue metered within the metering field and calculates the mean gray value from it.

- Select **White Balance** in the main menu
- Select **Gray Card (pipette)**
 - The following appears on the LCD panel:
 - the image based on automatic white balance
 - a cross in the middle of the image

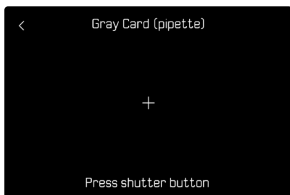

- Aim the metering field at a white or neutral gray area

Repositioning the focus frame

- Press the joystick in the relevant direction

Performing measurement

- Shutter release

or

- Press the joystick/thumbwheel
 - The measurement is taken.

Cancelling measurements

- Press the **FN** button

GRAY CARD

This metering variant captures all color hues in the metering field and uses these to calculate a mean gray value.

- Select **White Balance** in the main menu
- Select **Gray Card**
 - The following appears on the LCD panel:
 - the image based on automatic white balance
 - a frame in the center of the image

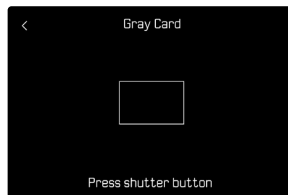

- Aim the metering field at a white or neutral gray area
 - The screen image changes dynamically in line with the reference area in the frame.

Performing measurement

- Shutter release

or

- Press the joystick/thumbwheel
 - The measurement is taken.

Cancelling measurements

- Press the **FN** button

DIRECT SETTING OF THE COLOR TEMPERATURE

Values between 2000 and 11500 K (Kelvin) can be set directly. That gives you a very wide range, which covers virtually all color temperatures occurring in real life and within which you can adapt color rendering to any light color and your personal preferences with incredible detail.

Factory setting: **5500 K**

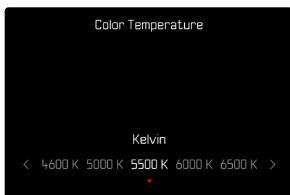

- Select **White Balance** in the main menu
- Select **Color Temperature**
- Select the desired value

EXPOSURE

The exposure setting is done dynamically via the two dials. As a rule, the thumbwheel controls the aperture and the right dial the shutter speed. The “free” dial is used for quick access to exposure compensation during semi automatic exposure setting. Function assignments can be modified, see p. 75.

Exposure settings can be done quickly and easily via the Control Center.

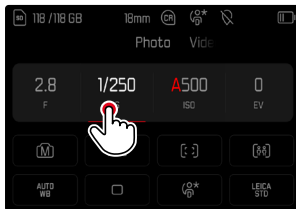

- Tap the desired control panel
 - The active control panel is highlighted in red.
 - A setting band appears instead of the light balance. A dot marks the current setting. The current setting value is displayed above the dot.
- Tap the setting band briefly in the desired position, or drag the dot to the desired position

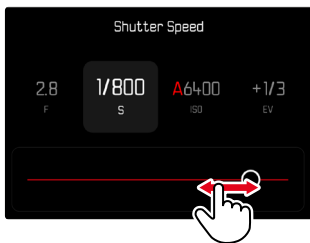

SHUTTER TYPE

The Leica SL3-P comes equipped with a mechanical shutter and a purely electronic shutter function. The electronic shutter expands the available shutter area and functions completely noiseless, which may be important in some work environments.

Factory setting: **Hybrid**

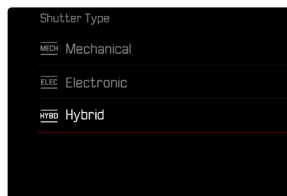

- Select **Shutter Type** in the main menu
- Select the desired setting (**Mechanical**, **Electronic**, **Hybrid**)

| | |
|-------------------|---|
| Mechanical | Only the mechanical shutter is used. Working range: 60 min to 1/8000 s. |
| Electronic | Only the electronic shutter function is used. Working range: 60 s to 1/16000 s. |
| Hybrid | You can add the electronic shutter function if you need faster shutter speeds than can be achieved with the mechanical shutter. Working range: 60 min to 1/8000 s + 1/8000 s to 1/16000 s. |

USE

The classic shutter sound of the mechanical shutter conveys an auditory feedback. It is well suited for long-term exposures, as well as for shots of moving objects.

The electronic shutter function allows photography with an open aperture in very bright due to very fast shutter speeds. The distinctive “rolling shutter” effect makes it less suitable for moving objects.





Notes

- The electronic shutter function does not allow flash photography.
- The electronic shutter function in combination with fast shutter speeds can result in stripe effects on the images when used with LED or fluorescent tube lighting.

EXPOSURE METERING METHODS

The following exposure metering methods are selectable.

Factory setting: **Multi-Field**

-  Spot
-  Center-weighted
-  Highlight-Weighted
-  Multi-field

- Select **Exposure Metering** in the main menu
- Select the desired metering method (**Spot**, **Center-Weighted**, **Highlight-Weighted**, **Multi-Field**)
 - The selected metering method is displayed in the header line of the screen image.

Spot metering allows a shifting of the focus point.

- Press the joystick in the relevant direction

Notes

- The exposure information (ISO value, aperture, shutter speed and light balance with exposure compensation scale) will help to determine the settings required for correct exposure.
- The most important displays (ISO value, aperture and shutter speed) will also appear in the top display.

SPOT

This metering method is concentrated exclusively on a small area in the center of the image. The metering fields are joined together when the exposure metering method **Spot** is combined with the AF metering methods **Spot** and **Field**. Exposure metering will then occur at the point specified by the AF frame, even if it is moved.

CENTER-WEIGHTED

This method considers the entire image field. The subject elements captured in the center will, however, impact on the calculation of the exposure value more so than areas around the edges.

MULTI-FIELD

This metering method is based on the detection of multiple values. These values are used in an algorithm to calculate an exposure value appropriate for a good rendering of the assumed main subject.

HIGHLIGHT-WEIGHTED

This method considers the entire image field. The exposure value will, however, be adjusted to very bright subject elements. That prevents the overexposure of bright subject elements without having to measure them individually. This metering method is particularly useful for objects that are significantly more brightly lit than the rest of the image (e.g. people in a spotlight), or that reflect the light significantly (e.g. white clothing).

| Multi-field | Highlight-weighted |
|---|--|
|  |  |
|  |  |
|  |  |

EXPOSURE MODES

There are four exposure modes available to adjust the rendering of the object or to create the desired pictorial composition:

- Program AE mode (**P**)
- Aperture-priority mode (**A**)
- Shutter-priority mode (**S**)
- Manual setting (**M**)

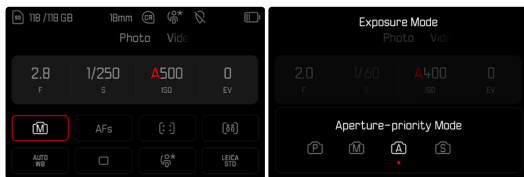

SELECTING A MODE

Via the thumbwheel

- Press the thumbwheel
 - The currently selected mode is shown in the top display. The currently selected mode is marked in red on screen.
- Turn the thumbwheel to select the desired mode
 - The mode display changes in the top display and on screen. All modes can be reached by turning the wheel in either direction.
 - The selected mode will be applied automatically approx. 2 s after the thumbwheel is moved the last time.



Applying the selected mode immediately

→ Press the joystick/thumbwheel

or

→ Tap the shutter button

Via the Control Center

→ Tap the control panel

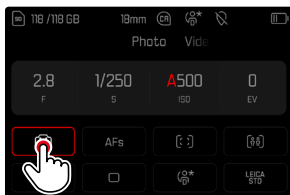

→ Tap the desired exposure mode

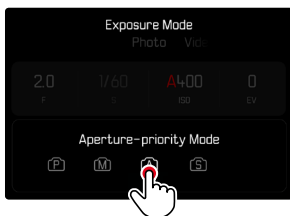

In shooting mode

→ Tap the control panel in the top info bar



→ Tap the desired exposure mode

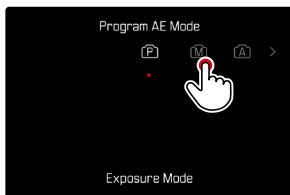

Note

- When using a lens with an aperture ring (e.g. Leica M lenses), only the exposure modes **A** (aperture-priority) and **M** (manual setting) will be available. Where that is the case, **F0.0** is displayed as the aperture value.

FULLY AUTOMATIC EXPOSURE SETTING – P CHANGING THE PRESET SHUTTER SPEED AND APERTURE COMBINATIONS (SHIFT)

PROGRAM AE MODE – P

The program AE mode facilitates fast and fully automatic photography. The exposure is controlled by an automatic shutter speed and aperture setting.

- Select the operating mode **P** (see p. 143)
 - Tap and hold the shutter button
 - Exposure information is displayed at the bottom of the screen. This contains the automatically set value pair of aperture setting and shutter speed.
 - All other visible displays of the info bars will be hidden.
 - Shutter release
- or
- Adjusting the automatically set value pair (Program shift)

Changing the preset values using the Shift function combines the reliability and speed of fully automatic exposure control with the opportunity to vary the speed/aperture combination selected by the camera at any time to fit in with your own ideas and intentions. The overall exposure, i.e. the brightness of the image, remains unchanged. Faster shutter speeds are a good choice for e.g. sports pictures, while longer speeds will offer more depth of field for e.g. landscape pictures.

- Turn the thumbwheel to the left/right (right = greater depth of field with slower shutter speeds, left = faster shutter speeds with lesser depth of field)
 - Shifted value pairs are marked with an asterisk next to the . The icon in the top display changes from **P** to **Ps**.

Note

- The adjustment range is limited to guarantee correct exposure.

SEMI-AUTOMATIC EXPOSURE SETTING

– A/S

APERTURE-PRIORITY MODE- A

Aperture-priority mode sets the exposure automatically according to the manually selected aperture. This mode is suitable for shots in which the depth of field is a critical compositional element.

A correspondingly small aperture value will allow you to shrink the depth of field range. This can be helpful when e.g. offsetting the highly focused face in a portrait against an unimportant or distracting background. Conversely, you can use a higher aperture value to increase the depth of field range, so that everything from the foreground to the background will be in full focus in a landscape shot.

- Select the operating mode **A** (see p. 143)
- Set the desired aperture value
- Tap and hold the shutter button
 - Exposure information is displayed at the bottom of the screen. This contains the automatically set value pair of aperture setting and shutter speed.
 - All other visible displays of the info bars will be hidden.
- Shutter release

Note

- The remaining exposure time after shutter release is counted down in seconds on the display for shutter speeds greater than 2 s.

SHUTTER-PRIORITY MODE – S

Shutter-priority mode will set exposure automatically according to the manually selected shutter speed. It is therefore particularly suitable for pictures of moving objects, where the sharpness of the movement depicted is a critical picture composition element.

An appropriately fast shutter speed can help to avoid e.g. unwanted motion blurring and will “freeze” the object. Conversely, an appropriately longer shutter speed can help create a better feeling of motion in the image with targeted “tracer effects”.



- Select the operating mode **S** (see p. 143)
- Set the desired shutter speed
- Tap and hold the shutter button
 - Exposure information is displayed at the bottom of the screen. This contains the automatically set value pair of aperture setting and shutter speed.
 - All other visible displays of the info bars will be hidden.
- Shutter release

MANUAL EXPOSURE SETTING – M

The following manual settings for shutter speed and aperture are a good choice:

- to create a special image mood that can only be achieved with a very specific type of exposure
 - to ensure a perfectly identical exposure for multiple images with different cropped sections
- Select the operating mode **M** (see p. 143)
- Select desired exposure
- The exposure compensation is done using the scale of the light balance.
- Tap and hold the shutter button
- Exposure information is displayed at the bottom of the screen.
 - All other visible displays of the info bars will be hidden.
- Shutter release

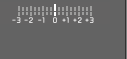
Displays on the light balance:

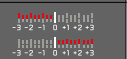
| | |
|---|--|
|  | Correct exposure |
|  | Underexposure or overexposure by the displayed value |
|  | Underexposure or overexposure by more than 3 EV (Exposure Value) |

Notes

- The screen image will show an exposure preview if **P-A-S-M** is selected in the menu item **Exposure Preview** (after exposure metering, see p. 150).
- The shutter-speed dial must be clicked to one of the engraved exposure shutter speeds.

LONG-TERM EXPOSURE

FIXED SHUTTER SPEEDS

Your Leica SL3-P allows shutter speeds up to 2 minutes in modes **S** and **M** (depending on the selected ISO setting). The remaining exposure time after shutter release is counted down in seconds on the display for shutter speeds greater than 1 s.

Via the Control Center

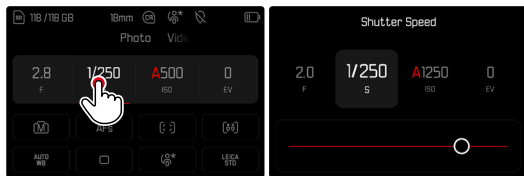

- Select the operating mode **M** (see p.143)
- Select the desired shutter speed
(Must be done via fine tuning of the shutter speed, see p.143)
- Shutter release

Using the dial

Factory setting: Right Dial

- Select the operating mode **M** (see p.143)
- Turn the right dial
- Select the desired shutter speed
- Shutter release

B FUNCTION

Using the **Bulb** setting in **M** mode will leave the shutter open as long as the shutter button remains pressed (max. 30 min; depending on ISO setting).

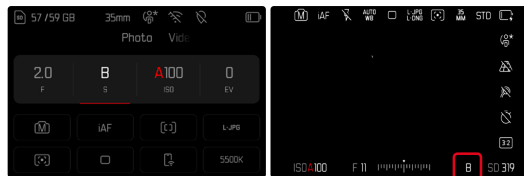

- Select the operating mode **M** (see p.143)
- Turn the right dial in clockwise direction until **B** is displayed as the shutter speed

Notes

- Image noise becomes more apparent when using higher sensitivities, particularly on uniform dark areas. Long exposure times may cause severe image noise. In order to reduce this annoying phenomenon, the camera will take a second “dark frame” (taken with the shutter closed) automatically after a shooting with slow shutter speed and high ISO value. The noise metered in this parallel shot will then be “subtracted” digitally from the data for the actual shot. In such cases the message **Noise reduction in progress...** will appear with a relevant time value. This “exposure time” doubling must be taken into account in long-term exposures. The camera must not be switched off during that time. We recommend disabling Noise Reduction to allow shooting multiple frames in series and to apply noise reduction later during the post-editing stage. The images will have to be taken in raw data format.
- The maximum selectable shutter speed depends, among other things, on the setting of the menu item **Shutter Type**, see p. 140.

NOISE REDUCTION

Image noise becomes more apparent when using higher sensitivities, particularly on uniform dark areas. Long exposure times may cause severe image noise. In order to reduce this annoying phenomenon, the camera will take a second “dark frame” (taken with the shutter closed) automatically after a shooting with slow shutter speed and high ISO value. The noise metered in this parallel shot will then be “subtracted” digitally from the data for the actual shot. In such cases the message **Noise reduction in progress...** will appear with a relevant time value.

This “exposure time” doubling must be taken into account in long-term exposures. The camera must not be switched off during that time. We recommend disabling Noise Reduction to allow shooting multiple frames in series and to apply noise reduction later during the post-editing stage. The images will have to be taken in raw data format.

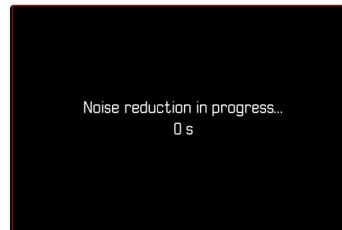

Under certain conditions, noise reduction will always be active as long as the function is enabled. That includes shots taken with the T function, as well as long-term exposure frames with shutter speeds of $\geq +8$ s.

In all other cases, noise reduction depends on a combination of factors (specifically ISO setting, exposure time, and sensor temperature). The following table contains a list of shutter speeds typical for a sensor temperature of 25°C, at which noise reduction would be applied.

| ISO | Shutter speed longer than |
|----------------|---------------------------|
| 100 | 7 s |
| 200 | 6.4 s |
| 400 | 5.9 s |
| 800 | 5.4 s |
| 1600 | 4.9 s |
| 3200 | 4.5 s |
| 6400 | 4.2 s |
| $\geq 12\,500$ | 3.8 s |

Noise Reduction can be optionally deactivated (see p. 94).

EXPOSURE CONTROL

EXPOSURE PREVIEW

The brightness of the screen image mirrors the effects of the selected exposure settings when pressing and holding the shutter button on the first pressure point. That allows an assessment the effect of the relevant exposure setting on the image before taking the photo. This will apply as long as the subject brightness and the set exposure don't result in excessively low or high brightness values.

This function can be disabled for the manual exposure setting (**M**).

Factory setting: **P-A-S-M**

→ Select **Live View Settings** in the main menu

→ Select **Exposure Preview**

→ Select **P-A-S** (only in program AE, aperture-priority AE and shutter-priority AE mode) or **P-A-S-M** (also for manual setting)

Notes

- Depending on ambient lighting conditions, the brightness of the screen image may differ from that of the actual images, despite the settings described above. The screen image will appear considerably darker than the – correctly exposed – picture. That is particularly the case in long-term exposures.
- The exposure preview will also be displayed if exposure metering is done via another control element (e.g. using the joystick, provided it was assigned the **AE-L** function).

EXPOSURE LOCK

We often want to arrange important subject elements outside the center of the image for reasons of pictorial composition and these elements may sometimes be very bright or very dark. Center-weighted metering and spot metering, however, mainly capture an area in the center of the image and are calibrated to an average gray scale value.

In that case, the exposure lock initially allows a metering of the main subject, as well as storing of the relevant settings until the final image section is set. The same applies for focusing (AF-L) in any autofocus mode.

Usually both lock functions (focusing and exposure) are done at the same time with the shutter button. Additionally, you can divide the memory functions between the shutter button and the function button, or assign both to a function button.

The functions include settings and storage.

AE-L (AUTO EXPOSURE LOCK)

The camera stores the exposure value. The focus can therefore be set on another object, no matter which exposure value is selected.

AF-L (AUTO FOCUS LOCK)

The camera stores the focus setting. That makes it easier to change the image section when focusing is fixed.

AE-L/AF-L

With this option enabled, the camera stores the exposure value and the focus setting when the assigned button is pressed and held.

Notes

- An exposure lock doesn't make much sense in conjunction with multi-field metering, because a targeted capture of an individual object element will not be possible.
- Any previously set exposure lock will be removed by a manual setting of the aperture ring or the shutter-speed dial.

EXPOSURE LOCK IN AF MODE

The metering functions are distributed as follows while the joystick is pressed and held:

| Menu settings | Joystick | Shutter button |
|---------------|--------------------|----------------|
| AF-L + AE-L | Exposure and focus | No function |
| AF-L | Sharpness | Exposure |
| AE-L | Exposure | Sharpness |
| AF-ON | Sharpness | No function |

The shutter button will store both measured values if the joystick is not pressed.

Via the shutter button

- Aim at the key part of the object or at a similar detail
- Tap and hold the shutter button
 - The measurement is taken and saved.
- Pan the camera to capture the final image section while keeping the shutter button pressed
- Shutter release

Via the Joystick

- Select **Customize Control** in the main menu
- Select **Joystick**
- Select **AF Mode**
- Select the desired setting
- Press and hold the joystick
 - The measurement is taken and saved.
- Store more measurements via the shutter button as needed
- Select the final image section
- Shutter release

EXPOSURE LOCK IN MF MODE

In MF mode, only the exposure can be locked via the shutter button. This function can also be assigned to the joystick.

The exposure value is saved via the shutter button independent of the setting if the joystick is not pressed.

Via the shutter button

- Aim at the key part of the object or at a similar detail
- Tap and hold the shutter button
 - The measurement is taken and saved.
- Select the final image section
- Shutter release

Via the Joystick

- Select **Customize Control** in the main menu
- Select **Joystick**
- Select **MF Mode**
- Select **AE-L**
- Press and hold the joystick
 - The measurement is taken and saved.
- Select the final image section
- Shutter release

EXPOSURE COMPENSATION

Exposure meters are calibrated for a medium gray scale value, which matches a standard, i.e. average image object. Should the measured image detail not fulfill that requirement, then the a relevant exposure compensation can be effected.

Specifically where several shots are taken in sequence, for example if for a series a slightly lesser or greater exposure is desired for a particular reason, then exposure compensation can be a very useful function: Unlike with exposure lock, the setting remains active until it is reset. Exposure compensation values can be set in the range ± 3 EV in $1/3$ EV increments (EV: Exposure Value).

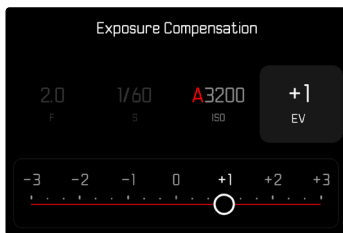

A Set compensation value (marks at 0 = Off)

Using dial controls

This function is assigned to one of the dials in the three (semi) automatic exposure modes, making it easily accessible.

Factory setting: Right Dial

- Select **Customize Control** in the main menu
- Select **Dials**
- Select **Dials (AF lenses)** or **Dials (MF lenses)** depending on the lens used.
- Selecting the desired dial
- Select **Exposure Compensation**
- Use the assigned setting dial to set the desired value

Via the Control Center

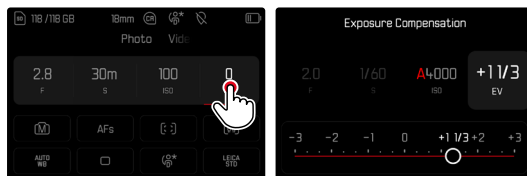

Notes

- While setting the value, you can see the effect on the screen image, which becomes darker or lighter.
- The following applies for set compensation values, no matter how they were initially set: They remain effective until they are manually reset to 0, even if the camera is switched off and on again in the meantime.
- The set exposure compensation is indicated by a mark on the exposure compensation scale in the footer line.
- Changes to the **EV Increment** setting lead to the cancellation of a compensation that has been set, i.e. in such cases it is automatically reset to 0.

DEPTH OF FIELD CHECK

This function simulates the effects of the current aperture and shutter speed settings. It allows the user to assess the exposure and depth of field of the image before shooting. The function is similar to that of the depth-of-field preview button.

- Assigning the function **Exposure/DOF Simulation** to a function button
- Press the function button
 - The display cycles through the display options.



– No preview



– Preview for the current aperture value (depth of field)



– Preview for the current aperture value (depth of field) and the current shutter speed (exposure preview)

When the exposure information is visible, a green eye symbol  next to the values for aperture and shutter speed will display the active depth of field/exposure preview. The relevant unit of measure icon will additionally appear in green.

SHOOTING MODES

CONTINUOUS SHOOTING

The camera is set to single shots by default (**Single**). Series of shots can also be created to e.g. capture motion sequences at various stages.

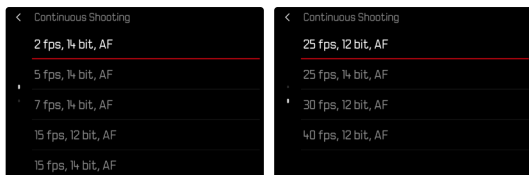

- Select **Drive Mode** in the main menu
- Select **Continuous Shooting**
- Select the desired setting

Once you have finalized your settings, the camera will do continuous shootings as long as you keep the shutter button pressed down fully (and you have sufficient space on your memory card, see “Technical Data”).

Notes

- Continuous shooting modes at 12 bit provide a significantly shorter sensor readout time, which reduces the rolling shutter effect.
- In continuous shooting mode, the shutter delay is higher than in single shot mode and depends on e.g. frame rate and screen refresh rate. The camera begins capturing images as soon as the shutter button is tapped (S1) and saves them only when the button is fully pressed (S2) to reduce the delay at high frame rates (15 fps and higher). This may result in a short delay when tapping. Only Contrast AF can be used at large apertures.
- We recommend deactivating the preview mode (**Auto Review**) when using this function.
- Regardless of how many frames were taken in a series, the last image in the series or the last image saved on the memory card while the saving pro-

cess is ongoing will be displayed first in both review modes.

- Continuous shooting is not possible if a flash is used. Only a single shot will be taken if the flash function is activated.
- Continuous shooting mode is not available in combination with the self-timer function.
- The buffer memory of the camera only allows a limited number of frames in series and in the selected exposure frequency. The exposure frequency is reduced, once the capacity limit of the camera's buffer memory is reached. This slow-down is due to the time required to transfer the data from the buffer memory to the card. The remaining number of exposures is displayed at the bottom right.
- The following applies for continuous shooting with +2 fps to +6 fps:
Automatic settings (exposure settings in operating modes **P/A/S**, automatic white balance and autofocus) are implemented individually for each frame.
- The following applies for continuous shooting with 7 fps – 40 fps:
Automatic settings (exposure settings in operating modes **P/A/S**, automatic white balance and autofocus) are implemented for the first frame, and are then applied for each subsequent frame in the same picture series.

INTERVAL SHOOTING

This camera allows you to automatically capture motion sequences over extended periods of time using the interval shooting function. You specify the number of frames, the intervals between shots, and the start time of the series.

When applying exposure and focus settings, keep in mind that conditions may change during the course of the operation.

- Select **Drive Mode** in the main menu
- Select **Interval Shooting**
- Select **Settings**

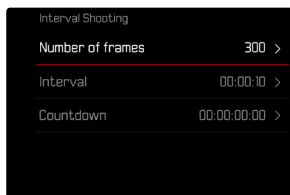

SPECIFYING THE NUMBER OF FRAMES

- Select **Number of Frames**
- Enter the desired value

SPECIFYING THE INTERVALS BETWEEN SHOTS

- Select **Interval**
- Enter the desired value

SETTING THE DELAY TIME

- Select **Countdown**
- Enter the desired value

Getting started

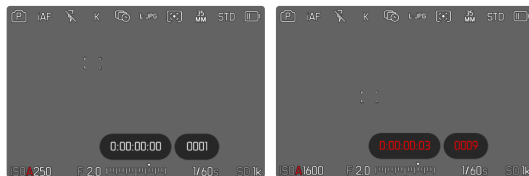

- Press the shutter button
 - The LCD panel will switch off automatically between recordings. Tapping the shutter button reactivates the LCD panel.
 - The remaining time until the next shoot and its number is displayed at the top right.

Cancelling a running series of shots

- Press the joystick
 - A small menu appears.
- Select **End**



Important

- A shooting interval longer than the exposure time must be selected. A minimum buffer of 1-2 seconds is recommended; with long exposure times, a larger buffer is required (e.g. 3-4 seconds). Where exposure time is set to be longer than the interval, the camera will shift the next frame automatically to the next interval.

Notes

- The use of autofocus in interval shooting may result in not all exposures having their focus on the same object.
 - The camera may switch off and on again if "Auto power off" is set and no other camera operation occurs between the individual shots.
 - Interval shooting over an extended period of time in a cold location or in a place with high temperature and humidity may result in malfunctions.
 - Interval shooting will be interrupted or canceled in the following situations:
 - if the battery is depleted
 - if the camera is switched offMake sure to check the battery for sufficient charge.
 - Interrupted or canceled interval shooting can be resumed by switching the camera off, replacing the battery or memory card as needed and then switching the camera back on. A prompt will be displayed on screen if the camera is switched off and on again while the **Interval Shooting** shooting function is active.
 - The interval function remains active after the shoot, and also after the camera is switched off and on again, until another shooting mode (Drive Mode) is set.
 - Availability of the interval function does not mean that the camera is suitable for use as a monitoring device.
 - Regardless of how many frames were taken in a series, the last image in the series or the last image saved on the memory card while the saving process is ongoing will be displayed first in both review modes.
 - The shots of an interval shooting are marked with  in review mode.
- The camera may under some circumstances be unable to take good pictures. That may happen if, for example, focusing was unsuccessful. In that case, the camera will not take a picture and the series will continue with the next interval. The message **Some Frames are dropped** appears on screen.

EXPOSURE BRACKETING

Many attractive objects are rich in contrast, which means they have very bright and very dark areas. The image effect can be dramatically different, depending on which of these areas you choose to align your exposure with. The automatic bracketing function in aperture-priority mode allows you to produce several alternatives with graduated exposure values and varying shutter speeds. You can then select the image you like best or use relevant photo editing software to calculate an image with a particularly broad contrast spectrum (HDR).

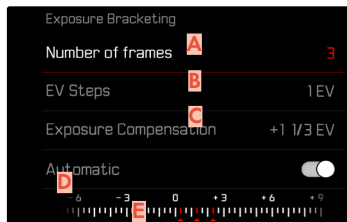

- A** Number of frames
- B** Exposure difference between shots
- C** Exposure compensation
- D** Light value scale
- E** Exposure values of the images marked in red
(The scale will be offset by the relevant value if exposure compensation is set concurrently.)

You can select the desired number of frames (3 or 5). The exposure difference, which can be set via **EV Steps**, can be up to 3 EV.

- Select **Drive Mode** in the main menu
- Select **Exposure Bracketing**
- Select **Settings**
- Select the desired number of frames under **Number of Frames** in the submenu
- Select the desired exposure offset under **EV Steps** in the submenu
- Select the desired **Exposure Compensation** value in the submenu
 - The marked exposure values change positions according to the settings selected. In the case of exposure compensation, the scale also shifts.
 - The selected exposure compensation value will be applied to the entire series of shots.
- Select the desired setting under **Automatic** in the submenu
 - With the factory setting in place (**On**), the entire exposure series will run after the shutter button is pressed once; when the setting is **Off**, each picture must be taken individually.
- Take one or several shots by pressing the shutter button

Notes

-  appears on the LCD panel if the bracketing function is activated. You can watch the effect of the function on screen during shooting (brighter or darker).
- Depending on the exposure mode, the exposure gradations are produced by changing the shutter speed and/or aperture value:
 - Shutter speed (**A/M**)
 - Aperture (**S**)
 - Shutter speed and aperture value (**P**)
- The sequence of shots: underexposure/correct exposure/overexposure.
- The working range for automatic bracketing may be limited depending on the available shutter speed/aperture combination.
- With automatic ISO sensitivity control enabled, the sensitivity calculated by the camera automatically for the raw files will also be applied to all other shots in the series, i.e. the ISO value will not change during bracketing. This may mean that the slowest shutter speed specified under **Shutter Speed Limit** is exceeded.
- The working range for automatic bracketing may be limited (depending on the originally set shutter speed). The specified numbers of frames will be taken regardless. Several shots in a series may consequently have the same exposure values.
- The function remains active until another function is selected from the **Drive Mode** submenu. If no other function is selected, another bracketing is taken each time the shutter button is pressed.

MULTISHOT

In multishot mode, up to 8 individual images are taken with a very small offset. To do so, the sensor is moved minimally between the individual shooting (by less than a pixel width). The individual frames are then merged into a single shot with extremely high resolution (176.7 MP) and a DNG image is additionally saved.

Multishot images are highly sensitive to camera shake. It is therefore recommended to mount the camera on a tripod.

→ Select **Drive Mode** in the main menu

→ Select **Multi-Shot**

Notes

- Additionally, the functions **Save One Single Shot** and **Motion Artefacts Correction** (in combination with Tripod mode) can be enabled.
- In some situations, e.g. small movement in foliage, some image artefacts may occur. Where that is the case, it may make sense to choose a different Multi-shot mode.
- Microsoft Windows may display a reduced image size. Specialized image editing software (e.g. by Capture One or Adobe) will display the correct size.

FINE TUNING

Various fine-tuning settings are available as part of the Multishot mode to ensure optimal results.

- Select **Drive Mode** in the main menu
- Select **Multi-Shot**
- Select **Settings**
 - The submenu appears.

SHOOTING MODE SELECTION

- Choose **Tripod** or **Handheld**

FILE FORMAT SELECTION

- Choose the desired Multishot file format
(**DNG**, **DNG + L-JPG**, **DNG + M-JPG**, **L-JPG (176 MP)**,
M-JPG (88 MP))

SELF-TIMER DELAY TIME SELECTION

- Choose the desired delay time
(**2 s**, **12 s**, **Off**)

SELF-TIMER

The self-timer function allows shoot with a preset time delay. We recommend that the camera is placed on a tripod.



- Select **Self-timer** in the main menu
- Select **Settings**
- Select the desired setting
(**Self-timer 2 s**, **Self-timer 6 s**, **Self-timer 12 s**, **Self-timer 30 s**)
- Shutter release
 - The remaining time until exposure is counted down on the LCD panel. The self-timer LED at the front of the camera counts down the delay time. It flashes slowly during the first 10 s, then fast for the last 2 s.
 - The self-timer delay time can be canceled at any time by taping the shutter button; the relevant settings remain intact.

Notes

- Exposure metering is done first; in autofocus mode, focusing is first. Only then will the delay time commence.
- The self-timer function is available only for single frame shooting and for bracketing.
- The function remains active until another function is selected from the **Self-timer** submenu.

SPECIAL SHOOTING MODES

PERSPECTIVE CONTROL

This assist function displays a frame showing the expected cropped section of the image after a correction of the perspective of vertical falling lines. Perspective Control helps to achieve a generally straighter vertical line and straight horizon, which ensures a natural image effect, specifically in architectural images.

The function “Perspective Control” calculates the image section and the required distortion correction based on the actual panning angles of the camera and the lens used. In effect, the camera orientation during shooting (determined by internal camera sensors) is the decisive factor and not the lines visible in the image object. The function is therefore unlike automatic perspective control features used for post-editing, which are generally based on the image content.

The functionality depends on the image file format used (JPG or DNG). For JPG format images, the correction occurs directly in the camera and the corrected image is stored. For DNG format images, the relevant information is written to the meta data of the original image. Image correction is done later on using a program like Adobe Photoshop Lightroom® or Adobe Photoshop®*.

Factory setting: Off

Notes

- In case of large panning angles, the distortion correction needed for a complete perspective control would be too extreme. That is why this function is automatically skipped or only partially used where angles are too large. In that case, we recommend creating DNG format images and effecting the desired corrections in a post-editing step.
- A histogram will not be available for technical reasons, while the function **Perspective Control** is active.

* See p. 139 for more information.

This function can only be used in Live View mode.

- You may have to activate Live View
- Select **Perspective Control** in the main menu
- Select **On**



ACTIVE PERSPECTIVE CONTROL



DETECTED PERSPECTIVE IN LIVE VIEW MODE



CORRECTED PERSPECTIVE IN REVIEW MODE



JPG FORMAT IMAGES

For JPG format images, the correction occurs directly in the camera and only the corrected image is stored. Any image content outside the frame will be lost.

DNG FORMAT IMAGES

In DNG format, the entire sensor image is stored unchanged. The data calculated by Perspective Control is written to the meta data of the image. Image correction is done later, using appropriate software like Adobe Photoshop Lightroom® or Adobe Photoshop®. A corrected preview version of the image (thumbnail) is displayed in review mode. The same applies for automatic review directly after the image is taken.

In contrast, the original image will usually appear when opening the file in Adobe Photoshop Lightroom® or Adobe Photoshop®. Depending on the default settings of the software, the image can also be directly displayed with the corrections from the auxiliary frame.

PERSPECTIVE CONTROL IN ADOBE LIGHTROOM® AND ADOBE PHOTOSHOP®

Perspective Control can be done as part of the post-editing process for DNG format images using e.g. Adobe Photoshop Lightroom® or Adobe Photoshop®. Read the Adobe Online Help for more detailed information about the topic.

ADOBE LIGHTROOM®:

<https://helpx.adobe.com/en/lightroom-classic/help/guided-upright-perspective-correction.html>

ADOBE PHOTOSHOP®:

<https://helpx.adobe.com/en/photoshop/using/perspective-warp.html>

CORRECTION AND DISPLAY OF AUXILIARY LINES

Select the function “With auxiliary lines” under “Geometry” > “Upright” to apply the correction defaults of the camera and display the auxiliary lines.

Correction will automatically applied if the RAW default setting “Camera Settings” is selected.

Correction can be disabled under “Upright” at any time.

<https://helpx.adobe.com/en/photoshop/kb/acr-raw-defaults.html>

→ Select “Camera Settings” as the RAW default setting

IMAGE OVERLAY

Leica SL3-P allows a transparent overlay over previous shots as an image composition tool. That way, objects can be recorded from the exact same position at different times, or various objects can be aligned exactly against the same background in multiple shooting sessions. The transparent overlay image will not be visible in the finished image.

One usage scenario would be the creation of an image series in front of a tree across an entire year. The precise alignment of the image would also allow the creation of a time lapse shooting.



- Select **Capture Assistants** in the main menu
- Select **Image Overlay**
- Select **Settings**

TRANSPARENCY

The transparency of the overlay image can be adjusted in line with e.g. lighting conditions.

- Select **Transparency**
- Select **High/Low**

IMAGE SELECTION

Any image from the memory card can be selected for the image overlay.

- Select **Choose Overlay Image**
 - The Image Selection display appears.



- In Image Selection view, all recorded images appear in full screen mode. An overview of all images in thumbnail size is not available. The info displays can be accessed as before.

Note

- It may not be possible to render files with this camera that were not recorded with this device. The same applies to the Overlay function.

Browsing through the images

→ Press the joystick left/right

or

→ Turn the thumbwheel

or

→ Swipe to the left or right

Selecting a recorded image

→ Press the joystick/thumbwheel

or

→ Directly select the control element “Confirm”

Resetting the function when switching off the camera

The function settings can optionally be reset when switching off the camera.

→ Select **Image Overlay** in the main menu

→ Select **Reset on Turn Off**

→ Select **On**

- The image selection and the setting for **Use Image Overlay** will remain intact after the camera is switched off if **Off** is selected.

ACTIVATING THE FUNCTION

→ Select **Image Overlay** in the main menu

→ Select **Use Image Overlay**

→ Select **On**

FLASH PHOTOGRAPHY

The camera determines the necessary flash intensity by firing one or more pre-flashes before taking the actual photo. The main flash fires immediately after, i.e. during exposure. All factors influencing exposure (e.g. filters, aperture settings, distance to the main subject, reflective ceilings, etc.) are automatically considered.

COMPATIBLE FLASH UNITS

The full functional scope described in this instruction manual, including TTL flash exposure is available only in conjunction with Leica system flash units like the SF 40, or devices by Profoto. Other flash units, which only have a positive center contact, can be safely fired via the Leica SL3-P, but cannot be controlled via the camera. Correct function cannot be guaranteed when using any other flash unit.

Important

- The use of incompatible flash units with your Leica SL3-P may result in irreparable damage to the camera and/or the flash unit.

Notes

- When using flash units that are not specifically designed for the camera and can therefore not automatically switch over the white balance of the camera should be used in the **WB** flash setting.
- A flash unit that is not ready to flash may cause incorrect exposures or error messages.
- Studio flash systems may have a very long flash firing duration. It may therefore be advantageous to select a slower shutter speed than 1/200 s when using such a system. The same applies for RF-controlled flash firing for so-called “off-camera” flashes, as the transmission time may cause a delay.
- Continuous shooting and automatic bracketing with flash are not available.
- Use a tripod to prevent blurring at slow shutter speeds. Alternatively, you can select a higher sensitivity.

ATTACHING THE FLASH UNIT

- Switch off the camera and flash unit
- Pull off the accessory shoe cover and store it in a safe place
- Slide the foot of the flash unit all the way into the accessory shoe and use the clamping nut (where available) to secure it against accidental movement
 - Movement inside the accessory shoe can interrupt required contacts and therefore cause malfunctions.

DETACHING THE FLASH UNIT

- Switch off the camera and flash unit
- Release the lock as needed
- Detach the flash unit
- Replace the accessory shoe cover

Note

- Make sure that the accessory shoe cover is always in place when no accessory is attached (e.g. a flash unit).

FLASH EXPOSURE METERING (TTL METERING)

The camera-controlled, fully automatic flash mode is available in this camera in conjunction with system-compatible flash units (see p. 166), and in both exposure modes (Aperture-priority Mode and Manual).

In aperture-priority mode and with manual setting, the camera furthermore allows the use of other interesting flash techniques like flash synchronization and firing with slower shutter speeds than the max. sync time.

The camera additionally communicates the sensitivity setting to the flash unit. The flash unit can use this information to automatically adjust its range data, provided the device comes with these displays and the aperture setting selected on the lens is also entered manually on the flash unit. The ISO sensitivity setting cannot be altered via the flash unit on system-compatible units, because the information is received from the camera.

SETTINGS ON THE FLASH UNIT

| Operating mode | |
|----------------|---|
| TTL | Automatic control by the camera |
| A | SF 40, SF 60: Automatic camera control, no flash exposure compensation SF 58, SF 64: Control via the flash unit using a built-in exposure sensor |
| M | The flash exposure must be set to an output level to match the aperture and shutter speed settings determined by the camera. |

Notes

- Set the flash unit to **TTL** mode to allow automatic control of the unit by the camera.
- When set to **A**, objects with above or below average brightness may not be exposed correctly.
- Please read the relevant manual provided with third party flash units regarding their various operating modes.

FLASH MODES

Select one of the three available operating modes.

- Automatic
- Manual
- Long-term exposure

AUTOMATIC FLASH ACTIVATION

That is the default flash mode. The flash unit will fire automatically if poor lighting conditions would mean slower shutter speeds, which could result in blurred images.

MANUAL FLASH ACTIVATION

This mode is suitable for backlit pictures in which the main subject does not fill the entire frame and is in shadow, or in situations where a fill-in flash will moderate sharp contrasts (e.g. in direct sunlight). The flash will fire each time a picture is taken, regardless of prevailing lighting conditions. The flash intensity depends on the metered ambient brightness: in poor light it is the same output as in automatic mode, with output decreasing with increasing brightness. The flash will then work as a fill-in light, e.g. to light up dark shadows in the foreground or backlit objects, and to create more balanced overall lighting.

⚡Ⓜ AUTOMATIC FLASH ACTIVATION AT SLOWER SHUTTER SPEEDS (LONG-TERM SYNCHRONIZATION)

This mode ensures appropriately exposed, brighter dark backgrounds and bright foreground.

The shutter speed is not extended beyond 1/30s in the other flash modes to minimize the risk of blurring. This may mean, however, that pictures with flash exposure can end up with objects in the background not illuminated by the flash and therefore being underexposed. In this mode, slower shutter speeds (up to 30s) are permitted to avoid this effect.

- Select **Flash Settings** in the main menu
- Select **Flash Mode**
- Select the desired setting
 - The currently active mode is displayed on screen.



FLASH CONTROL

The settings and functions described in the following sections only apply to settings and functions available in this camera and in system-compatible flash units.

SYNC POINT

Flash exposures are lit by two light sources:

- existing light from the environment
- the additional flash

Any subject elements lit primarily by the flash will almost always be rendered in perfect focus by the short burst of light, provided the focus is set correctly. All other subject elements in the same frame lit by ambient light or lit from within will be rendered with varying degrees of sharpness. Whether or not these object elements will be rendered in sharp focus or blurred, as well as the degree of “blurriness” depends on two interdependent factors:

- the shutter speeds
- the speed of movement of the subject elements or camera during shooting

The longer the shutter speed and the faster the motion, the greater the difference between the two superimposed partial images.

A flash is usually fired at the start of exposure (**Start of Exposure**). This may result in apparent contradictions, e.g. the image of a vehicle being overtaken by its own light trail. This camera alternatively allows synching with the end of exposure (**End of Exposure**). The sharp image will in this case be a rendering of the end of the captured motion. This flash technique creates a more natural impression of movement and dynamics in the image.

This function is available with all camera and flash unit settings.

Factory setting: **End**

- Select **Flash Settings** in the main menu
- Select **Flash Sync**
- Select the desired setting (**Start**, **End**)
 - The set sync point is shown in the header line.

Notes

- Do not use sync cables that are longer than 3 m.
- When using the flash with faster shutter speeds, a difference between the two flash firing points will be barely discernible or only noticeable for very fast movements.

FLASH RANGE

The usable flash range depends on the aperture and sensitivity values set manually or calculated by the camera. It is important to ensure that the subject is within the relevant flash range for sufficient illumination. A permanent setting to the shortest available shutter speed for flash mode (sync time) may often result in unnecessary underexposure of those subject elements that are not lit sufficiently by the flash.

This camera allows the fine tuning of the shutter speed used in flash mode in combination with aperture-priority mode depending on the conditions of the object or your own pictorial composition ideas.

Factory setting: **Auto**

- Select **ISO Settings** in the main menu
- Select **Auto ISO Settings**
- Select **Shutter Speed Limit (Flash)**
- Select the desired value

Note

- The menu item **Shutter Speed Limit (Flash)** in submenu **Flash Settings** is identical to the menu item of the same name in submenu **Auto ISO Settings**. A setting in one menu will affect the other.

FLASH EXPOSURE COMPENSATION

This function can be used to selectively reduce or enhance flash exposure regardless of ambient light, e.g. to brighten the face of a person in the foreground when taking a photo outdoors in the evening while retaining the same general lighting mood.

Factory setting: **0 EV**

- Select **Flash Settings** in the main menu
- Select **Flash Exp. Compensation**
 - The submenu displays a scale with a red setting mark. The function is deactivated if the value is set to **0**.
- Set the value on the scale
 - The set value is displayed above the scale.

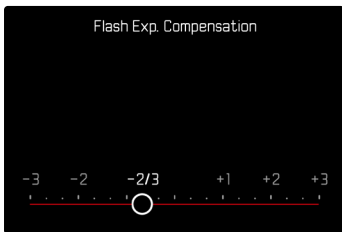

Notes

- The following applies for set compensation values, no matter how they were initially set: They remain effective until they are manually reset to **0**, even if the camera is switched off and on again in the meantime.
- The menu item **Flash Exp. Compensation** can only be used in conjunction with flash units on which the compensation value cannot be set manually (e.g. Leica SF 26).
- **Flash Exp. Compensation** is unavailable, if flash units with an own compensation function are used (e.g. Leica SF 58 or Leica SF 60). A compensation value set on the camera would in that case have no effect.
- A brighter flash illumination with Plus compensation will require a greater flash intensity. Flash exposure compensation will therefore impact on the flash range: A Plus correction will decrease it, a Minus correction will increase it.
- An exposure compensation set on the camera will only affect the measurement of ambient light. If a simultaneous TTL flash exposure metering compensation is desired in flash mode, then it must be additionally set on the flash unit.

FLASH PHOTOGRAPHY

- Switch on the flash unit
- Set the desired guide number control mode (e.g. TTL or GNC = Guide Number Control) on the flash unit
- Switch the camera on
- Select the desired exposure mode, shutter speed and/or aperture setting
 - It is imperative to take note of the shortest flash sync speed, as it determines whether a “normal” flash or an HSS flash is fired.
- Tap the shutter button before each flash exposure to activate exposure metering
 - The flash unit may not fire if this step is missed by pressing the shutter button down completely and skipping these settings.

Note

- We recommend not using **Spot** as your exposure metering method for flash photography.

REVIEW MODE

There are two completely independent review functions available:

- short-term rendering directly after shooting (**Auto Review**)
- normal review mode, in which the stored images can be viewed and managed for any length of time

The switchover between shooting and review mode, as well as most other actions can be completed using gesture or key control. Please see p. 59 for more information about the available gestures.

Notes

- Recorded images are not automatically rotated in review mode to utilize the full screen area.
- It may not be possible to render files with this camera that were not recorded with this device.
- In some cases, the screen image may not have the expected quality, or the LCD panel will remain blank and only display the file name.
- You can toggle back from review mode to shooting mode at any time by tapping the shutter button.
- The histogram and clipping displays are available only when viewing the full size picture, but not during zooming or in the overview.

CONTROL ELEMENTS IN REVIEW MODE

CONTROL ELEMENTS ON THE CAMERA

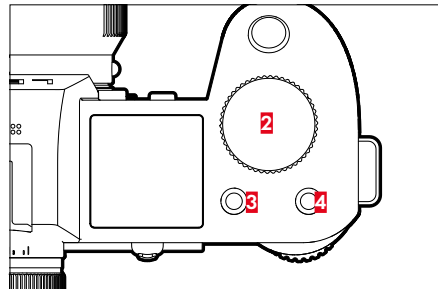
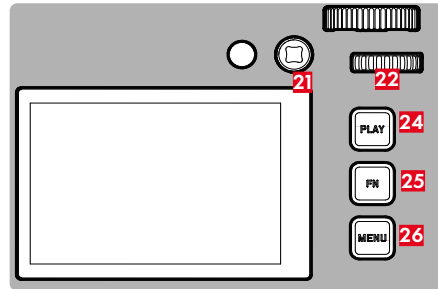

- | | | | |
|-----------|-----------------|-----------|----------------------------|
| 2 | Right dial | 22 | Thumbwheel (turn or press) |
| 3 | Function button | 24 | PLAY button |
| 4 | Function stick | 25 | FN button |
| 21 | Joystick | 26 | MENU button |

DIRECT ACCESS IN REVIEW MODE

The function buttons can have individual assignments in review mode as well.

In factory settings, the function buttons have the following assignments:

| Button | Function |
|---------------------|----------------------------|
| Right dial | Magnification |
| Function button (3) | Delete Single |
| Function button (4) | Mark shots (Rate / Unrate) |
| FN button | Toggle Info Levels |

The descriptions in the next few sections presume factory settings.

Note

- The assigned function is independent of the current display mode; the delete functions overview can therefore be accessed directly in full screen display mode.
- The assigned function is unavailable if the function button addresses an on-screen control element (e.g. in the "Delete" screen).

CONTROL ELEMENTS ON THE LCD PANEL

On-screen control elements generally function by intuitively by touch. Many can also be selected by pressing one of the three buttons to the right of the LCD panel (PLAY button, center button, MENU button). A control element in the header is accompanied by an icon denoting the relevant button. A control element on the edge of the screen will be positioned directly next to the relevant button.

You have e.g. two options to select the Favorites icon ★:

- Tap on the Favorites icon directly
- press the relevant button
(Factory setting: Function button (4))

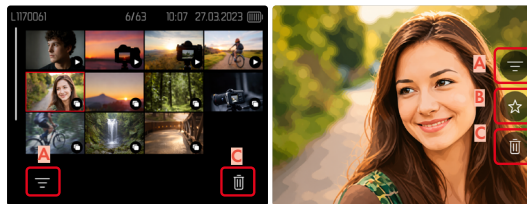

- A** Control element "Filter"
- B** Control element "Favorites"
- C** Control element "Delete"

STARTING/EXITING REVIEW MODE

Using touch control

→ Swipe down

Shooting



Review



Using button control

→ Press the **PLAY** button

- The last captured image appears on the screen.
- The message **No valid picture to play** appears if the inserted memory card does not contain any image data.
- The **PLAY** button function differs, depending on the current camera setting

| Initial situation | After pressing the PLAY button |
|--|---------------------------------------|
| Full screen display of an image | Shooting mode |
| Display of an enlarged cropped section/or several thumbnails | Full screen display of the image |

SELECTING/SCROLLING THROUGH IMAGES

The images are visually arranged in a horizontal reel. The sorting will be strictly chronological. When the end of an image series is reached, the display automatically jumps back to the first image in the series. All images can therefore be reached by scrolling either right or left.

SINGLE

Using touch control

→ Swipe to the left or right



Using button control

→ Press the joystick left/right

or

→ Turn the thumbwheel

CONTINUOUS

- Swipe to the left or right and hold the finger on the edge of the screen
 - The subsequent shots will move past continuously.



STORAGE LOCATIONS

The Leica SL3-P offers two separate internal storage locations plus the option to utilize external storage media via USB-C.

When review mode is accessed, the last captured image will always be displayed first. That also applies on the storage location displayed first.

When scrolling through images and also in the overview, the images saved to the same storage location are available first.

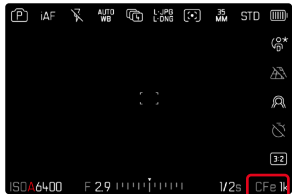

Switching the displayed storage location

- Reduce the view as much as possible (see p. 183)
 - The storage location selection view appears.
 - The currently selected storage location is displayed with a color fill.



- Press the directional pad left/right
 - The newly selected storage location appears with a color frame.
- Press the center button
- Re-enlarge the view

INFO DISPLAYS IN REVIEW MODE

Virtually the same Info Profiles are available in review mode as in shooting mode. The actual info profile currently in use, however, is saved separately. It is therefore possible to use an empty info profile completely without assist function icons in review mode, without having to set them again when switching to shooting mode. See p. 109 for setting options and additional information. The assist functions **Grids**, and **Level Gauge** are not displayed in review mode.



Info Bars



Empty info profile

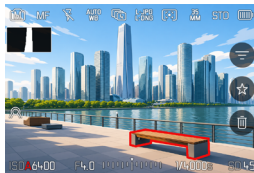

Info Bars, Focus Peaking, Histogram



Info Bars, file information

Switching between info profiles

- Press the **FN** button
 - The info bars appear (header and footer line always appear/disappear together in review mode).
 - The displays for **Histogram** and **Clipping** will appear if these functions are activated.



Full screen

PICTURE SERIES REVIEW

Serial and interval shootings often produce a large number of individual images. It would be very difficult to find other pictures that are not part of a series if every image of all these series was displayed individually. Organizing the images in groups creates more clarity in review mode.

Factory setting: **Off**

→ Select **Group Display Mode** in the main menu

→ Select **On**

All images in all series are displayed individually if **Off** is selected. The images are grouped in series and only one representative image will be displayed if **On** is selected. Only that one representative image will be displayed and all other images in that series are hidden during scrolling.



The representative image is shown with **▶** in the center and **1/8** at the bottom left.

There are two options for viewing the images in a group: manual scrolling or automatic playback. Automatic review is the default setting.

UNINTERRUPTED PLAYBACK OF THE PICTURE SERIES

The images in a group can be played back from start to finish without interruption. This may be very helpful to get a better idea of the processes or conditions rendered than if the images were scrolled manually.

→ Tap **▶**

or

→ Press the joystick/thumbwheel

- Auto Review commences.

PAUSE PLAYBACK

→ Tap anywhere on the LCD panel

or

→ Press the joystick/thumbwheel

- Playback stops, the current picture in the series is displayed.

RESUMING PLAYBACK

While the control elements are visible:

→ Tap anywhere on the LCD panel

or

→ Press the joystick/thumbwheel

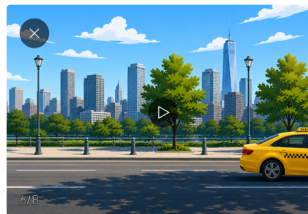

SAVE AS A VIDEO

The frame series can additionally be saved as a video.

- Starting and stopping review
- Press the **MENU** button
- Select **Yes/No**
 - **Yes**: A video is created
 - A progress screen for the video creation is displayed briefly (while the data is being processed). It also offers the option of canceling the process by pressing the center button.
 - Once video creation is complete, the first frame of the new video is displayed.
 - **No**: Revert to the same picture of the (still paused) automatic review

SCROLLING THROUGH THE INDIVIDUAL PICTURES OF A SERIES

The images in a picture series can also be viewed individually. Switch to the manual scrolling function to do so.





- Press the joystick up/down
 - The information displays disappear in full-screen mode.
 - Activated information displays will show information in the image on the left.
 - Press the joystick left/right
- or
- Swipe left

Returning to standard review mode

- Press the joystick up/down

Notes

- The review will be limited to the current picture series while you are scrolling in that series. The same applies for the overview with 9 or 16 thumbnails.
- The images of a series are marked with  in the header line, those of an **Interval Shooting** shoot by a .

CROPPED SECTION ZOOM

You can zoom in to any section of an image for closer inspection. You have a five-step zoom factor available via the thumbwheel, while zooming is stepless if you use touch control.

Using touch control



- Two-finger pinch/spread
 - The image will be zoomed in/zoomed out at the desired point.



- Move the position of an enlarged cropped section by swiping
 - The rectangle within the frame at the top right represents the current magnification, as well as its position in the displayed cropped section.



- Double tap
 - Toggles between the third zoom increment at the tap position and standard full screen view.

Using button control

→ Turn the right dial
(in clockwise direction: increase magnification, anti-clockwise: decrease magnification)

or

- Press the joystick/thumbwheel
- Toggles between the third zoom increment at the tap position and standard full screen view.
- Use the joystick to move the position of the cropped section while the image is magnified
- The rectangle within the frame at the top right represents the current magnification, as well as its position in the displayed cropped section.

You can move directly from one image to the next in magnification mode, which will then also be displayed with the same magnification.

→ Turn the thumbwheel to the left/right

Notes

- It may not be possible to enlarge images taken with other camera types.
- Video recordings cannot be enlarged.

DISPLAYING MULTIPLE IMAGES AT ONCE

The camera offers an overview function in which several thumbnail images can be viewed on one screen, which makes it easier to find a specific image. Choose to display 9 or 16 thumbnails for your overview.

OVERVIEW

Using touch control

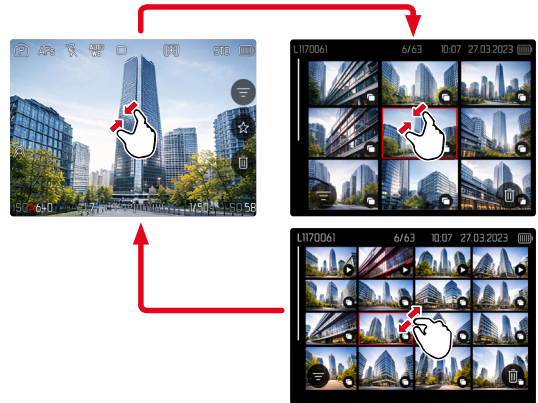

- Two-finger pinch
- The display toggles between 9 or 16 thumbnails.

Viewing other images

→ Swipe up or down

Using button control

- Turn the right dial in anti-clockwise direction
 - An overview with 9 thumbnails is displayed.
Another turn on the dial increases the number of displayed thumbnails to 16.



- A** Currently selected image
- B** Number of the currently selected images
- C** Scrollbar

The currently viewed image is framed in red and can be selected for a closer look.

Navigating between images

- Press the joystick in the relevant direction
or
- Turn the thumbwheel

Displaying the image in full size

Using touch control

- Two-finger spread
or
- Tap the desired image



Using button control

- Turn the right dial in clockwise direction
or
- Press joystick, thumbwheel or **PLAY** button

TAGGING/RATING OF IMAGES

Images can be marked as favorites to find them quicker or to simplify the later deletion of multiple images. Tagging can be done in regular view mode or in the overviews.

Tagging a photos

→ Press the function button **(4)**

or

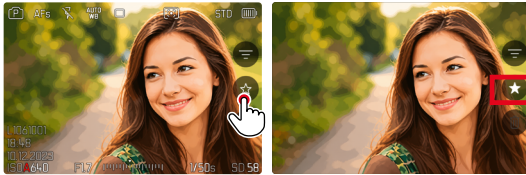

- Tap the ★ icon
- The ★ icon is highlighted.
 - The icon will appear in the header on the far right when viewing images in full size, and in the lower left corner of the thumbnail overview.

Removing a tag

→ Press the function button **(4)**

or

→ Tap the ★ icon

DELETING IMAGES

There are several methods available to delete images:

- deleting individual images
- deleting multiple images
- deleting all images without a icon/ranking
- deleting all images

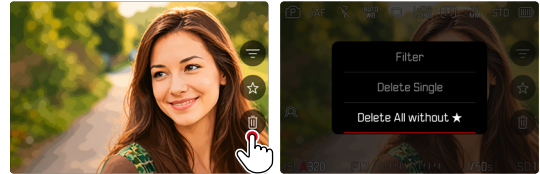

Important

- Once deleted, images are no longer retrievable.

DELETING INDIVIDUAL IMAGES



→ Tap the Delete  icon

- A confirmation prompt appears.
- The LED will flash during the delete process. The process may take a few seconds.
- The next image will be displayed once deletion is complete. The message **No valid picture to play** appears if no other images are saved on the card.

or

→ Press the function button 

- The Delete screen appears.

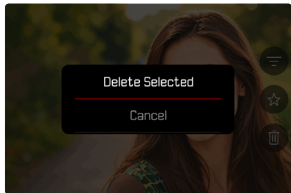

Cancelling a deletion and returning to normal review mode

→ Press the **PLAY** button

Note

- The Delete screen can be called up only by pressing the **MENU** button when in overview mode, because the menu function **Delete** of the “Play menu” is not available in this context.

DELETING MULTIPLE IMAGES

You can highlight multiple images in a Delete overview with twelve thumbnails for simultaneous deletion.

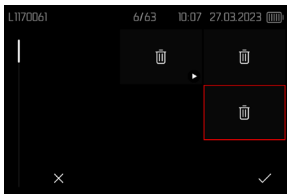

- Turn the right dial to the left
 - The overview screen appears.
- Press the **MENU** button
- Select **Delete Multi**
 - The Delete overview appears.

Any number of images can be selected in this view.

Selecting images for deletion

- Select an image
 - Press the joystick/thumbwheel
- or
- Tap the desired image
 - The images selected for deletion are marked with a red Delete icon .

Deleting the selected images

- Press the **MENU** button

or

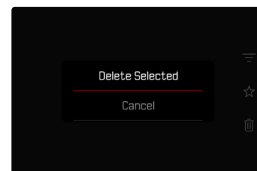
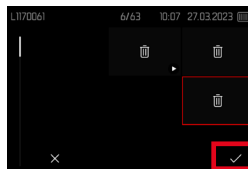

- Tap the “Confirm” icon
- Select **Delete Selected**
 - The images selected for deletion are marked with a red Delete icon .

Cancelling a deletion and returning to normal review mode

- Press the **MENU** button

DELETING ALL UNRATED IMAGES

- Press the **MENU** button
- Select **Delete All without ★**

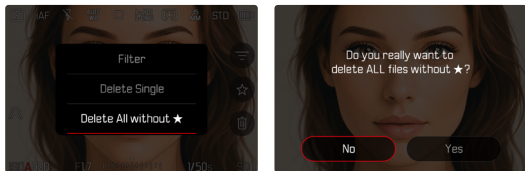

- The confirmation prompt **Do you really want to delete ALL files without ★?** appears.
- Select **Yes**
- The LED will flash during the deletion process. The process may take a few seconds. The next marked image appears once deletion is complete. The message **No valid picture to play** appears if no other images are saved on the card.

DELETING PICTURE SERIES

Picture series can be displayed in groups for quick deletion. The pictures will have to be displayed in groups.

- Select **Play Mode Setup** in the main menu
- Select **Group Display Mode**
- Select **On**

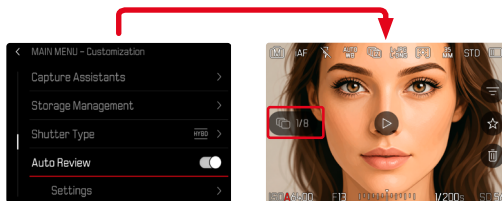

- Select the representative image



- Delete
 - All pictures in the picture series will be deleted.

PREVIEW OF LATEST IMAGE

Photos can be displayed automatically directly after they are taken to e.g. check the success of the shots quickly and easily. A duration for the automatic display can be configured.

- Select **Auto Review** in the main menu
- Select **Setting**
- Select the desired function or duration in the submenu (**1 s**, **3 s**, **5 s**, **Permanent**, **Shutter Button Pressed**)
- **Permanent**: The most recent frame is displayed until automatic review is ended by pressing the **PLAY** button or by tapping the shutter button.
- **Shutter Button Pressed**: The most recent frame is displayed for as long as the shutter button is pressed down.

Notes

- Various control elements change back to regular review mode to execute their normal functions while automatic review is selected. The camera will remain in review mode until it is exited.
- Marking and deleting can only be done in regular review mode and not during automatic review.
- When shooting with the Continuous Shooting or Interval Shooting functions, then the last image in the series will be displayed or – if the save process is still incomplete – the last image in the series saved to the memory card.
- Where display times were configured (**1 s**, **3 s**, **5 s**) automatic review can be ended immediately by pressing the **PLAY** button or tapping the shutter button.

VIDEO SETTINGS

VIDEO PROFILES

The available video formats are defined in 4 preset video profiles, plus one additional profile that can be user-customized. However, due to the large number of possible combinations of resolution, frame rate, codec, and additional parameters, the selection process can quickly become difficult to navigate. To simplify configuration, a guided filter view is available. It walks the user through each setting step by step. With each selection, only video formats that are compatible with the parameters chosen are shown at the top of the screen. Unsupported combinations are automatically hidden. This allows the desired video profile to be assembled precisely and efficiently – without conflicting settings or lengthy trial and error.

SETTING THE VIDEO FORMAT

Via the Control Center



Via the menu



- Select **Video Profiles** in the main menu
- Select a profile

Profile editing

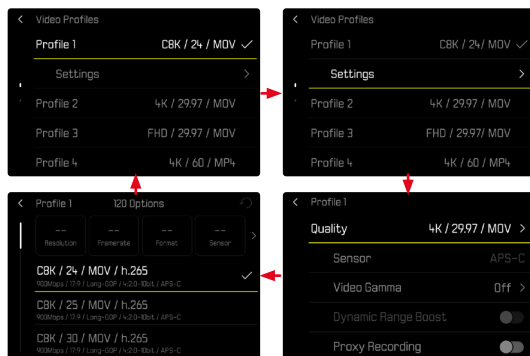

- Select **Video Profiles** in the main menu
- Select a profile
- Choosing the resolution, frame rate, format, and sensor size
 - The filter display at the top of the screen provides information at each step about remaining selectable options.

Note

- Pressing the joystick to the right will switch the display from the list view to the filter selection.

SENSOR FORMAT

The image data of the entire 35 mm sensor can be used or only that of a cropped section, which corresponds to the APS-C format. This can be helpful, e.g. when only limited storage capacity remains or a lens developed specifically for APS-C is used.

- Select **Sensor** in the main menu
- Select the desired setting
(**35 mm**, **APS-C**)

Note

- The setting switches automatically to APS-C when an APS-C-specific lens is mounted.

FILE FORMAT

Video can be recorded in the file formats MOV, MP4 and RAW.

Various combinations of resolution and frame rate can be configured depending on the file format chosen. The settings are done separately. You could therefore select the combination **C4K/29.97 fps** for the MOV format or **FHD/59.94 fps** for MP4. The preset video format settings are then accessed automatically, when one of the two file formats is selected.

VIDEO GAMMA

Video gamma can be set to HLG and L-Log or can be deactivated altogether.

| | |
|-------|---|
| Off | Optimization for playback compatible with all screen/TV devices in compliance with the BT.709 standard. |
| HLG | Optimization for HDR-capable UHD-TV devices. |
| L-Log | Optimization for professional reworking, e.g. color grading. |

Factory setting: Off

- Select **Log Settings** in the main menu
- Select **Video Gamma**
- Select the desired setting
(Off, HLG, L-Log)

Notes

- **Video Gamma** is not available under the following conditions:
 - Recordings in MP4 format
 - Recordings in 8 bit
 - Recordings in slow motion
- The following functions are unavailable when **Video Gamma** is used:
 - **iDR**
 - **Video Style**

DYNAMIC RANGE BOOST

Dynamic Range Boost increases the usable dynamic range of the sensor, and facilitates more detail in bright and in dark image areas (up to 13.5 aperture increments instead of 12.5).

- Select **Video Profiles** in the main menu
- Select a profile
- Select **Dynamic Range Boost**

Note

- When Dynamic Range Boost is enabled, then the frame rate is limited to 30 fps, and the rolling shutter effect may increase.

PROXY RECORDING

Proxy Recording creates a smaller, easier to process video file in addition to the original recording. Recordings can be sorted, transferred, and edited more easily – especially helpful with high resolution material.

- Select **Video Profiles** in the main menu
- Select a profile
- Select **Proxy Recording**

LEICA LOOKS

The image properties of picture and video recordings can be changed easily via various parameters. These are summarized in pre-configured **Leica Looks** profiles. Furthermore, additional Leica Looks can be downloaded and transferred via Leica FOTOS.

Pre-installed are:

- **Standard**
- **Vivid**
- **Natural**
- **Monochrome**
- **Monochrome High Contrast**

- Select **Leica Looks** in the main menu
- Select a profile

Note

- The **Leica Looks** function is unavailable if any other setting but **Off** is selected for **Video Gamma**.

CUSTOMIZING LEICA LOOKS

These parameters can be adjusted for all pre-installed 'Core Looks'.

- Select **Leica Looks** in the main menu
- Select a profile
- Select **Customize**

For **Standard/Monochrome**:

- Select **Contrast/Highlight/Shadow/Sharpness/Saturation**
- Select the desired level
(-2, -1, 0, +1, +2)

For **Vivid/Natural/Monochrome High Contrast**:

- Select **Intensity/Contrast/Highlight/Shadow/Sharpness/Saturation**
- Select the desired intensity or level
(10%-100%/-2, -1, 0, +1, +2)

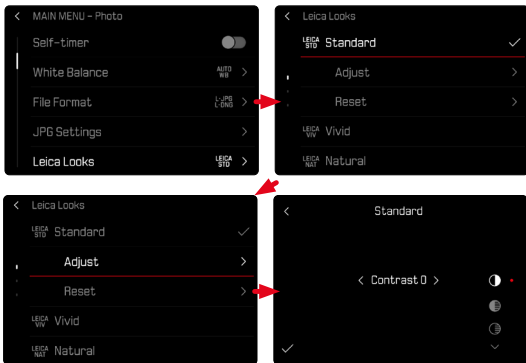

DOWNLOADING LEICA LOOKS

Additional Leica Looks can be downloaded and transferred via Leica FOTOS.

- Select **Leica Looks** in the main menu
- Select **Download Leica Look**

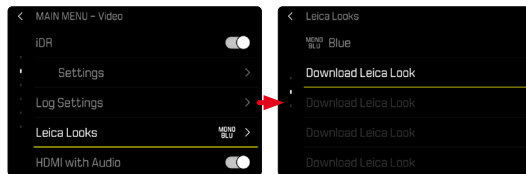

Note

- Only selected customization options are available for Leica Looks that can be additionally installed.

RESETTING LEICA LOOKS

- Select **Leica Looks** in the main menu
- Select **Restore**

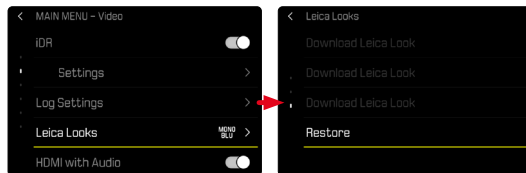

Note

- Only customizable Leica Looks can be reset.

AUDIO SETTINGS

MICROPHONE

The sensitivity of the integrated microphone can be set. Factory setting: **0 dB**

Via the Control Center

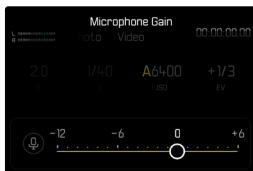
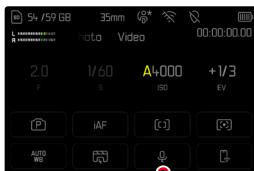

Notes

- The Autofocus function and manual focusing adjustments generate noise that may be picked up in the recording.
- There will be no audio recorded if this setting is **Off**. As notification, the icon for the recording level changes as shown here .

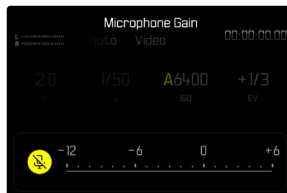

Via the menu

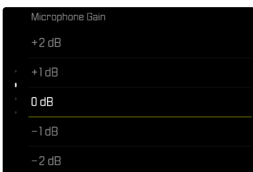
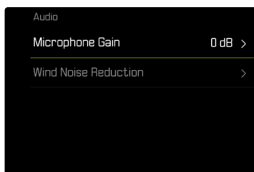

- Select **Audio** in the main menu
- Select **Microphone Gain**
- Select the desired level
(**Off**, **+6 dB**, **+5 dB**, **+4 dB**, **+3 dB**, **+2 dB**, **+1 dB**, **0 dB**, **-1 dB**, **-2 dB**, **-3 dB**, **-4 dB**, **-5 dB**, **-6 dB**, **-7 dB**, **-8 dB**, **-9 dB**, **-10 dB**, **-11 dB**, **-12 dB**)

WIND NOISE REDUCTION

Wind noise reduction can be adjusted individually for the internal and the external microphone.

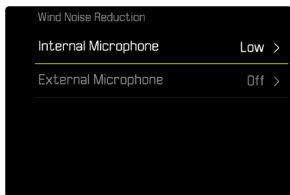

INTERNAL MICROPHONE

Factory setting: **Low**

- Select **Audio** in the main menu
- Select **Wind Noise Reduction**
- Select **Internal Microphone**
- Select the desired setting
(**High**, **Low**, **Off**)

EXTERNAL MICROPHONE

Factory setting: **Off**

- Select **Audio** in the main menu
- Select **Wind Noise Reduction**
- Select **External Microphone**
- Select the desired setting
(**High**, **Low**, **Off**)

TIMECODE

The timecode is a data record that is generated and recorded alongside the image and audio data. It ensures the correct time assignment of frame and audio signals after cutting or after later separate processing. Timecode mode and start time can be selected.

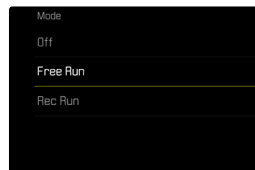
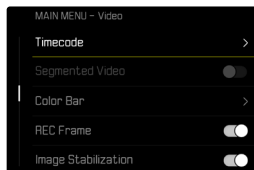

TIMECODE MODE

Time information is written to the recorded video file if the timecode setting is activated.

Factory setting: **Off**

| | |
|-----------------|--|
| Off | Timekeeping begins at 00:00:00.00 for every recording. |
| Free Run | The timer continues running regardless of whether the camera is currently recording video. |
| Rec Run | The timer only runs while a video is being recorded. The timer will stop when recording ends and will continue when the next recording starts. |

- Select **Timecode** in the main menu
- Select **Mode**
- Select the desired setting
(**Off**, **Free Run**, **Rec Run**)

START TIME

The start time can be reset manually or can be set to a specific value if multiple cameras are used for recording. Alternatively, the current time set in the camera can be specified as the timecode.

- Select **Timecode** in the main menu
- Select **Start Time**
- Select the desired setting
(**Reset Timecode**, **Manual**, **Camera Time**)

The desired start time can be set in the format hour:minute:second:frame if **Manual** is selected.

TC SYNCHRONIZATION

There is a choice of two methods for syncing the timecode record: The option **External** applies data from a connected timecode generator. It dictates the timecode signal. The camera applies the data received from the external signal.

The option **Master** forces the camera to apply the timecode signal generated by its internal timecode generator. The externally connected timecode generator applies the signal received from the camera and forwards it to the network.

- Select **Timecode** in the main menu
- Select **TC Synchronization**
- Select the desired setting
(**External**, **Master**)

HLG SETTINGS

Sharpness and saturation can be set. The factory setting is a median value **0** in both cases.

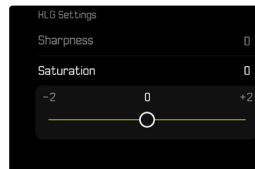
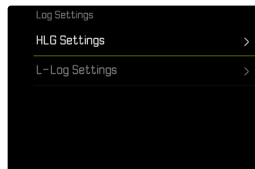

- Select **Log Settings** in the main menu
- Select **HLG Settings**
- Select **Sharpness** or **Saturation**
- Select the desired setting
(**-2**, **-1**, **0**, **+1**, **+2**)

L-LOG SETTINGS

The sharpness for L-Log can be adjusted. Additionally, various LUT profiles can be applied as preview when using L-Log. Saved recordings remain unaffected.

SHARPNESS

Factory setting: **-2**

- Select **Log Settings** in the main menu
- Select **L-Log Settings**
- Select **Sharpness**
- Select the desired setting
(**-2**, **-1**, **0**, **+1**, **+2**)

SETUP/MANAGEMENT OF LUT PROFILES

You can import custom LUT profiles to the camera to optimally meet your LUT preview expectations.

- Select **Log Settings** in the main menu
- Select **L-Log Settings**
- Select **Custom LUT**
 - A list of six memory slots is displayed. Three are reserved for use with HDMI output, and three for internal camera use (LCD panel/EVF).
 - Filled memory slots will show the name of the saved LUT profile. Free memory slots display the word **Unused**.

EXAMPLE

In the following, the assignment shown below will be used for all subsequent figures. Two profile slots for internal camera display (LCD panel/EVF) are taken, all others are unused.

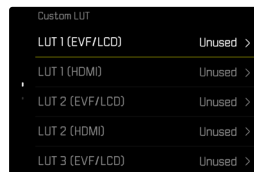
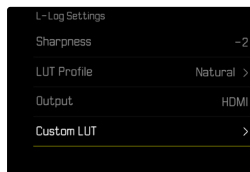

Importing a custom LUT profile

- Download or export an LUT profile as a CUBE file
- Give the file a meaningful name (file name max. 8 characters, file ending “.cube”)
 - This file name (without the ending) will appear as a profile name in the camera after import. A later file name change on the camera will not be possible.
- Save the download to the memory card
 - Store the file in the main directory of the memory card (not in a sub-directory).
- Insert the memory card into the camera
- Select an unused memory slot
 - You will have to delete an existing profile first if there is no unused memory slot available.
 - The “Import” dialog appears. It displays the files found on the memory card.
 - The message **Import Failed** will appear if the camera does not find a compatible file.
- Select the profile to import
- Select **Yes**

Notes

- You can only import LUT profiles with the file ending “.cube”.
- Files with the ending “.cube” will not be recognized. These can, however, simply be renamed before saving them to the SD card.
- File names must be max. 8 characters (incl. spaces) long.
- Incompatible files will not be recognized.
- A maximum of six profiles saved to the memory card will be displayed. The profiles found on the card will be displayed chronologically in ascending order: the most recently saved profile will appear at the top.
- In rare cases, a particular combination of memory card and computer may result in a search returning only three profile files.
- Where two memory cards are in use, and both contain compatible files, only the files on SD1 will be considered.

Freeing a memory slot

- Select a profile
 - The “Delete” dialog appears.
- Select **Yes**

Notes

- The pre-configured profiles **Natural** and **Classic** cannot be deleted.
- A profile that is currently in use cannot be deleted.

USING LUT PROFILES

CHANGING THE OUTPUT CHANNEL

The user can choose to apply the LUT profile for output via HDMI or in the camera (LCD panel/EVF).

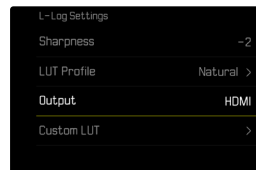
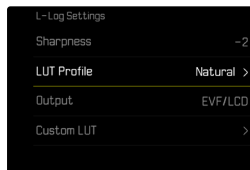

- Select **Log Settings** in the main menu
- Select **L-Log Settings**
- Select **Output**
- Select the desired setting (**EVF/LCD**, **HDMI**)

Note

- The menu item **Output** is unavailable if the setting **Off** is selected for **LUT Profile**.

When toggling between the two output channels, the setting for the selected memory slot will remain unchanged. Since it is possible that different profiles are saved on the same slot depending on the output channel, it is possible that a different profile or an unused memory slot is selected. The name of the active profile will change accordingly next to the menu item **LUT Profile**. This does not apply for the pre-configured profiles, which exist on the same memory slot for both output channels.

SELECTING THE LUT PROFILE

In addition to the two pre-configured LUT profiles, three more memory slots are available for custom LUT profiles.

- Select **Log Settings** in the main menu
- Select **L-Log Settings**
- Select **LUT Profile**
 - The list of profiles available for the active output channel appears.
- Select the desired setting
(**Off**, **Natural**, **Classic**, **LUT 1**, **LUT 2**, **LUT 3**)

Note

- Unused memory slots appear in the list as **LUT 1**, **LUT 2**, and **LUT 3**. A memory slot filled with a custom LUT profile will display its name instead.

The list of selectable LUT profiles depends on the currently selected output channel (camera/HDMI). The channel is displayed next to the menu item **Output**. When the channel is set to **HDMI**, the selection list will display the profiles available for HDMI output. The setting **EVF-LCD** will therefore show the profiles available for camera display.

AUTOMATIC OPTIMIZATION

VIDEO STABILIZATION

With video recording - in addition to optical stabilization by means of appropriately equipped lenses - a independent digital stabilization function is available that can be used with any lens. This function is particularly useful in conjunction with lenses that do not feature an OIS function.

Factory setting: **On**

- Select **Image Stabilization** in the main menu
- Select **On**

DARK AREA OPTIMIZATION (IDR)

DYNAMIC RANGE

The contrast range of an object comprises all levels of brightness from the brightest to the darkest point in the image. All levels of brightness can be captured by the sensor, provided the contrast range of the object is lower than the dynamic range of the camera. In case of significant differences of brightness in the object (e.g. shootings of interior spaces with bright windows in the background, shootings with subject elements in shadow or directly lit by the sun, landscapes with dark areas and a very bright sky), the camera with its limited dynamic range will not be able to map the entire contrast range of the object. Information in 'edge areas' will be lost (under and overexposure).

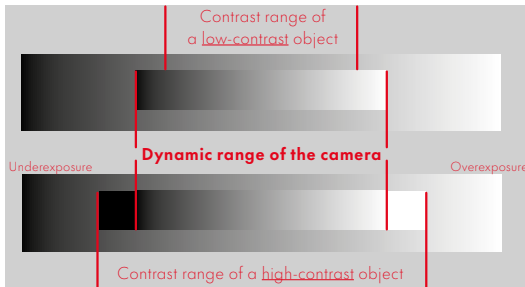

IDR FUNCTION

The **IDR** (Intelligent Dynamic Range) function allows an optimization of the darker areas. Object details become much clearer.



You can specify beforehand if and to what extent you want to optimize darker areas (**High**, **Standard**, **Low**, **Off**). In the **Auto** setting, the camera will automatically select the right setting depending on the contrast range of the object.

In addition to that setting, the effect also depends on the exposure settings. The function will have the strongest effect in combination with low ISO values and fast shutter speeds. The effect is less pronounced with higher ISO values and/or slower shutter speeds.

Factory setting: **Auto**

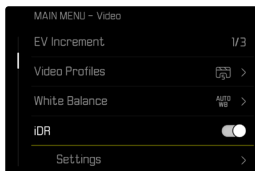

- Select **iDR** in the main menu
- Activate the function
- Select **Settings**
- Select the desired setting
(**Auto**, **High**, **Standard**, **Low**)

Note

- The optimization of darker areas will slightly reduce differentiation in very bright areas.

DATA MANAGEMENT

SEGMENTED RECORDING

Videos recorded in MOV format can be automatically segmented into individual one-minute files and saved. This method protects recordings against technical errors during the write process, in case the recording is interrupted. All previously saved one-minute segments will remain intact.

Factory setting: **Off**

- Select **Segmented Video** in the main menu
- Select **On**

Notes

- This function is not available for the **MP4** video format setting.
- The individual recordings will not be played back automatically in sequence.
- Essential for segmentation is the playback time of the finished recording. Slow motion recordings will be segmented in a way that the finished recordings will have a playback time of about one minute.

FORMATTING A MEMORY CARD

Memory cards that have already been in use with this camera will usually not require formatting. An unformatted memory card that is inserted into the camera for the first time must be formatted. We recommend formatting memory cards from time to time, because residual data traces (data pertaining to individual shots) may reduce the card's memory capacity.

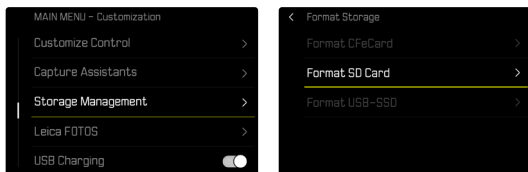

- Select **Storage Management** in the main menu
- Select **Format Storage**
- Select **Format CFe Card/Format SD Card**
- Confirm the selection
 - The status LED will flash during the process.

Notes

- Never switch off the camera while data transfer is in progress.
- All data stored on the memory card will be lost during formatting. Formatting will not be prevented by a deletion protection set for individual shots.
- All images should therefore be regularly transferred to a safe mass storage medium, e.g. the hard disk of a computer.
- A simple formatting process will initially not irretrievably destroy existing data on the card. Only the directory will be deleted, which means the data will no longer be directly accessible. Data access can be restored with appropriate software. Only data that is overwritten when new data is saved will actually be irretrievable.
- A memory card should be formatted again in the camera if it was formatted in another device, e.g. a computer.
- Contact your retailer or Leica Customer Care for assistance if the memory card cannot be formatted/overwritten (see p. 332).
- Depending on the size of the data medium, formatting may take several seconds to complete.

EXTERNAL DATA MEDIUM

The use of an external SSD data medium may be a good solution for storing large data volumes. Photos and videos can then be recorded directly onto a suitable SSD drive via USB-C. The device offers a formatting feature for SSD data media connected via USB-C.

- Select **USB Settings** in the main menu
- **USB SSD** activation

Notes

- A simultaneous recording via USB-C to an SSD data medium and CFe/SD card is not possible.
- SSD data media with a capacity up to 2TB are supported.
- When using the device battery (BP-SCL4), the reduced power availability will prevent the use of external USB-C data media.
- Some functional limitations (8K, 4K, slow motion video recordings, continuous shooting, and the Wi-Fi connection) may occur, once the rechargeable battery has reached a specific discharge threshold.
- USB hubs and USB card readers are not supported.
- The system will need approx. 8 seconds to check the connected external drive and to change mode, once an external USB-C data medium is connected.

DATA STRUCTURE

FOLDER STRUCTURE

The files (= shots) on the memory cards are saved in automatically generated folders. The first three characters signify the folder number (numerals), the last five the folder name (letters). The first folder is assigned the name "100LEICA", the second "101LEICA". A folder will always be created with the next available number; you can have max. 999 folders.

FILE STRUCTURE

The file names in these folders consist of eleven characters. In the factory settings, the first file is named "L1000001.XXX", the second "L1000002.XXX", etc. The first letter can be selected, the "L" from the factory settings denotes the camera brand. The first three characters signify the folder number (numerals). The next four digits denote the sequential file number. Once file number 9999 is reached, then a new folder will be automatically created, in which the file numbering begins at 0001 again. The last three places after the dot denote the file format (DNG or JPG).

Notes

- When using memory cards that were not formatted with this camera, the file numbering will begin with 0001 again. Should the memory card already contain a file with a higher number, then numbering will be continued from that number.
- A relevant message will be displayed on the LCD panel once folder number 999 and file number 9999 are reached, and all numbering must be reset.
- Format the memory card and reset the frame number right after to reset the folder number to 100.

EDIT FILE NAMES

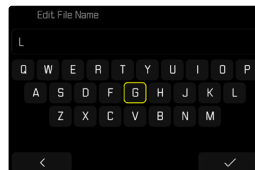
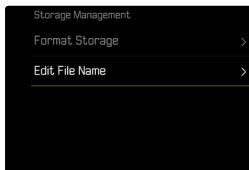

- Select **Storage Management** in the main menu
- Select **Edit File Name**
 - A keyboard submenu is displayed.
 - The input line contains the factory setting "L" as the first letter of the file name. Only this letter can be changed.
- Enter a letter of your choice (see p. 69)
- Confirm

Notes

- The change to a file name applies to all subsequent shots or until a new change is made. The sequential number will not be affected; but it will be reset when a new folder is created.
- During a reset to factory settings, the first letter will always be reset to "L".
- Lower case letters are unavailable.

CREATING A NEW FOLDER

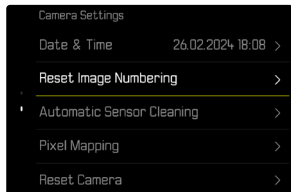

- Select **Camera Settings** in the main menu
- Select **Reset Image Numbering**
 - A relevant prompt is displayed.
- Confirm the creation of a new folder (**Yes**) or cancel the new folder (**No**)

Note

- The name part (first letter) of a new folder created this way remains unchanged. The file numbers in that folder will start again at 0001.

LOGGING THE SHOOTING LOCATION (ONLY IN CONNECTION WITH THE LEICA FOTOS APP)

Location information can be sourced from a mobile device in connection with the Leica FOTOS app. Current location information will then be written to the Exif data of the images (geotagging).



- Activating GPS functions on a mobile device
- Activate Leica FOTOS and connect to the camera (see chapter “Leica FOTOS”)
- Activate geotagging for this camera in Leica FOTOS

Notes

- The use of GPS and associated technologies may be restricted in some countries or regions. Violations will be prosecuted by local authorities. You should therefore contact your travel agent or the embassy of your destination country for relevant information beforehand.
- It will take a few seconds for the Bluetooth connection to establish. The configured shutdown time should be considered when choosing a delay time if shutdown is enabled in the camera.

GEOTAGGING STATUS

The status of the current location information is displayed in the Control Center.

| | |
|--|---|
|  | The location information is current (most recent geolocation max. 15 mins prior). |
|  | The location information is not necessarily current anymore (most recent geolocation max. 12 h prior). |
|  | The available location information is outdated (most recent geolocation more than 12 h in the past). No location data will be written to Exif data. |
| No icon | Geotagging is deactivated. |

Location information will be continuously updated as long as the camera is connected to Leica FOTOS. The Bluetooth function of the camera and the mobile device must therefore remain enabled to ensure latest information. It is, however, not necessary for the app to be running in the foreground.

DATA TRANSFER

Data can be conveniently transferred to mobile devices via Leica FOTOS. Alternatively, a card reader or USB cable can be used for the transfer.

VIA LEICA FOTOS APP

→ See chapter “Leica FOTOS” (p. 292)

VIA USB CABLE OR “LEICA FOTOS CABLE”

The camera supports multiple data transfer options. A transfer mode can be permanently selected or chosen every time a connection is established.

Factory setting: **Select on Connection**

- Select **USB Mode** in the main menu
- Select the desired setting
(**Mass Storage**, **PTP**, **Apple MFi**, **Select on Connection**)
- **Apple MFi** is used for the communication with iOS devices (iPhone and iPad)
- **PTP** allows a data transfer to computers using Mac OS or Windows with PTP-capable programs, as well as tethering to Capture One Pro and Lightroom Classic
- Die setting **Select on Connection** will automatically propose a connection method depending on the type of cable connection.

Notes

- We recommend using a card reader for the transfer of large files.
- The USB connection must not be interrupted while data is being transferred, as the computer or the camera could otherwise “crash” and irreparable damage could occur on the memory card.
- The camera must not be turned off or automatically shut itself down due to a lack of battery power while data is being transferred, as this can cause the computer to crash. For the same reason, the battery must never be removed from the camera while the connection is active.

PRACTICAL DEFAULT SETTINGS

TOUCH AF

Touch AF allows a direct placement of the AF frame.

Factory setting: **Touch AF**

→ Select **Focusing** in the main menu

→ Select **Touch AF**

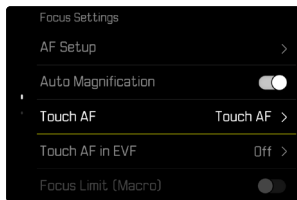

→ Select **Touch AF**

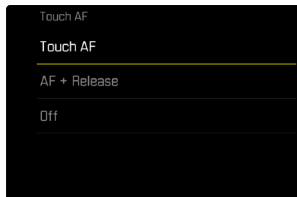

Positioning the AF frame

→ Tap the LCD panel in the desired position

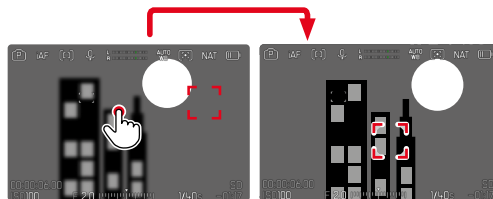

Moving the focus frame back to the center of the screen

→ Double-tap the LCD panel

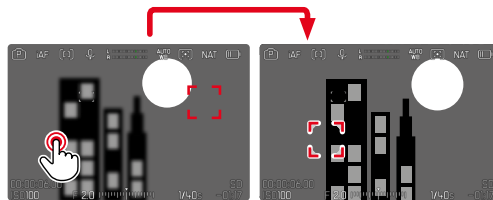

Notes

- This function is available with all AF metering methods except **Multi-Field**.
- The behavior of **Touch AF** depends on the selected combination of **AF Mode** and **AF Detection**. Depending on the setting, the camera will either focus on the selected object (when detection is active) or on the area that was tapped.
- If the metering method **Tracking** is selected, the focus frame will remain at the selected position and auto-focus commences when the shutter button is tapped. For all other AF metering methods, focusing occurs automatically.
- The position of the AF frame can only be reset with a double-tap, even if the setting is **Off**.

TOUCH AF + SHUTTER BUTTON

The combination **Touch AF + Release** allows a direct placement of the AF frame for immediate recording.

- Select **Focusing** in the main menu
- Select **Touch AF**
- Select **Touch AF + Release**
- Tap the LCD panel in the desired position

Note

- The AF frame cannot be reset as usual via a double tap if **Touch AF + Release** is activated.

TOUCH AF IN EVF MODE

Touch AF is deactivated by default when EVF is in use to prevent any inadvertent altering of the AF frame. AF Quick Setting (see p. 243) continues to be accessible. This function can also be disabled if that is not wanted (e.g. when focusing with the left eye).

Factory setting: **Off**

- Select **Focusing** in the main menu
- Select **Touch AF in EVF**
- Select the desired setting
(**On**, **AF Quick Setting only**, **Off**)
- **AF Quick Setting only**
 - Accessing the AF Quick Setting (tap and hold)
- **On**
 - Positioning the AF frame (tap)
 - Accessing the AF Quick Setting (tap and hold)
- **Off**

PERSONALIZED LENS SETTINGS

The total angle of rotation of the lens used for focusing can be individually adjusted. The setting selected indicates the angle of rotation required to change the focus setting from infinity to the nearest possible distance.

Example: for a setting to **90°**, the entire focus range will be run through when the focus ring is turned by one quarter. A full turn of the focus ring will be needed for a setting to **360°**. Smaller values facilitate a faster, larger values a more precise adjustment. A setting to **Maximum** offers the highest precision.

Unlike the permanent settings, a setting to **Standard MF** will result in a non-linear dependency of rotation angle and focus setting. The extent of the change depends dynamically on the speed of rotation. With slow rotation, the same angle of rotation (e.g. 45°) causes a smaller change than with fast rotation.

Factory setting: **Standard MF**

- Select **Focus Settings** in the main menu
- Select **Manual Focus Throw**
- Select the desired setting
(**Standard MF**, **90°**, **120°**, **150°**, **180°**, **210°**, **240°**, **270°**, **300°**, **330°**, **360°**, **Maximum**)

Note

- The settings **Standard MF** and **Maximum** are highly lens-dependent. **Maximum** may, for example, mean a rotation angle of 360° or 720°.

EV INCREMENT

You can choose between 1/2 EV or 1/3 EV graduations. This will allow you to choose between stronger or more subtle effects for your relevant settings.

This setting doesn't just apply for exposure compensation settings. It also specifies the sensitivity of the dials in standard shooting mode, i.e. the increment width with which the shutter speeds and the aperture will be set. A setting to **1/2** will change the shutter speeds and aperture values that much faster each time the dial is moved one click further and the correct setting is achieved quicker. A setting to **1/3** facilitates a more precise setting.

Factory setting: **1/3**

- Select **EV Increment** in the main menu
- Select the desired setting
(**1/2**, **1/3**)

AUDIO OUTPUT

SETTING THE OUTPUT LEVEL

The volume level can be set for connected headphones.

→ Press the function button 

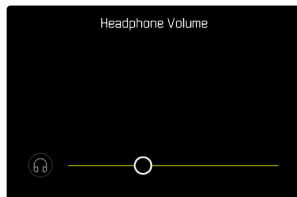

→ Select the desired setting

HDMI OUTPUT WITH/WITHOUT SOUND

HDMI output is available with or without audio.

Factory setting: On

→ Select **HDMI with Audio** in the main menu

→ Select the desired setting

Note

- An output with audio may result in some negligible delays. We recommend the setting Off to avoid this effect (if, for example HDMI Live View is required for a recording with an external recorder).

AUXILIARY DISPLAYS

The Leica SL3-P has 4 independent info profiles, which contain differing combinations of the available auxiliary displays. The following functions are available:

- Info Bars
- Grid lines (shooting mode only)
- Zebra
- Focus peaking
- Level Gauge (shooting mode only)
- Histogram (luminance or Waveform Monitor)
- Framelines

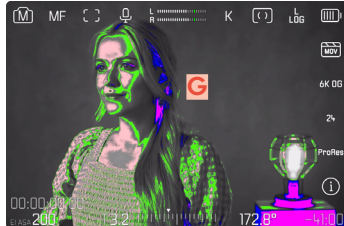
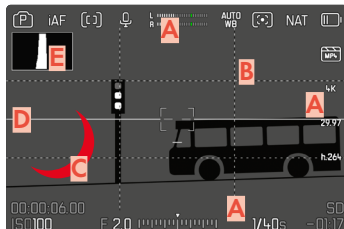

- A** Info bars (= header, footer, bar on the right)
- B** Grid lines
- C** Focus peaking
- D** Zebra
- E** Level gauge
- F** Histogram (depicted here: luminance histogram)
- G** False Color

INFO PROFILES

Up to 4 independent profiles can be used for video mode, plus an additional full-screen mode. The desired function can be selected and adjusted individually for each profile. During operation, the switch between info profiles is done via direct access (see p. 74). In factory settings, that will be the **FN** button. It allows quick switches between various views.

The following profiles are predefined in the factory settings:

| Profile | Factory Settings | |
|---------|--|--|
| 1 | Info bars only (Top / Bottom) | |
| 2 | Full screen view (all auxiliary displays Off) | |
| 3 | Info Bars (Top / Bottom + Right), Zebra, Focus Peaking, False Color, Histogram | |
| 4 | Info Bars (Top / Bottom + Right), Grids, Zebra, Level Gauge | |
| 5 | Full-screen image without displays | |

CHANGING THE INFO PROFILES

- Press the function button with the **Toggle Info Levels** assignment
 - In factory settings, that will be the **FN** button.

Note

- The same info profiles are available in playback mode as in shooting mode. The actual info profile currently in use, however, is saved separately.

Briefly showing/hiding information

- Tap and hold the shutter button
 - (Only) the exposure information and currently active auxiliary functions will be visible.

DEACTIVATING INDIVIDUAL INFO PROFILES

You can limit the number of info profiles by activating/deactivating individual profiles. At least one profile must always be active, but that can be an “empty” profile.

- Select **Capture Assistants** in the main menu
- Select a profile
- Select **On**

CUSTOMIZING THE INFO PROFILES

- Select **Capture Assistants** in the main menu
- Select a profile
- Select **Settings**
- Select the desired function
- Select the desired setting

| Function | Available settings |
|---------------|---|
| Info Bars | Top / Bottom (On, Off) Right (On, Off) |
| Grids | 3 x 3, 6 x 4, Off |
| Zebra | Off, Upper Limit (value between 200 and 255) |
| Focus Peaking | On, Off Color (Red, Blue, Green, White) & Sensitivity (Low, Medium, High): Set- tings apply for <u>all</u> info profiles |
| Level Gauge | On, Off |
| Histogram | Luminance, Waveform Monitor, Off |
| Framelines | – 3 aspect ratio profiles (ration freely adjustable) – 2 completely customizable frame- line profiles (Frame Size, Scale, Shading, Color, Frame Stroke, Frame Type) |

Note

- It is advisable to reserve one info profile as “empty”, in which all functions are set to **Off**. It allows you to temporarily hide all displays. In effect, you get an unobstructed view of the full screen image.

SHOW AVAILABLE

INFO BARS

The icons displayed represent currently active settings and exposure values. See chapter “Displays” for a full list of the various displays (see p. 28).



GRID LINES

The grids divide the image frame into multiple fields. They facilitate pictorial composition and an exact camera orientation. The grid line distribution can be adjusted to fit the object.

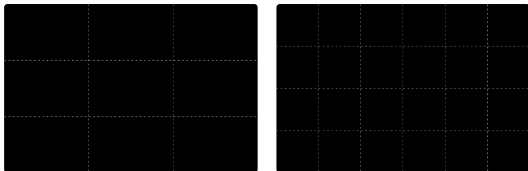

You can choose one of two grid displays. They divide the image field into 3 x 3 or 6 x 4 fields.

- Select **Capture Assistants** in the main menu
- Select a profile
- Select **Setting**
- Select **Grids**
- Select the desired setting
(**3 x 3**, **6 x 4**, **Off**)

ZEBRA

The Zebra display marks very bright image areas. This function is a very easy and exact tool for checking the correct exposure setting. Overexposed areas will appear white with moving black stripes.

SETTING THE LIMIT VALUE

You can set a threshold value for these displays, i.e. define a value at what degree of overexposure they will appear, so that you can adjust these displays to specific conditions or in line with your own composition ideas.

- Select **Capture Assistants** in the main menu
- Select a profile
- Select **Settings**
- Select **Zebra**
- Select **Upper Limit**
- Select the desired value
(**200** to **255**)
- Tap and hold the shutter button
 - The Zebra display appears.

FOCUS PEAKING

This assist function highlights the edges of in focus subject elements in color. The color can be user-specified. The sensitivity can be additionally adjusted.

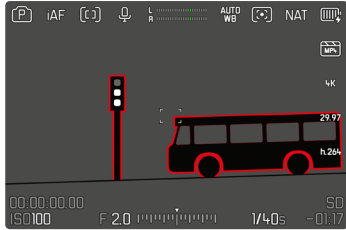

HIGHLIGHT COLOR

The color can be user-specified. This setting will apply for all info profiles.

Factory setting: **Red**

- Select **Capture Assistants** in the main menu
- Select a profile
- Select **Settings**
- Select **Focus Peaking**
- Select **Color**
- Select the desired setting
(**Red**, **Green**, **Blue**, **White**)

SENSITIVITY

Factory setting: **Medium**

- Select **Capture Assistants** in the main menu
- Select a profile
- Select **Settings**
- Select **Focus Peaking**
- Select **Sensitivity**
- Select the desired setting
(**Low**, **Medium**, **High**)

Note

- Focus peaking is based on subject contrast, i.e. differences between light and dark. As a result, high contrast subject elements could be marked, even if they are not completely in focus.

FALSE COLOR

False Color is an exposure tool for video recording. It displays the exposure values of individual pixels as a colored overlay on the screen image, with each color representing a specific brightness range.

This allows exposure to be evaluated with exceptional precision – independent of ambient light or screen settings. False Color is particularly useful for accurately exposing skin tones and helps reliably prevent over- or underexposure.



- Select **Capture Assistants** in the main menu
- Select a profile
- Select **Settings**
- Select **False Color**

HIGHLIGHT COLOR

The color can be user-specified. This setting will apply for all info profiles.

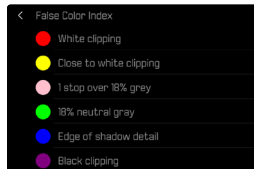
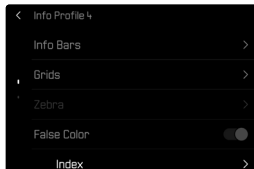

- Select **Capture Assistants** in the main menu
- Select a profile
- Select **Settings**
- Select **False Color**
- Select **Index**
- A color key for the brightness ranges is displayed.

Note

- When False Color is active, other assistants (**Zebra**, **Focus Peaking**, **Level Gauge**, **Histogram**, and **Frame-lines**) are automatically disabled.

LEVEL GAUGE

The integrated sensors of the camera show its orientation. These indicators ensure exact camera orientation along the longitudinal and transverse axes of critical objects, e.g. architecture.

Deviations in relation to the longitudinal axis (i.e. when the camera is tilted up or down in the direction of view) are indicated by a short line in the center of the image

(1). Deviations in relation to the transverse axis (when the camera is tilted to the left or right) are indicated by two long lines to the left and right of the image center (2).



- Select **Capture Assistants** in the main menu
- Select **Level Gauge**
- Select **On**

Note

- The camera will switch the aspect of the level gauge autonomously for shoots in vertical format.

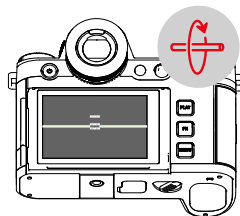
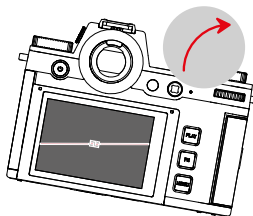
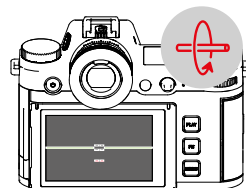
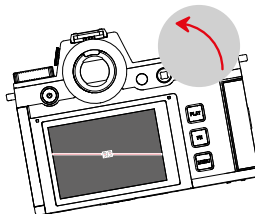
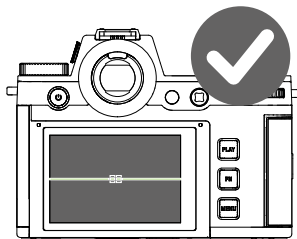

HISTOGRAM

Histogram represents the brightness distribution in the image. The horizontal axis shows the graduated values from black (left) through gray to white (right). The vertical axis corresponds to the number of pixels at each brightness level.

This type of rendering allows an additional quick and easy assessment of the exposure setting.



Factory setting: **Off**

- Select **Capture Assistants** in the main menu
- Select a profile
- Select **Settings**
- Select **Histogram**
- Select **Luminance**

Notes

- The histogram is always based on the brightness displayed; depending on the settings used, it may not represent the final exposure.
- In shooting mode, the histogram should be regarded as a “trend indicator”.
- The histogram during rendering may differ slightly from the one during exposure.
- The Histogram always refers to the currently displayed cropped section of the image.

WAVEFORM MONITOR (WFM)

The Waveform Monitor (WFM) allows a quick and safe assessment of the luminance and color distribution within the current scene. Image faults become more easily apparent, which might otherwise be missed while recording with a smaller screen.

Factory setting: **Off**

- Select **Capture Assistants** in the main menu
- Select a profile
- Select **Settings**
- Select **Histogram**
- Select **Waveform Monitor**



The Waveform Monitor displays the luminance distribution for the entire visible image as a percentage (IRE). A value of 0% corresponds to a luminance value of 16 (in 8-bit encoding), while a value of 100% corresponds to a luminance value of 235 (in 8-bit encoding).

The visualization displays solid lines at 0%, 50%, and 100%. The dotted lines below them represent the values 109% and -4%.



Notes

- Waveform Monitor and Histogram cannot be displayed at the same time.
- The Waveform Monitor will not be displayed on the external device during HDMI output.
- Der Waveform Monitor is available only in shooting mode, not in playback mode.
- The exposure compensation and ISO values (ISO only when accessed directly) can be adjusted using a menu bar. The screen image remains visible and shows the immediate effect of the selected setting. Should the Waveform Monitor be active, then it will remain visible in these cases, and will also display the effects of the latest setting.

ADJUSTING VISUALIZATION

The size and position of the Waveform Monitor can be adjusted to current requirements.

Starting the adjustment

- Touch and hold the LCD panel on the Waveform Monitor
 - White triangles appear at two corners of the Waveform Monitor. All other displays disappear.

Adjusting the size

The size is adjustable in four increments.

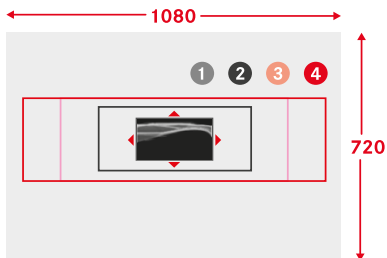

- Turn the thumbwheel
(to the right: larger, to the left: smaller)
- or
- Two-finger pinch/spread

Note

- The Waveform Monitor will appear smaller in the EVF than on the LCD panel.

Adjusting the position

You can choose any position.

- Press the joystick in the relevant direction
- or
- Tap the LCD panel in the desired position

Completing the adjustment

- Press the joystick/thumbwheel
- or
- Tap the shutter button

ASPECT RATIO DISPLAY

The actually recorded aspect ratio depends on the set resolution (see p. 228). It is possible, however, to have colored auxiliary lines displayed to show other aspect ratios (e.g. 4:3). Multiple auxiliary lines can be displayed at the same time. No auxiliary lines are displayed in factory settings.

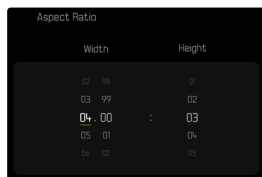

- Select **Capture Assistants** in the main menu
- Select a profile
- Select **Setting**
- Select **Framelines**
- Select the desired setting (4:3, 5:3, 37:20)

Notes

- The format limits of a wider aspect ratio (than that of the recorded video) are indicated by horizontal green lines, those of a narrower one by vertical red lines.
- The auxiliary lines are labeled with the relevant aspect ratio.

FRAMELINE

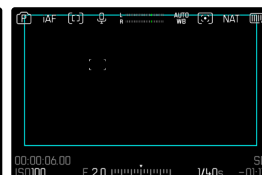
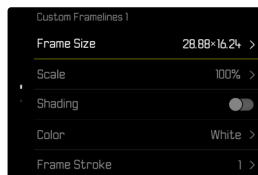

- Select **Capture Assistants** in the main menu
- Select a profile
- Select **Setting**
- Select **Framelines**
- Select a profile (**Custom Framelines 1**, **Custom Framelines 2**)
- Select the desired setting

VIDEO ASSIST FUNCTIONS

REFERENCE VALUES

A color bar can be displayed and also recorded for calibration purposes. A test sound with a frequency of 1 kHz will (optionally, three volume settings) be emitted.

COLOR BAR

A choice of three color bars (SMPTE, EBU, ARIB) is available.

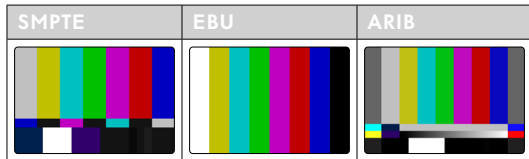

- Select **Color Bar** in the main menu
- Select the desired setting (**Off**, **SMPTE**, **EBU**, **ARIB**)

OPERATING HINT/AUXILIARY DISPLAYS

The test image will always appear regardless of the current Info Profile settings. An operating hint is displayed. The info displays can be accessed at any time.

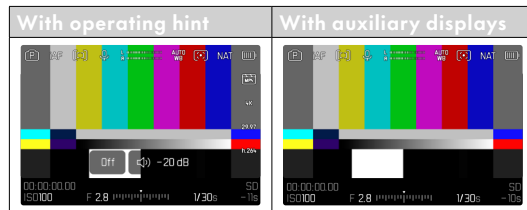

Displaying information and auxiliary displays

- Press the function button with the **Toggle Info Levels** assignment
 - In factory settings, that will be the **FN** button.
 - The operating hint is hidden and the most recently active Info Profile is displayed.
 - The following auxiliary displays will not appear while the color bar is visible: Focus Peaking, Histogram, Level Gauge, Zebra.

Ending the display of the color bar

- Press the joystick/thumbwheel
 - The color bar and test sound end.

TEST SOUND

A test sound with a frequency of 1 kHz will be emitted whenever the color bar is accessed. Der operating hint at the top right of the image shows the current volume. Available setting options: **Off**, **-20 dB**, **-18 dB**, **-12 dB**. The selected setting will remain for all subsequent accesses.

Factory setting: **-18 dB**

Setting the volume

→ Press the joystick left/right

or

→ Turn the thumbwheel to the left/right

Notes

- The operating hint will be hidden after ten seconds have elapsed without any change to the volume setting and will reappear, when the next change is made.
- During HDMI output, the test sound will only be output on the connected device and not on the camera.
- During HDMI output, the test sound will be output on the connected device even if the menu item **HDMI Output** is set to **Without Audio**.
- During HDMI output, the operating hint will only be displayed in Live View mode of the camera, and not on the external device.

USE

For HDMI output, the reference values are used for the configuration of the external device. The reference values can be irrespectively recorded at the start of a video for later use in post-production.

- Select the desired color bar
- Set the volume or mute the test sound
- Display Info Displays as needed
- Press the shutter button
 - Start the recording. The test sound is no longer output via the speakers, but will still be recorded.
- Press the joystick/thumbwheel
 - The color bar and test sound end.
 - Recording continues.

REC FRAME

The timecode counter highlighted in red signifies a running video recording. The option REC Frame offers an even better visualization of the process. With the option set to **On**, the entire screen content will be framed. It will appear in red while the camera is recording video. Factory setting: **On**

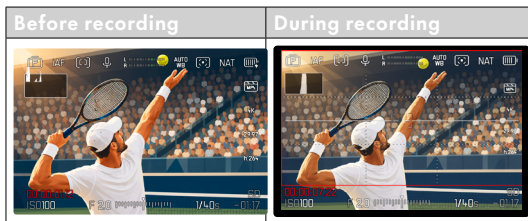

- Select **REC Frame** in the main menu
- Select **On**

Quick option for hiding/displaying the REC Frame

The red dot is part of the info bars and is displayed or hidden alongside them (via the Info profiles). The recording status will still be displayed via the REC frame, without impeding the view of the image content. The REC frame can also be displayed or hidden while recording.

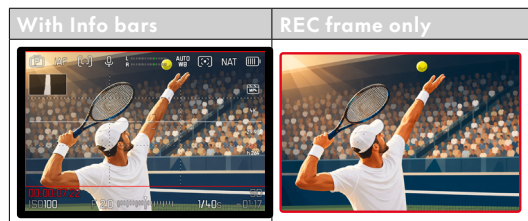

- Assigning the **REC Frame** setting to a function button
- Press the function button
 - Displays/hides the REC Frame.

MF ASSIST FUNCTIONS

AF ASSIST LAMP

The AF assist lamp could be a visible disturbance in video recordings and is therefore always without function in video mode, no matter the setting for **AF Assist Lamp**.

ACOUSTIC AF CONFIRMATION

You can set an acoustic confirmation signal for successful focus metering in AF mode.

- Select **Camera Settings** in the main menu
- Select **Acoustic Signal**
- Select **AF Confirmation**
- Select **On**
- Select **Volume**
- Select **Low/High**

Note

- The signal only appears during the focusing for a recording, not during recording.

RECORDING VIDEO

The settings described in this chapter only apply for video operations. They are therefore part of the video menu and must always be accessed and configured from within video mode (see chapter “Camera operation” in the section “Menu Control”). Any menu items of the same name in the photo menu are not affected.

Notes

- As only part of the sensor area is used in video recordings, the relevantly effective focal length is increased, which slightly reduces the size of the image sections.
- The max. file size for uninterrupted video recording is 192 GB. Once a recording exceeds this file size, the overrun will be automatically stored in a new file.
- Some menu items are unavailable in Video mode. The text in the relevant line is displayed in gray to signify the existence of a submenu.
- Unlike in photo mode, the joystick is used exclusively for focusing (metering and saving) in video mode. A coupling of exposure metering and focusing is not done, no matter which metering method is selected.
- The automatic LCD panel and EVF shutdown will also deactivate the AF system (see p. 87). We therefore recommend the **Off** setting if autofocus is to be used in HDMI recordings.

VIDEO MODE AND CINE MODE

Cine mode is optimized for use by cinematography professionals. The mode is reduced to the most important points and the use of terminology from cinematography ensure a seamless user experience.

(Semi) automatic exposure programs (**P**, **A**, **S**) and the automatic control of light sensitivity (**Auto ISO**, **Float-ing ISO**) remain disabled. Light sensitivity is stated as an **ASA** value.

Unlike other video modes, the shutter speeds are not set as absolutes, but as shutter angles, relative to the selected frame rate.

In conjunction with suitable lenses, the Cine mode allows the Leica SL3-P the use of T-stops to ensure exact same exposure scenarios independent of camera settings.

Factory setting: **Video**

|

Activating Cine Mode

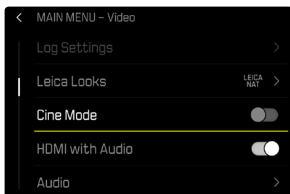

- Select **Cine Mode** in the main menu
- Select **On**

Note

- The settings for light sensitivity (ISO/ASA), aperture and shutter speeds are saved separately for Video and Cine mode.

START/EXIT VIDEO MODE

The camera will always be in Photo mode at initial activation or after a reset to factory settings. There are two methods for toggling between Photo and Video mode:

Using touch control

Variant 1



Variant 2

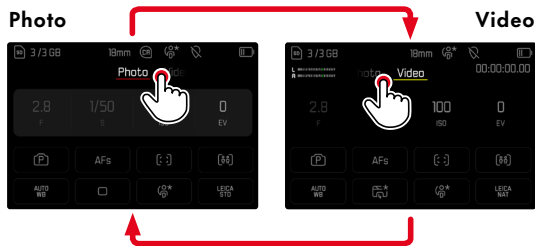

Using button control

- Press the function button with the assignment **Photo <> Video**
 - In factory settings, that will be function button **4** (top left).

Note

- The camera switches to the most recently set photo or video mode.

START/END VIDEO RECORDING

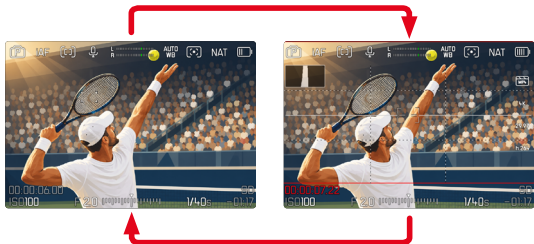

- Press the shutter button
 - Video recording begins.
 - Timecode counter is highlighted in red.
 - Recording time is running.
 - The Status LED flashes.
- Press the shutter button again
 - Video recording ends.
 - Timecode counter is highlighted in gray.

Notes

- The current shooting is shown in the top display with a dot below the mode.
- Basic shooting settings (see p.192) must be configured before shooting.
- No direct access to menu functions is possible during video recording.

DISPLAY AND OPERATION VIA USB-PTP USING EXTERNAL ACCESSORY (LIKE GIMBALS)

Leica SL3-P allows connecting an optional Gimbal like DJI Ronin RS2 via USB-PTP. The Gimbal supports blur-free recordings.

- Select **USB Mode** in the main menu
- Select **PTP** or **Select on Connection**
- Connecting the Gimbal to the camera (see Gimbal operating instructions)

Once the PTP connection is established, the camera can also be triggered via the shutter button on the Gimbal. Many Gimbal models allow controlling the focus function of the camera, provided it is in MF mode.

Note

- The camera screen will switch off for technical reasons if external devices connected to the USB or HDMI output are operated simultaneously.

FOCUSING

Your Leica SL3-P allows automatic as well as manual focusing. There are 3 operating modes and 4 metering methods available for automatic focusing. Only manual setting options are available for MF lenses.

TAKING VIDEOS WITH AF

Focusing is done as needed when **AFs** is in use. The area in the AF metering field will be focused continuously if **AFc** and **Intelligent AF** are in use. Continuous focusing can be suppressed by using a metering memory lock.

TAKING VIDEOS WITH MF

Focusing is done manually via the focus ring. The joystick can be used as needed to do an AF metering (in **AFs** mode).

Note

- Autofocus can be overridden manually at any time by turning the focus ring, while pressing and holding the shutter button at the first pressure point. The set focus will remain unchanged until the shutter button is released.

AUTOFOCUS MODES

The following AF modes are available: **AFs**, **AFc** and **Intelligent AF**. The currently selected AF mode is shown in the header line.

Factory setting: **Intelligent AF**

→ Select **Focus Mode** in the main menu

→ Select the desired setting
(**Intelligent AF**, **AFs**, **AFc**)

INTELLIGENT AF (iAF)

Suitable for all objects. In this mode, the camera will refocus as soon as it registers a color or brightness/contrast change in the entire image section. The focus field depends on the autofocus metering method selected.

AFs (single)

A meaningful option if the focus setting should remain constant for an extended period of time. Allows greater control over focusing and helps to avoid incorrect focusing.

AFc (continuous)

Suitable for objects in motion. Focusing is continuously adjusted to the object in the AF frame.

Facilitates an intuitive focus control, specifically in conjunction with Touch AF.

CONTROLLING THE AUTOFOCUS

TOUCH AF

During video recordings, Touch AF facilitates a more intuitive focus control, even if the main object moves outside the center of the frame.

- Tap the LCD panel in the desired position
 - Focusing is done after the touch.

SUPPRESSING CONTINUOUS FOCUSING

Continuous focus adjustments can be suppressed by initiating a metering memory lock.

Use the following control elements depending on the currently selected mode:

| | |
|----------------|-------------------------------|
| Intelligent AF | Shutter button (tap and hold) |
| | Joystick (press and hold) |
| AFc | Joystick (press and hold) |

The camera stores the focus setting. That makes it easier to change the image section when focusing is fixed. The focus remains constant as long as the control element is held. Automatic focusing will only resume after the control element is released.

AUTOFOCUS METERING METHODS

The AF mode offers various metering methods for focusing. A successful focus setting is identified by a green frame, an unsuccessful one is shown in red.

In the **AF Mode** section, the focusing types **Field / Spot**, **Zone / Multi-Field**, and **Tracking** can be selected. The functions Eye/Face/Body Detection and Animal Detection are available under **AF Detection**. They allow a flexible combination of autofocus behavior and subject recognition.

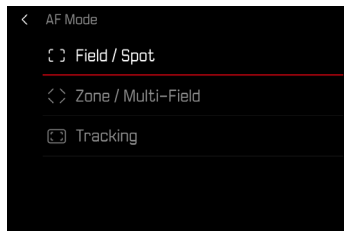

- Select **AF Mode** in the main menu
- Select the desired setting (**Field / Spot**, **Zone / Multi-Field**, **Tracking**)

Notes

- AF focusing can be unsuccessful:
 - if the distance to the subject is too great or too small
 - if the object is not sufficiently illuminated
- Touch AF allows a direct placement of the AF frame.

ZONE/MULTI-FIELD METERING

Multiple focus frames in one area are detected automatically. The size of this area can be changed much like the AF frame (see “Accessing AF quick settings”), and with it the area in which focal points are detected. This feature is particularly useful for snapshots and combines well with Eye/Face/Body Detection.



Zone



Multi-field

FIELD/SPOT METERING

Both methods detect the parts of the subject elements within the relevant AF frames. The metering fields are indicated by a small frame (field metering) or a cross (spot metering). The very small measuring range for spot metering allows focusing on tiny details of the subject. The smallest possible frame setting corresponds to spot metering.

The slightly larger measuring range in field metering is less critical for focusing, but still permits selective metering.

These metering methods can also be used for serial exposures in which the part of the object you want to focus on will always be at the same off-center position in the image. Simply move the AF frame to another position.

TRACKING

This field metering variant helps in the capture of moving objects. The focus on the object in the focus frame is continuously adjusted, once it is detected.

- Aim the focus frame at the desired object (by panning the camera shifting the focus frame)
- Tap and hold the shutter button

or

- Press and hold the joystick
 - The camera focuses on the object.
 - The focus frame “tracks” the saved object and focus is continuously adjusted.

Note

- This metering method focuses continuously, even if the AF mode **AFs** was set.

START POSITION FOR TRACKING

Factory setting: **Center**

You can specify the starting point for tracking.

| | |
|---------------|---|
| Last Position | Ending position of the most recent tracking |
| Recall | Starting position of the most recent tracking |
| Center | Center of the screen |

- Select **Focus Settings** in the main menu
- Select **AF Setup**
- Select **AF Tracking Start Position**
- Select the desired setting
(**Last Position**, **Recall**, **Center**)

AF DETECTION AUTOMATIC SUBJECT RECOGNITION

The camera automatically detects various objects – including people, animals, and vehicles – and focuses specifically on eyes, faces, bodies, or vehicle parts. The main subject remains reliably in focus, even if there is movement or a brief obstruction. Automatic subject recognition provides precise and continuous focus tracking in every shooting situation.

- Select **AF Detection** in the main menu
- Select the desired setting
(**Off**, **Human (Eye/Face/Body)**, **Human (Eye/Face)**,
Animal (Body), **Animal (Eye/Body)**, **Car**, **Car (Parts)**)



When face detection detects an eye, the focus will be on that eye. Should more than one eye be detected, then the user can choose the eye to focus on. The currently selected eye will be highlighted.

- Press the joystick in the desired direction

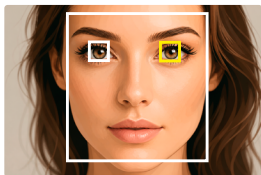

In **Car** detection mode, objects that are further away or moving quickly are prioritized.

- Select **AF Detection** in the main menu
- Select **Car**



Car (Parts) detection is suitable for closer details of the vehicle or driver (bodywork components, helmet etc.).

- Select **AF Detection** in the main menu
- Select **Car (Parts)**



Note

- The subject detection mode **Car** is optimized for race cars; low-contrast road vehicles (e.g. white or gray) may be detected less reliably.

AF MODE / AF DETECTION COMBINATION

With Zone / Multi-Field metering, the desired focus point can be selected from all subjects detected within the measurement area.

- Press the joystick in the desired direction
 - A white outline indicates recognized objects, while a yellow outline highlights the selected object.



AF SETTINGS

SENSITIVITY

Specifies the sensitivity of contrast metering.

Factory setting: **0**

- Select **Focus Settings** in the main menu
- Select **AF Setup**
- Select **AF Sensitivity**
- Select the desired setting
(**-3**, **-2**, **-1**, **0**, **+1**, **+2**, **+3**)

SPEED

Where objects are not as fast-moving, it is advisable to set AF Speed to a slightly lower value. This will prevent overly abrupt focus changes. For very fast-moving objects, a high setting will guarantee a correct focus.

Factory setting: **0**

- Select **Focus Settings** in the main menu
- Select **AF Setup**
- Select **AF Speed**
- Select the desired setting
(**-5**, **-4**, **-3**, **-2**, **-1**, **0**, **+1**, **+2**, **+3**, **+4**, **+5**)

FOCUS LIMIT

The focus area can be limited to the macro range. This will speed up automatic focusing considerably.

Factory setting: **Off**

→ Select **Focus Settings** in the main menu

→ Select **Focus Limit (Macro)**

→ Select **On**

Notes

- The focusing range differs depending on the lens used (see relevant instructions).
- This function is not available for specific lenses:
 - lenses mounted via an adapter (e.g. Leica M lenses with L adapter M)
 - specific Leica SL lenses

AF QUICK SETTING

The AF Quick Setting allows quick changes to the focus frame size in some AF metering methods.

The screen image will remain visible continuously while settings are being adjusted.

ACCESSING AF QUICK SETTING

→ Tap and hold the LCD panel

- All auxiliary displays are hidden.
- Markers appear at two corners of the focus frame when the metering method **Field / Spot**, **Zone / Multi-Field** is set.

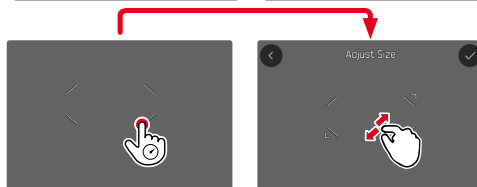
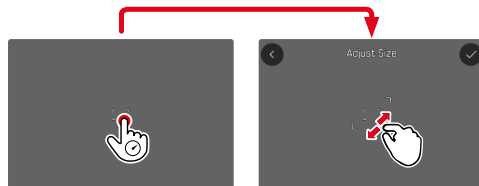

- In all other AF modes, the **AF Mode** menu bar will be displayed directly.

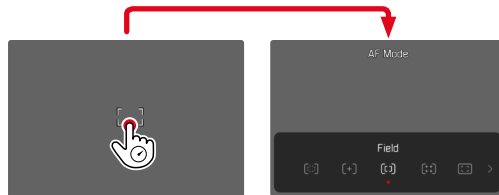

ADJUSTING THE AF FRAME SIZE

(only **Field / Spot**, **Zone / Multi-Field**)

→ Turn the thumbwheel

or

→ Two-finger pinch/spread

- The size of the AF frame is adjustable in 4 increments.

CHANGING THE AF METERING METHOD

Should the active AF mode be **Field** or **Eye/Face/Body Detection**, then the user will have to access the **AF Mode** menu bar first:

→ Press the function button at the front (bottom)

- The **AF Mode** menu bar appears.

→ Use the thumbwheel to select the desired metering method

- Alternatively, you can use the right dial for the setting.
- The setting is applied automatically after 3 seconds, the menu bar disappears.

Note

- AF Quick Setting can only be accessed via the right dial if the function **Touch AF** is active (see p. 75).

MF ASSIST FUNCTIONS

ENLARGEMENT IN AF MODE

You can access the enlargement function independent of focusing for a better assessment of the settings.

The function **Magnification** must be assigned to one of the function buttons to use this feature (see p. 74).

Factory setting: Function button at the front (top)

Assigning a function to a specific function button

→ See p. 74

Accessing the enlargement function

→ Press the function button

- An enlarged image section appears. The position of the enlargement depends on the position of the AF frame.
- The rectangle within the frame at the top right represents the current magnification, as well as its position in the displayed cropped section.



Adjusting the enlargement function

- Turn the thumbwheel
 - The image section toggles between magnification factors.

Changing the position of the enlarged section

- Press the joystick in the relevant direction

Exiting the enlargement function

- Tap the shutter button

or

- Press the function button again

Notes

- The enlargement function remains active until it is exited.
- The most recently magnification function will still be active the next time the feature is accessed.

AF ASSIST LAMP

The AF assist lamp is not active in video mode.

ACOUSTIC AF CONFIRMATION

You can set an acoustic confirmation signal for successful focus metering in AF mode (see p. 88).

Note

- This function is unavailable while recording.

SHIFTING THE AF FRAME

All AF metering methods permit shifting the AF frame before focusing.

→ Press the joystick in the relevant direction

or

→ Tap the LCD panel in the desired position
(While Touch AF is activated)

Notes

- The focus frame will remain at the most recently used position for this AF metering method even if the user changes the AF metering method or the camera is switched off.
- The metering fields are joined together when the exposure metering method **Spot** is combined with the AF metering methods **Spot**, **Field** and **Zone**. Exposure metering will then occur at the point specified by the AF frame, even if it is moved.

MANUAL FOCUSING (MF)

Manual focusing offers more control and is less prone to incorrect settings than the AF modes.

→ Select **Focus Mode** in the main menu

→ Select **MF**

→ Start video recording

→ Turn the focus ring to select the desired focusing

MF ASSIST FUNCTIONS

The following assist functions are available in MF mode.

FOCUS PEAKING

This assist function highlights the edges of in focus subject elements in color.

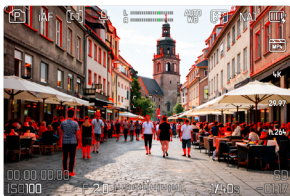

When Focus Peaking is activated,  will appear to the right of the frame with a display of the color used. The color can be user-specified. The sensitivity can be additionally adjusted. The activation of this function is controlled via the info profiles (see p. 220).

- Activate the function
- Turn the focus ring to mark the desired subject elements

Note

- Focus peaking is based on subject contrast, i.e. differences between light and dark. As a result, high contrast subject elements could be marked, even if they are not completely in focus.

ENLARGEMENT IN MF MODE

The larger the details of the object are shown, the better you can assess their sharpness and the more accurately you can focus.

This function can be automatically activated during manual focusing or can be accessed independently.

ACCESS VIA THE FOCUS RING

Turning the focus ring will automatically enlarge a image section.

- Select **Focus Settings** in the main menu
- Select **Auto Magnification**
- Select **On**
- Turn the focus ring
 - An enlarged image section appears. The position of the enlargement depends on the position of the AF frame.
 - The rectangle within the frame at the top right represents the current magnification, as well as its position in the displayed cropped section.
 - The enlargement starts at the 1st of 3 enlargement increments.

Adjusting the enlargement function

- Turn the thumbwheel/right dial

Changing the position of the enlarged section

- Move the position of an enlarged cropped section by swiping

or

- Press the joystick in the relevant direction

Exiting the enlargement function

→ Tap the shutter button

or

→ Decrease the enlargement, until the full image is visible again

Notes

- The magnification will automatically return to normal viewing size about 5 s after the last movement of the focus ring.
- This function is unavailable while recording.

ACCESS VIA THE FUNCTION BUTTON

This function can be assigned to an function button.

Assigning a function to one of the function buttons

→ See p. 74

Accessing the enlargement function

→ Press the function button

- An enlarged image section appears. The position of the enlargement depends on the position of the AF frame.
- The rectangle within the frame at the top right represents the current magnification, as well as its position in the displayed cropped section.
- The enlargement starts at the 1st of 3 enlargement increments.

Adjusting the enlargement function

→ Turn the thumbwheel/right dial

Changing the position of the enlarged section

→ Move the position of an enlarged cropped section by swiping

or

→ Press the joystick in the relevant direction

Exiting the enlargement function

→ Tap the shutter button

Note

- The enlargement function remains active until it is exited.

DISTANCE DISPLAY

Distance information is shown in the top display during manual focusing.

- Focus Mode MF: when the shutter button is pressed to the first pressure point
- Focus Mode AF: when the shutter button is pressed and held at the first pressure point, followed by a turning of the focus ring

The unit of measure (m or ft) can be selected, see p. 83.

Note

- The focus distance is estimated based on the focus position transmitted by the lens.

FOLLOW FOCUS

This function facilitates automatic transitions to specified focus settings (focus positions). Up to three such focus positions can be pre-configured and optionally be set up with a delay time. When a focus position is accessed, the camera will automatically focus on the set distance. The transition will then be achieved smoothly and with a configurable speed. That way, soft, almost unnoticeable transitions are created. Prerequisite is that the relevant distances are known beforehand.

The specified focus positions can be accessed individually or in an automated sequence.

- Select **Focus Mode** in the main menu
- Select **Follow Focus**
- Select **Focus Position**
 - “Follow Focus” is activated. The Follow Focus menu appears.

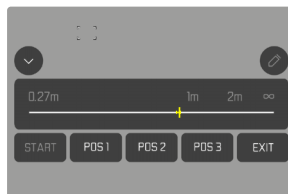

- The Follow Focus menu remains visible until the function is exited.

FUNCTION BEHAVIOR

The function continues to run regardless of whether the camera is currently recording. All operating procedures described in the following can therefore also occur while actively recording. It is also possible to start and stop a recording during an active focus sequence, or to exit the Follow Focus menu while recording.

Notes

- The following limitations apply while the function is active:
 - Depending on their assignments, some function buttons may be unavailable.
 - EVF is unavailable.
- **Follow Focus** is not available under the following conditions:
 - Recordings in slow motion
 - When using a lens adapter
 - When using MF lenses
 - When using lenses with AF/MF switch if the MF setting is selected

FOLLOW FOCUS MENU

All operation is done via touch control only.

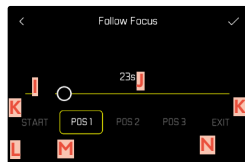
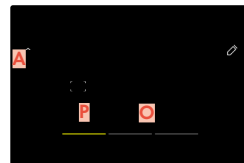
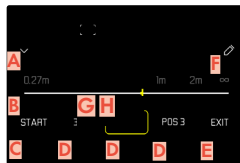

- A** Button for expanding/reducing the Follow Focus menu
- B** Focus position settings bar (Sharp focus in m or ft)
- C** "START" button (initiates the automatic focus sequence)
- D** Focus positions
- E** "EXIT" button (exits the Follow Focus menu)
- F** "Edit" button (only for pre-configured focus positions)
- G** Display of the set distance
- H** Display of the distance range in clear focus (Depth of field range, depending on the in-focus distance and the exposure value)
- I** Delay time settings bar
- J** Set delay time
- L** "Back" button
- M** Currently selected focus position
- N** "Confirm" button
- O** Running delay time
- P** Currently set focus position

The Follow Focus menu can be reduced to essential elements for better visibility.

- Tap button **A**
 - The Follow Focus menu toggles between full and reduced view.

Note

- Focus positions cannot be selected directly in reduced view.

PREPARATION

CONFIGURING A FOCUS POSITION

- Tap the desired focus position
 - The delay time settings menu appears.

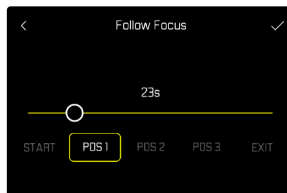

Setting a delay time

Delay times up to 120 s can be set (default setting is 0 s).

- Tap the desired setting directly via the settings bar
 - The selected time is displayed above the settings bar.
- Tap the “Confirm” button
 - The distance settings menu appears.

Setting the distance

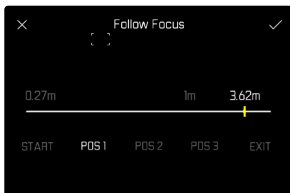

- Select the desired distance
 - Focusing can be done manually or via AFs (joystick/Touch AF). The shutter button remains locked.
 - The settings bar displays the set distance.
- Tap the “Confirm” button
 - The display returns to the top level of the Follow Focus menu.

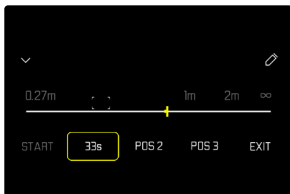

- The settings bar displays the set distance.
- The set delay time is displayed instead of POS 1, POS 2 or POS 3.

Canceling the setting

- Tap the “Back” button
 - The display reverts to the previous menu level.

CHANGING THE FOCUS POSITION

- Tap the desired button
 - The “Edit” button appears.

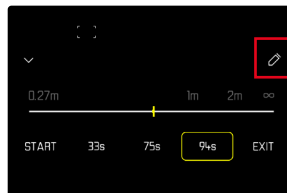

- Tap the “Edit” button
 - Any running delay time or focus setting is canceled.
 - The delay time settings menu appears.
- Define a new focus position

USE

The **Follow Focus** function can be utilized in two ways.

- The pre-configured focus positions are accessed individually as needed.
- All configured focus positions are selected automatically in sequence.

Both methods can also be combined.

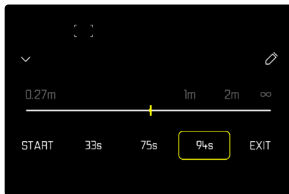

ACCESS AS NEEDED

The configured focus positions can be accessed any number of times.

With delay time:

- The active delay time is displayed in Yellow and counts down.
- After that, the transition to the next desired focus position begins.

Without delay time:

- The transition to the next desired focus position is immediate.

→ Tap the desired focus position

- The camera focuses with the set speed on the configured distance (once the delay time has elapsed - if set).

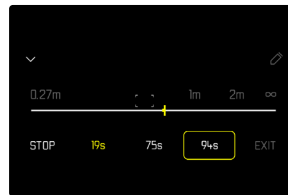

Note

- The transition to a focus position can be canceled via the "STOP" button, as long as it is not yet completed.

AUTOMATIC SEQUENCE

An automatic sequence of focus positions can be initiated if at least two positions have been configured.

START

- Configure at least two focus positions
- Tap the “START” button
 - The “START” button becomes “STOP” for the duration of the sequence.
 - All configured focus positions will be accessed in sequence (once the set delay time has elapsed - if any).
 - All other buttons are deactivated while the focus sequence runs.

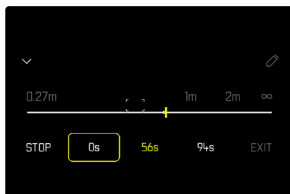

Note

- The automatic focus sequence can be run any number of times. The focus sequence will automatically revert to the first position when it is restarted.

CANCEL

- Tap the “STOP” button
 - The running focus sequence is canceled.

Initiating the automatic focus sequence directly at the beginning of the recording

The automatic focus sequence can be initiated directly at the beginning of the recording.

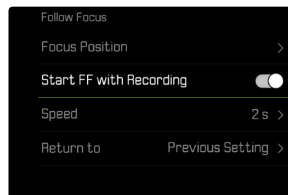

- Select **Focus Mode** in the main menu
- Select **Follow Focus**
- Select **Start FF with Recording**
- Select **On**

Exiting the function

- Canceling a running sequence
- Tap the “EXIT” button
 - The “EXIT” button is unavailable while a focus sequence is running.

OTHER SETTINGS

SPEED

The speed at which one focus position transitions to the next can be configured. This setting will then apply for all transitions.

Factory setting: 2 s

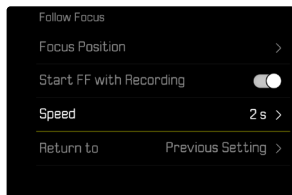

- Select **Focusing** in the main menu
- Select **Focus Mode**
- Select **Follow Focus**
- Select **Speed**
- Select the desired setting
(10 s, 4 s, 2 s, 1 s, 1/2 s)

SUBSEQUENT FOCUS MODE

After exiting, you can switch automatically to a pre-configured focus mode (e.g. MF) or to the most recently used focus mode.



- Select **Focusing** in the main menu
- Select **Focus Mode**
- Select **Follow Focus**
- Select **Return to**
- Select the desired setting
(Intelligent AF, AFs, AFc, MF, Previous Setting)

ISO SENSITIVITY (Video mode)

The ISO setting covers a total range from ISO 50 to ISO 200,000, allowing precise adjustments to various shooting conditions.

When using manual exposure, automatic ISO offers additional flexibility for achieving the desired combination of shutter speed and aperture. Within the automatic setting, priorities can be defined.

Factory setting: **ISO 100**

Note

- The available ISO range depends on the selected profile:
 - Normal (no Log): ISO 50 – 100,000
 - **L-Log**: ISO 200 – 50,000
 - **L-Log** with **Dynamic Range Boost**: ISO 400 – 50,000
 - **HLC**: ISO 400 – 100,000

FIXED ISO VALUES

The user can select ISO values between 50 and 100,000. Manual ISO settings selection is performed in increments of 1/2 EV, 1/3 EV, or 1/6 EV, depending on the **ISO Increment** setting. The number of available ISO values varies accordingly.

Using the dial

Factory setting: Left Dial

- Turn the left dial
 - The ISO value display changes accordingly in the top display and on screen.

Note

- The actually available ISO range depends on the Video Gamma settings.

Via the Control Center

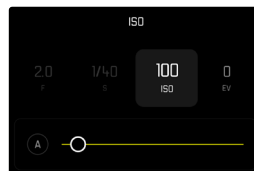
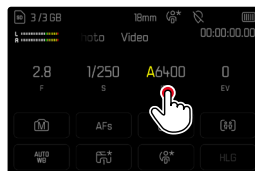

Using the function buttons

- Press and hold the desired function button
- Select **ISO**
- Select the desired setting

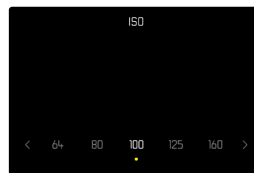
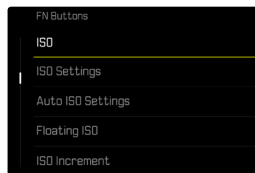

Note

- When high ISO values are used or the image is edited later, image noise, as well as vertical and horizontal stripes may become visible, particularly in larger, evenly lit areas of the object.

AUTOMATIC SETTING

Sensitivity is adjusted automatically to match the ambient brightness or the selected shutter speed/aperture combination. The range of automatic exposure control is further extended when combined with Aperture-Priority Mode.

The automatic adjustment of the ISO sensitivity is done in increments of 1 EV, 1/2 EV, 1/3 EV, or 1/6 EV, depending on the **ISO Increment** setting.

Via the Control Center

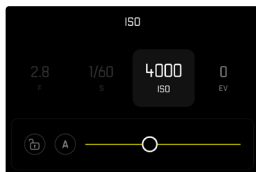
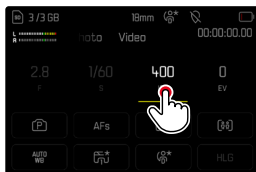

Using the function buttons

- Press and hold the desired function button
- Select **ISO**
- Select the desired setting

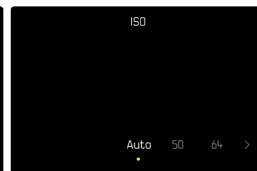
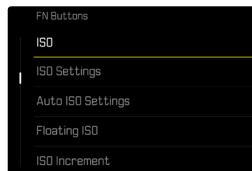

- Select **ISO** in the main menu
- Select **Auto ISO**

Notes

- This function is not available in Cine mode.
- Available options: 1 EV, 1/2 EV, 1/3 EV, 1/6 EV. (Factory setting: 1/6 EV)

LIMITING SETTING RANGES

A max. ISO value can be set, which will then limit the automatic setting range (Max. ISO value). A max. exposure time can also optionally be configured. There are automatic settings and fixed max. shutter speeds $1/30$ s and $1/2000$ s available for that purpose.

LIMITING ISO VALUES

All values from ISO 200 are available.

Factory setting: 6400

- Select **ISO Settings** in the main menu
- Select **Auto ISO Settings**
- Select **Maximum ISO**
- Select the desired value

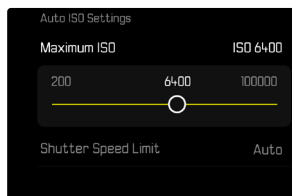

LIMITING SHUTTER SPEED RANGES

Factory setting: **Auto**

- Select **Auto ISO Settings** in the main menu
- Select **Shutter Speed Limit**
- Select the desired value
(Auto, $1/2000$, $1/1000$, $1/500$, $1/250$, $1/125$, $1/60$, $1/30$)

Note

- When set to **Auto**, the shutter speed is selected automatically based on the sensor format:
 - 35 mm: approx. $1/(2 \times \text{focal length})$
 - APS-C: approx. $1/(3 \times \text{focal length})$
- The actual shutter speed used similarly depends on the **ISO Increment**.

DYNAMIC ISO SETTING

The thumbwheel and right dial can be configured to allow manual ISO settings in real time. That is the factory setting in the operating modes **S**, **A** and **M**. Turning the dial will cycle through all setting values available in the **ISO** menu. That means that **Auto ISO** can also be selected.

FLOATING ISO

This function complements Auto ISO. Light strength changes with many zoom lenses when the focal length is changed. Floating ISO will in this situation adjust the sensitivity in fine graduations and will simultaneously ensure that the selected settings of aperture value and shutter speed remain constant in (semi) automatic exposure modes. This will specifically in video shootings prevent visible jumps in brightness.

Factory setting: **On**

→ Select **Floating ISO** in the main menu

→ Select **On**

Notes

- **Floating ISO** can work only if the original ISO setting allows scope for change, i.e. the highest/lowest ISO setting is not already being used. The **Floating ISO** warning icon will be displayed in that case.
- This function is not available in Cine mode.

ASA SENSITIVITY (Cine-Mode)

The sensitivity setting in Cine mode is always done manually. The menu item **ASA** replaces the menu item **ISO**. The value is stated in ASA units. Automatic settings (**Auto ISO**/**Floating ISO**) are unavailable.

Factory setting: **100**

Via the Control Center

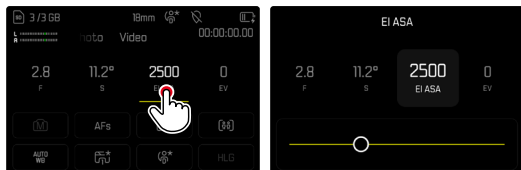

Using the function buttons

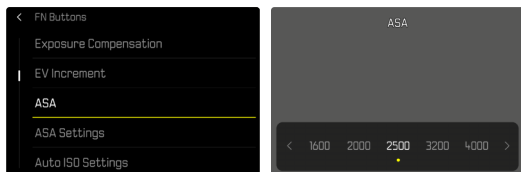

- Press and hold the desired function button
- Select **ASA**
- Select the desired setting

WHITE BALANCE

In digital photography, White Balance ensures neutral color rendering in any light. White Balance relies on the setting made in the camera, which light color is to be rendered as 'white'.

Four methods are available:





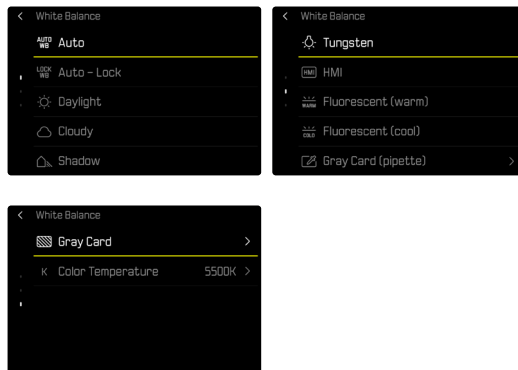

- automatic control with lock function
- fixed presets
- manual setting via metering
- direct setting of the color temperature

Factory setting: **Auto**



AUTOMATIC CONTROL/FIXED SETTINGS



- **Auto**: for automatic control, which delivers neutral results in most situations
- Various fixed presets for most frequently encountered light sources:

| | | |
|--|---------------------------|---|
|  | Daylight | For outdoor shootings in sunlight |
|  | Cloudy | For outdoor shootings in cloudy conditions |
|  | Shadow | For outdoor shootings with the main subject in shadow |
|  | Tungsten | For indoor shootings with (predominantly) incandescent lamp light |
|  | HMI | For indoor shootings with (predominantly) light from metal halide lamps |
|  | Fluorescent (warm) | For indoor shootings with (prevailing) light from fluorescent tubes with warm light color |
|  | Fluorescent (cool) | For indoor shootings with (prevailing) light from fluorescent tubes with cool light color |

- Select **White Balance** in the main menu
- Select the desired setting

MANUAL SETTING VIA METERING

 **Gray Card**/ **Gray Card (pipette)**

This metering variant captures all color hues in the metering field and uses these to calculate a mean gray value. The variant  **Gray card** is suited best for subjects in which you can clearly identify a neutral gray or pure white area. If that is not the case, or should you wish to base your metering on an off-center detail, then  **Gray Card (pipette)** will be a better choice.

Note

- A value configured using this method will remain unchanged (i.e. it will be used for all subsequent photographs) until new measurements are taken or one of the other white balance settings is selected.

GRAY CARD (PIPETTE)

This metering variant captures only the color hue metered within the metering field and calculates the mean gray value from it.

- Select **White Balance** in the main menu
- Select **Gray Card (pipette)**
 - The following appears on the LCD panel:
 - the image based on automatic white balance
 - a cross in the middle of the image

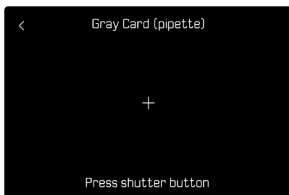

- Aim the metering field at a white or neutral gray area

Repositioning the focus frame

- Press the joystick in the relevant direction

Performing measurement

- Shutter release

or

- Press the joystick/thumbwheel
 - The measurement is taken.

Cancelling measurements

- Press the **FN** button

GRAY CARD

This metering variant captures all color hues in the metering field and uses these to calculate a mean gray value.

- Select **White Balance** in the main menu
- Select **Gray Card**
 - The following appears on the LCD panel:
 - the image based on automatic white balance
 - a frame in the center of the image

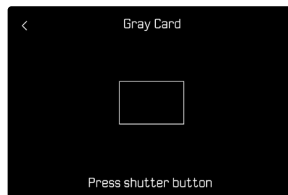

- Aim the metering field at a white or neutral gray area
 - The screen image changes dynamically in line with the reference area in the frame.

Performing measurement

- Shutter release

or

- Press the joystick/thumbwheel
 - The measurement is taken.

Cancelling measurements

- Press the **FN** button

DIRECT SETTING OF THE COLOR TEMPERATURE

Values between 2000 and 11500 K (Kelvin) can be set directly. That gives you a very wide range, which covers virtually all color temperatures occurring in real life and within which you can adapt color rendering to any light color and your personal preferences with incredible detail.

Factory setting: **5500 K**

- Select **White Balance** in the main menu
- Select **Color Temperature**
- Select the desired value

EXPOSURE

The exposure setting is done dynamically via the two assigned dials. Function assignments can be modified, see p. 75.

Exposure settings can be done quickly and easily via the Control Center.

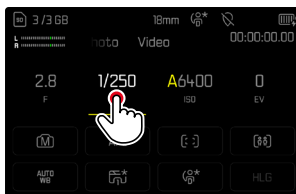





- Tap the desired control panel
 - The active control panel is highlighted in gray.
 - A setting band appears instead of the menu items. A dot marks the current setting. The current setting value is displayed above the dot.
- Tap the setting band briefly in the desired position, or drag the dot to the desired position

EXPOSURE METERING METHODS

The following exposure metering methods are selectable.

Factory setting: **Multi-Field**

-  Spot
-  Center-weighted
-  Highlight-Weighted
-  Multi-field

- Select **Exposure Metering** in the main menu
- Select the desired metering method (**Spot**, **Center-Weighted**, **Highlight-Weighted**, **Multi-Field**)
 - The selected metering method is displayed in the header line of the screen image.

Spot metering allows a shifting of the focus point.

- Press the joystick in the relevant direction

Notes

- The exposure information (ISO value, aperture, shutter speed and light balance with exposure compensation scale) will help to determine the settings required for correct exposure.
- The most important displays (ISO value, aperture and shutter speed) will also appear in the top display.

SPOT

This metering method is concentrated exclusively on a small area in the center of the image. The metering fields are joined together when the exposure metering method **Spot** is combined with the AF metering methods **Spot**, **Field** and **Zone**. Exposure metering will then occur at the point specified by the AF frame, even if it is moved.

CENTER-WEIGHTED







This method considers the entire image field. The subject elements captured in the center will, however, impact on the calculation of the exposure value more so than areas around the edges.

MULTI-FIELD

This metering method is based on the detection of multiple values. These values are used in an algorithm to calculate an exposure value appropriate for a good rendering of the assumed main subject.

HIGHLIGHT-WEIGHTED

This method considers the entire image field. The exposure value will, however, be adjusted to very bright subject elements. That prevents the overexposure of bright subject elements without having to measure them individually. This metering method is particularly useful for objects that are significantly more brightly lit than the rest of the frame (e.g. people in a spotlight), or that reflect the light significantly (e.g. white clothing).

| Multi-field | Highlight-weighted |
|--|---|
|  |  |
|  |  |
|  |  |

EXPOSURE MODES

You can choose one of four video shooting modes:

- Program AE mode (**P**)
- Aperture-priority mode (**A**)
- Shutter-priority mode (**S**)
- Manual setting (**M**)

Cine mode also offers another, fully manual mode.

Notes

- When using a lens with an aperture ring (e.g. Leica M lenses), only the exposure modes **A** (aperture-priority) and **M** (manual setting) will be available. Where that is the case, **F0.0** is displayed as the aperture value.
- The following applies for all exposure modes: the available shutter speeds for custom settings or those available for automatic settings depend on the selected frame rate (**Video Resolution**, see p. 192).
- When Auto ISO is active, the camera uses the dynamic adjustment function for the ISO value for the exposure setting. Depending on the exposure mode selected, the automatic ISO setting interacts with automatically controlled aperture and/or shutter speed settings.

SELECTING A MODE

Via the thumbwheel

- Press the thumbwheel
 - The currently selected mode is shown in the top display. The currently selected mode is marked in red on screen.
- Turn the thumbwheel to select the desired mode
 - The mode display changes in the top display and on screen. All modes can be reached by turning the wheel in either direction.
 - The selected mode will be applied automatically approx. 2 s after the thumbwheel is moved the last time.



Via the Control Center

→ Tap the control panel



→ Tap the desired exposure mode

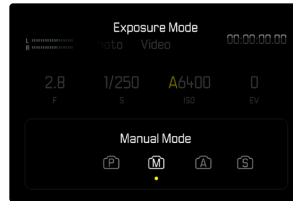

Applying the selected mode immediately

- Press the joystick/thumbwheel
- or
- Tap the shutter button

FULLY AUTOMATIC EXPOSURE SETTING – P SEMI-AUTOMATIC EXPOSURE SETTING – A/S

PROGRAM AE MODE – P

The exposure is controlled by an automatic shutter speed and aperture setting.

The exposure compensation and recording level are controlled directly via the dials.

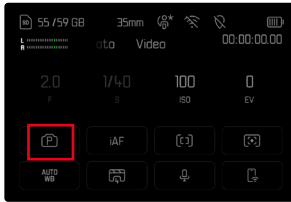

- Select the operating mode **P**
- Set exposure compensation as needed
- Start video recording

Note

- Automatic exposure control takes into account any fluctuations in brightness. Set the shutter speed manually if this is undesirable, e.g. for landscape recordings or panning.

APERTURE-PRIORITY MODE- A

Aperture-priority mode sets the exposure automatically according to the manually selected aperture. It is therefore specifically suitable for video recordings in which the depth of field is a critical compositional element.

The range of the depth of field can be diminished with an accordingly small aperture value. This will set off the focused area against the unfocused background. Conversely, a greater aperture value will increase the range of the depth of field. Such a setting is advisable if the foreground and background should be rendered in sharp focus.

The selected aperture setting will be maintained for the duration of the recording.

- Select the operating mode **A**
- Set the desired aperture value
- Start video recording

SHUTTER-PRIORITY MODE – S

Shutter-priority mode will set exposure automatically according to the manually selected shutter speed. The selected shutter speed will be maintained for the duration of the recording.



- Select the operating mode **S**
- Set the desired shutter speed
- Start video recording

MANUAL EXPOSURE SETTING – M

The following manual settings for shutter speed and aperture are a good choice:

- to maintain constant exposure settings between multiple recordings
 - to maintain constant exposure settings while recording, specifically in conjunction with fixed ISO settings
- Select the operating mode **M**
- Select desired exposure
- The exposure compensation is done using the scale of the light balance.
- Start video recording

Displays on the light balance:

| | |
|--|--|
|  | Correct exposure |
|  | Underexposure or overexposure by the displayed value |
|  | Underexposure or overexposure by more than 3 EV (Exposure Value) |

EXPOSURE COMPENSATION

Exposure compensation values can be set in the range ± 3 EV (EV: Exposure Value). The available values depend on the global setting **EV Increment**.

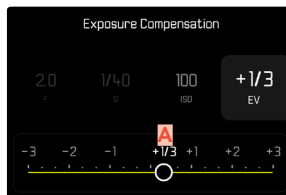

A Set compensation value (marks at 0 = Off)

- Select **Exposure Compensation** in the main menu
- A scale appears as a submenu item on the LCD panel.
- Set the value on the scale
- The set value is displayed above the scale.
 - While setting the value, you can see the effect on the screen image, which becomes darker or lighter.

Notes

- This function is assigned to one of the dials in the three (semi) automatic exposure modes, making it easily accessible.
- The set exposure compensation is indicated by a mark on the exposure compensation scale in the footer line.
- The following applies for set compensation values, no matter how they were initially set: They remain effective until they are manually reset to 0, even if the camera is switched off and on again in the meantime.
- Changes to the **EV Increment** setting lead to the cancellation of a compensation that has been set, i.e. in such cases it is automatically reset to 0.

FULLY AUTOMATIC EXPOSURE SETTING – P

PROGRAM AE MODE – P

The exposure is controlled by an automatic shutter speed and aperture setting.

The exposure compensation and recording level are controlled directly via the dials.



→ Select the operating mode **P** (see p. 262)

→ Set exposure compensation as needed

→ Start video recording

Note

- Automatic exposure control takes into account any fluctuations in brightness. Set the shutter speed manually if this is undesirable, e.g. for landscape recordings or panning.

SEMI-AUTOMATIC EXPOSURE SETTING

– A/S

APERTURE-PRIORITY MODE- A

Aperture-priority mode sets the exposure automatically according to the manually selected aperture. It is therefore specifically suitable for video recordings in which the depth of field is a critical compositional element.

The range of the depth of field can be diminished with an accordingly small aperture value. This will set off the focused area against the unfocused background. Conversely, a greater aperture value will increase the range of the depth of field. Such a setting is advisable if the foreground and background should be rendered in sharp focus.

The selected aperture setting will be maintained for the duration of the recording.

→ Select the operating mode **A** (see p. 262)

→ Set the desired aperture value

→ Start video recording

SHUTTER-PRIORITY MODE – S

Shutter-priority mode will set exposure automatically according to the manually selected shutter speed. The selected shutter speed will be maintained for the duration of the recording.

→ Select the operating mode **S** (see p. 262)

→ Set the desired shutter speed

→ Start video recording

MANUAL EXPOSURE SETTING – M

The following manual settings for shutter speed and aperture are a good choice:

- to maintain constant exposure settings between multiple recordings
 - to maintain constant exposure settings while recording, specifically in conjunction with fixed ISO settings
- Select the operating mode **M** (see p. 262)
- Select desired exposure
- The exposure compensation is done using the scale of the light balance.
- Start video recording

Displays on the light balance:

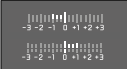
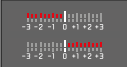
| | |
|---|--|
|  | Correct exposure |
|  | Underexposure or overexposure by the displayed value |
|  | Underexposure or overexposure by more than 3 EV (Exposure Value) |

EXPOSURE COMPENSATION

Exposure compensation values can be set in the range ± 3 EV (EV: Exposure Value). The available values depend on the global setting **EV Increment** (see p. 216).

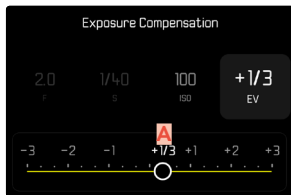

A Set compensation value (marks at 0 = Off)

- Select **Exposure Compensation** in the main menu
 - A scale appears as a submenu item on the LCD panel.
- Set the value on the scale
 - The set value is displayed above the scale.
 - While setting the value, you can see the effect on the screen image, which becomes darker or lighter.

Notes

- This function is assigned to one of the dials in the three (semi) automatic exposure modes and therefore quickly accessible (see p. 75).
- The set exposure compensation is indicated by a mark on the exposure compensation scale in the footer line (see p. 30).
- The following applies for set compensation values, no matter how they were initially set: They remain effective until they are manually reset to **0**, even if the camera is switched off and on again in the meantime.
- Changes to the **EV Increment** setting (see p. 216) lead to the cancellation of a compensation that has been set, i.e. in such cases it is automatically reset to **0**.

COMPENSATION PROFILES FOR ANAMORPHIC LENSES

Anamorphic lenses capture a particularly wide field of view by horizontally compressing the subject on the sensor (squeeze). This process facilitates the classic cinema aspect ratio and creates the characteristic cinematic look.

The new **Lens Profiles** correct this image compression directly in-camera during playback, so that the preview image in the viewfinder or display is shown in the correct aspect ratio. This allows the subject to be assessed precisely during shooting – perfect for professional film productions using anamorphic optics.

- Select **Camera Settings** in the main menu
- Select **Lens Profiles**
- Select the desired setting
(1.25, 1.3, 1.33, 1.5, 1.6, 1.65, 1.8, 1.85, 2.0)

Notes

- This function is available only when using anamorphic lenses in Video mode.
- The menu option remains grayed out if no anamorphic lens is attached. Please mount a manual anamorphic lens to allow the activation of this option.

PLAYBACK MODE

Playback mode is used to display and manage the stored recordings. The switchover between shooting and playback mode, as well as most other actions can be completed using gesture or key control. Please see p. 59 for more information about the available gestures.

Notes

- Recorded videos are not automatically rotated in playback mode to utilize the full screen area.
- It may not be possible to render files with this camera that were not recorded with this device.
- In some cases, the screen image may not have the expected quality, or the LCD panel will remain blank and only display the file name.
- You can toggle back from playback mode to shooting mode at any time by tapping the shutter button.

CONTROL ELEMENTS IN PLAYBACK MODE

CONTROL ELEMENTS ON THE CAMERA

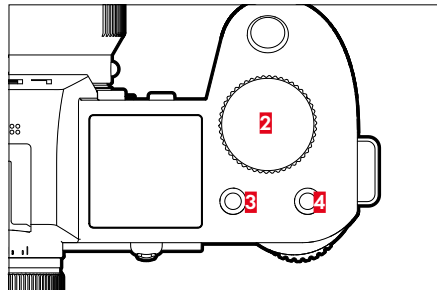
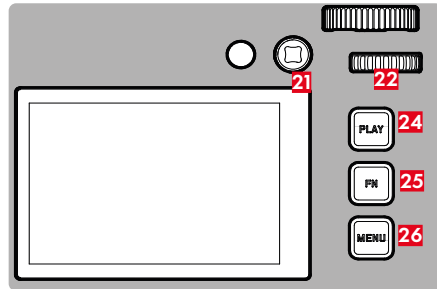

- | | |
|--------------------------|--------------------------------------|
| 2 Right dial | 22 Thumbwheel (turn or press) |
| 3 Function button | 24 PLAY button |
| 4 Function button | 25 FN button |
| 21 Joystick | 26 MENU button |

DIRECT ACCESS IN PLAYBACK MODE

The function buttons can have individual assignments in playback mode as well.

In factory settings, the function buttons have the following assignments:

| Button | Function |
|---------------------|----------------------------|
| Right dial | Magnification |
| Function button (3) | Delete Single |
| Function button (4) | Mark shots (Rate / Unrate) |
| FN button | Toggle Info Levels |

The descriptions in the next few sections presume factory settings.

Notes

- The assigned function is independent of the current display mode; the delete functions overview can therefore be accessed directly in full screen display mode.
- The assigned function is unavailable if the function button addresses an on-screen control element (e.g. in the "Delete" screen).

CONTROL ELEMENTS ON THE LCD PANEL

On-screen control elements generally function by intuitively by touch. Many can also be selected by pressing one of the three buttons to the right of the LCD panel (**PLAY** button, center button, **MENU** button). A control element in the header is accompanied by an icon denoting the relevant button. A control element on the edge of the screen will be positioned directly next to the relevant button.

You have e.g. two options to select the Favorites icon ★:

- Tap on the Favorites icon directly
- press the relevant button (Factory setting: Function button (4))

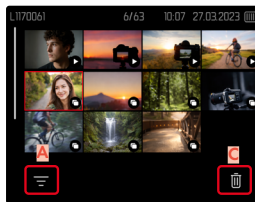

- A** Control element "Filter"
- B** Control element "Favorites"
- C** Control element "Delete"

STARTING/EXITING PLAYBACK MODE

Using touch control

→ Swipe down

Shooting



Playback



Using button control

→ Press the **PLAY** button

- The last image taken appears on the screen.
- The message **No valid video to play** appears if the inserted memory card does not contain any recording data.
- The **PLAY** button function differs, depending on the current camera setting

| Initial situation | After pressing the PLAY button |
|--|---------------------------------------|
| Full screen display of a recording | Shooting mode |
| Display of an enlarged cropped section/or several thumbnails | Full screen display of the image |

SELECTING/SCROLLING THROUGH RECORDINGS

The images are visually arranged in a horizontal reel. The sorting will be strictly chronological. When the end of an image series is reached, the display automatically jumps back to the first image in the series. All recordings can therefore be reached by scrolling either right or left.

SINGLE

Using touch control

→ Swipe to the left or right

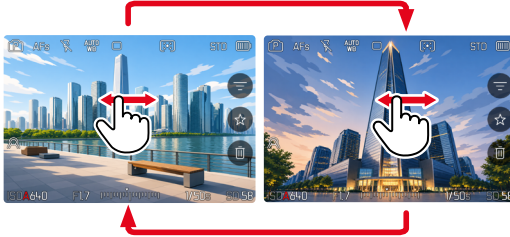

Using button control

→ Press the joystick left/right

or

→ Turn the thumbwheel

CONTINUOUS

- Swipe to the left or right and hold the finger on the edge of the screen
 - The subsequent shots will move past continuously.

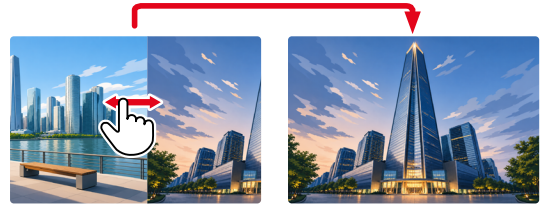

STORAGE LOCATIONS

Leica SL3-P offers with two separate storage locations. When playback mode is accessed, the last captured image will always be displayed first. That also applies on the storage location displayed first.

When scrolling through images and also in the over-view, the images saved to the same storage location are available first.



Switching the displayed storage location

- Reduce the view as much as possible (see p. 274)
 - The storage location selection view appears.
 - The currently selected storage location is displayed with a color fill.



- Press the directional pad left/right
 - The newly selected storage location appears with a color frame.
- Press the center button
- Re-enlarge the view

INFO DISPLAYS IN PLAYBACK MODE

The same info profiles are available in playback mode as in shooting mode. The actual info profile currently in use, however, is saved separately. It is therefore possible to use an empty info profile completely without assist function icons in playback mode, without having to set them again when switching to shooting mode. The assist functions **Grids**, **Level Gauge**, **Framelines**, **False Color** or **Waveform Monitor** are not available in playback mode.

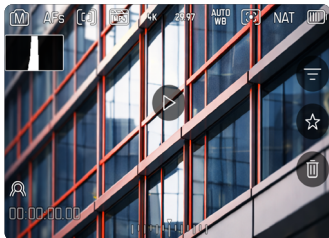

Info Bars

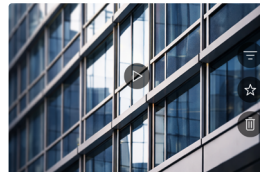

Empty info profile

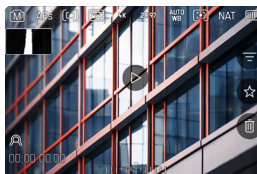

Info Bars, Focus Peaking,
Histogram



Info Bars, file information

Switching between info profiles

- Press the **FN** button
 - The info bars appear (header and footer line always appear/disappear together in playback mode).
 - Where the options **Histogram** (**Luminance** only) and **Clipping** are selected, these displays will also be visible.

DISPLAYING MULTIPLE IMAGES AT ONCE

The camera offers an overview function in which several thumbnail images can be viewed on one screen, which makes it easier to find a specific image. Choose to display 9 or 16 thumbnails for your overview.

OVERVIEW

Using touch control



- Two-finger pinch
 - The display toggles between 9 or 16 thumbnails.

Viewing other recording

- Swipe up or down

Using button control

- Turn the right dial in anti-clockwise direction
 - An overview with 9 thumbnails is displayed.
 - Another turn on the dial increases the number of displayed thumbnails to 16.



- A** Currently selected recording
- B** Number of the currently selected recordings
- C** Scrollbar

The currently viewed recording is framed in red and can be selected for a closer look.

Navigating between recordings

→ Press the joystick in the relevant direction

or

→ Turn the thumbwheel

Displaying the recording in full size

Using touch control

→ Two-finger spread

or

→ Tap the desired recording

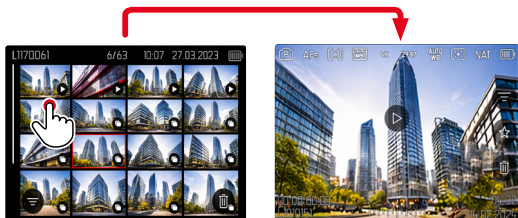

Using button control

→ Turn the right dial in clockwise direction

or

→ Press joystick, thumbwheel or **PLAY** button

TAGGING/RATING OF RECORDINGS

Recordings can be marked as favorites to find them quicker or to simplify the later deletion of multiple recordings. Tagging can be done in regular view mode or in the overviews.

Tagging a recording

→ Press the function button 

or



→ Tap the ★ icon

- The ★ icon is highlighted.
- The icon will appear in the header on the far right when viewing recordings in full size, and in the lower left corner of the thumbnail overview.

Removing a tag

→ Press the function button 

or

→ Tap the ★ icon

DELETING RECORDINGS

There are several methods available to delete recordings:

- deleting individual recordings
- deleting multiple recordings
- deleting all recordings without a icon/ranking
- deleting all recordings

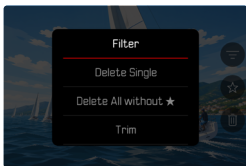

Important

- Once deleted, recordings are no longer retrievable.

DELETING INDIVIDUAL RECORDINGS



- Tap the Delete  icon
 - The recording will be deleted without additional confirmation prompt.
 - The LED will flash during the delete process. The process may take a few seconds.
 - The next recording will be displayed once deletion is complete. The message **No valid video to play** appears if no other recordings are saved on the card.

or

- Press the function button 
 - The Delete screen appears.

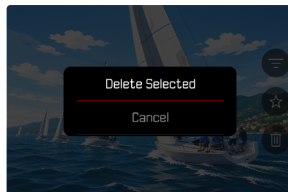

Cancelling a deletion and returning to normal playback mode

→ Press the **PLAY** button

Notes

- The Delete screen can be called up only by pressing the **MENU** button when in overview mode, because the menu function **Delete** of the “Play menu” is not available in this context.
- The “Scroll” and “Magnify” functions will always be available, even if the “Delete” screen is active.

DELETING MULTIPLE RECORDINGS

You can highlight multiple recordings in a Delete overview with twelve thumbnails for simultaneous deletion.

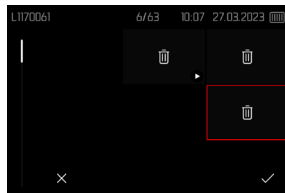

- Turn the right dial to the left
 - The overview screen appears.
- Press the **MENU** button
- Select **Delete Multi**
 - The Delete overview appears.

Any number of recordings can be selected in this view.

Selecting recordings for deletion

- Select a recording
- Press the joystick/thumbwheel

or

- Tap the desired recording
 - The recordings selected for deletion are marked with a red Delete icon .

Deleting the selected recordings

- Press the **MENU** button

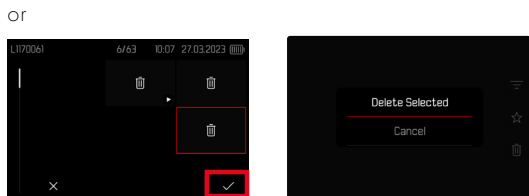

- Tap the “Confirm” icon
- Select **Delete Selected**
 - The recordings selected for deletion are marked with a red Delete icon .

Cancelling a deletion and returning to normal playback mode

- Press the **MENU** button

DELETING ALL UNRATED RECORDINGS

- Press the **MENU** button
- Select **Delete All without ★**

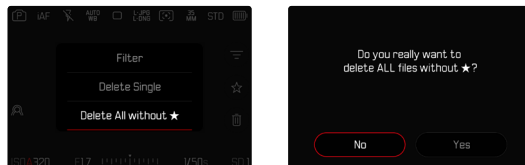

- The confirmation prompt **Do you really want to delete ALL files without ★?** appears.
- Select **Yes**
 - The LED will flash during the deletion process. The process may take a few seconds. The next marked recording appears once deletion is complete. The message **No valid video to play** appears if no other recordings are saved on the card.

PAUSE PLAYBACK

- Tap anywhere on the LCD panel
- or
- Press the joystick/thumbwheel

RESUMING PLAYBACK

Using touch control

While the control elements are visible:

- Tap anywhere on the LCD panel

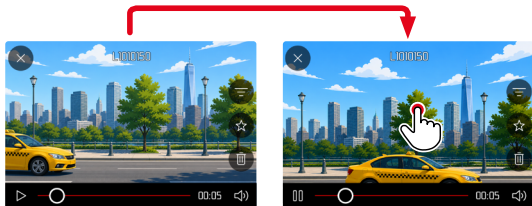

NAVIGATE TO ANY POINT IN THE FILE

QUICK JUMP

Using touch control

While the control elements are visible:

- Tap the Playback status bar at the desired position

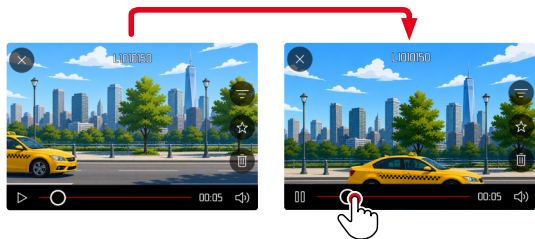

Using button control

- Press and hold the joystick left/right

Using button control

While the control elements are visible:

- Press the joystick/thumbwheel

PRECISE SELECTION

- Turn the thumbwheel

END PLAYBACK

Using touch control

While the control elements are visible:

→ Tap the “Go back” icon ↶

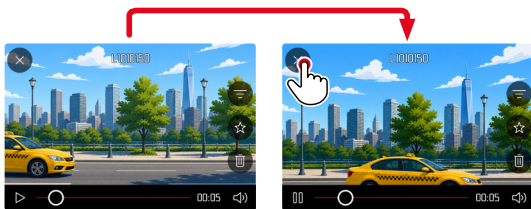

Using button control

→ Press the **PLAY** button

SETTING THE VOLUME

Using touch control

While the control elements are visible:

→ Tap the volume icon

→ Tap the volume bar at the desired position

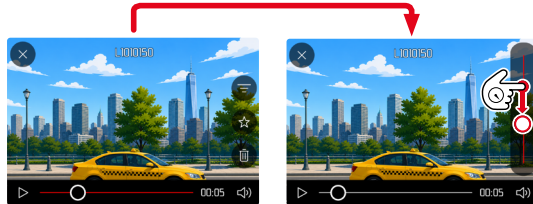

Using button control

→ Press the joystick up/down

- The volume bar appears.

→ Press the joystick up (louder) or down (quieter)

Note

- Sound is switched off at the lowest part of the bar and the volume icon changes to .

VIDEO EDITING

Using button control



ACCESSING THE VIDEO EDITING FUNCTION

- Press the **MENU** button
- Select **Video Trimming**
 - The video cutting screen appears, the left cutting mark is highlighted in red (= active).

CHANGING THE CURRENT CUTTING POINT

- Press the joystick left/right
 - The selected cutting point is highlighted in red (= active).

MOVING THE ACTIVE CUTTING POINT

- Turn the thumbwheel
 - The currently selected time of the relevant cutting point is displayed at the bottom left of the footer line. A still of the video sequence at that point is displayed in the background.

CUTTING

- Press the thumbwheel or the joystick to confirm the cuts
 - The **Video Trimming** menu appears.
- Select a function from the **Video Trimming** menu (**Save as new**, **Overwrite**, **Preview**)

| | |
|--------------------|---|
| Save as new | The new video is additionally saved, the original video remains unchanged. |
| Overwrite | The newly cut video is saved and the original one is deleted. |
| Preview | The new video is played. The newly cut video is not saved and the original remains unchanged. |

CANCELLING THE VIDEO EDITING FUNCTION

The editing function can be canceled at any time, provided no selection was made in the **Video Trimming** menu.

- Press the **PLAY** button
 - The video playback screen reappears.

Notes

- In all three cases, a notification screen appears while the data is being processed. Then the new video is played back.
- The numbering of existing recordings will not be changed when **Save as new** is selected. The newly created video will be added to the end of the series of videos.

HDMI SETTINGS

HDMI-related settings have now been consolidated into their own menu group. **HDMI Audio** activates/deactivates the HDMI audio output. **HDMI Resolution** specifies the HDMI output behavior (e.g. automatic adjustment or fixed resolution).

Note

- The **HDMI Audio** menu item, which was previously available as a standalone setting in the camera menu, is now part of the new HDMI Settings menu group. This centralizes all HDMI-relevant options, making them easier to access and more clearly organized.

HDMI RESOLUTION

To prevent the camera from overheating during extended use, the HDMI output resolution in Live View can be reduced automatically. In Live View, the HDMI signal is output at a reduced resolution. This adjustment occurs automatically as soon as the camera is connected via HDMI, and no recording is in progress. A corresponding notification is displayed. Once recording is started on the camera, the preset recording resolution is used and output over HDMI accordingly.

- Select **HDMI Settings** in the main menu
- Select **HDMI Resolution**
- Select the desired setting
(**Auto**, **Full**)
 - **Auto**: the Live View display is rendered with a **reduced** resolution.
 - **Full**: the Live View display is rendered with **full** resolution. A noticeable reduction in heat build-up

Note

- The reduced resolution applies exclusively to Live View operation and is intended to minimize heat buildup, particularly during extended use in conjunction with external screens or recorders.

MIRROR LCD PANEL IMAGE VIA HDMI TO EXTERNAL SCREEN

This function allows the camera's entire screen image to be output over HDMI to an external screen.

The full settings menu and a live feed with information overlays can be shown via HDMI, identical to the display on the camera LCD panel. This output is intended primarily for on-set monitoring when the HDMI port is not being used for external recording.

- Select **Camera Settings** in the main menu
- Activate/deactivate **Mirror via HDMI**.

OTHER FUNCTIONS

The settings described in this chapter apply for photo and video mode alike. They are therefore available in the picture and video menu (see chapter “Camera Operation” under “Menu Control”). A setting selected in one of the modes will also apply to the other.

RESETTING THE CAMERA TO FACTORY SETTINGS

This function allows you to reset all your custom menu settings back to the factory settings. You can optionally exclude the user profiles, Wi-Fi and Bluetooth settings, as well as the image numbering from the reset individually.

- Select **Camera Settings** in the main menu
- Select **Reset Camera**
 - The prompt **Do you want to reset the camera settings?** appears.
- Confirm **(Yes)** or reject **(No)** restoring the default settings
 - Selecting **No** will cancel the reset and the display will return to the main menu. Selecting **Yes** will trigger additional prompts regarding the settings you can opt to keep.
- Confirm **(Yes)** or reject **(No)** resetting the user profiles
- Confirm **(Yes)** or reject **(No)** the reset of the Wi-Fi and Bluetooth settings
- Confirm **(Yes)** or reject **(No)** resetting the image numbering
- Confirm **(Yes)** or reject **(No)** the reset of the LUT profiles
- Confirm **(Yes)** or reject **(No)** the reset of the Leica Looks profiles
 - The message **Please Restart the Camera** appears.
- Switch the camera off and on again

Notes

- Date & time, as well as the preferred language will have to be set up again after a reset. Relevant prompts will appear on screen.
- You reset the image numbering separately via the menu item **Reset Image Numbering** (see p. 286).

FIRMWARE UPDATES

Leica is continuously working on the further improvement and optimization of your camera. Since many camera functions are entirely controlled by software, some of these improvements and additions to the functional scope can be installed in retrospect. Leica offers firmware updates at irregular intervals, which you can download from our website.

Leica will notify you of any new updates, once you have registered your camera. Users of Leica FOTOS will also be automatically notified about firmware updates for their Leica cameras.

There are two options for installing firmware updates.

- conveniently via the Leica FOTOS app (see p. 292)
- directly via the camera menu

Finding the currently installed firmware version

- Select **Camera Information** in the main menu
 - The current firmware version is displayed next to the menu item **Camera Firmware Version**.



More information about registering, firmware updates and how to download them to your camera, as well as any amendments and additions to this manual can be found in the customer area of our website at:

<https://club.leica-camera.com>

EXECUTING A FIRMWARE UPDATE

Any interruption of a running firmware update may cause serious and irreparable damage to your equipment!

You will therefore have to take particular note of the following, when carrying out a firmware update:

- Do not switch off the camera!
- Do not remove the memory card!
- Do not remove the rechargeable battery!
- Do not detach the lens!

Notes

- A warning message will appear if the battery is insufficiently charged. Recharge the battery and then repeat the process described above.
- You will find additional device and country-specific registration marks and numbers in the **Camera Information** submenu.

PREPARATION

- Fully charge and insert the rechargeable battery
- Remove the second card (where applicable) from the camera
- Any stored firmware files on the memory card must be removed
 - We recommend saving any images on the memory card and reformatting it before the update. (Caution: Loss of data! All data stored on the memory card will be lost during formatting.)
- Download the latest firmware version
- Save the download to the memory card
 - The firmware file must be stored in the main directory of the memory card (not in a sub-directory).
- Insert the memory card into the camera
- Switch the camera on

UPDATING THE CAMERA FIRMWARE

- Preparation
- Select **Camera Information** in the main menu
- Select **Camera Firmware Version**
- Select **Firmware Update**
 - A prompt with information about the camera is displayed.
- Check the version information
- Select **Yes**
 - The prompt **Save profiles on SD Card?** appears.
- Select **Yes/No**
 - The update will start automatically.
 - The status LED will flash during this process.
 - Once the process has completed successfully, a relevant on-screen message and prompt to restart the device will appear on screen.
- Switch the camera off and on again

Note

- These settings will be applied automatically if the update is loaded via Leica FOTOS.
- Dialog messages regarding firmware updates will only be displayed on the LCD panel.

UPDATING THE LENS FIRMWARE

Where available, you can optionally carry out firmware updates for lenses. The instructions provided for camera firmware updates apply.

- Preparation
- Select **Camera Information** in the main menu
- Select **Lens Firmware Version**
- Select **Firmware Update**
 - A prompt with information about the camera is displayed.
- Check the version information
- Select **Yes**
 - The update will start automatically.
 - The lower status LED will flash during this process.
 - Once the process has completed successfully, a relevant on-screen message and prompt to restart the device will appear on screen.
- Switch the camera off and on again

CAMERA-TO-CLOUD – FRAME.IO

The camera can now connect directly to Frame.io via WLAN. With this integration, photos and proxy videos can be uploaded straight from the camera to the cloud – quickly, securely, and without any intermediate steps. This ensures that recordings are immediately available for further editing or team sharing.

A new **Connectivity** menu item was introduced for this feature, via which **Leica FOTOS** and **Frame.io** can now be configured.

- Select **Connectivity** in the main menu
- Select **Frame.io**
- Select the desired Wi-Fi network

More information about the functional scope of Frame.io:

Product Tour:

<https://lmy.de/sGcjg>



Video Tutorial

<https://vimeo.com/1143409148>



Notes

- A simultaneous connection with Leica FOTOS and Frame.io is not possible.
- To upload proxy videos, a CFe card and an SD card must be inserted simultaneously, and the Proxy option must be enabled in the video profile.
- The Frame.io function requires a certificate. This certificate is saved on the camera and valid between 2025 and 2037.

LEICA FOTOS

The camera can be controlled remotely using a smartphone/tablet PC. This will require an installation of the Leica FOTOS app on the mobile device. Leica FOTOS furthermore offers a variety of other useful functions:

- Geotagging for images
- File transfer
- Downloading firmware updates
- Self-timer delay time selection via remote control, e.g. for group photographs
- Loading and transferring Leica Looks

A list of available functions and instructions for their use can be found in the Leica FOTOS app. Please read the legal notes on page 7.

- Scan the following QR code with the mobile device



or

- The app is available from Apple App Store™/Google Play Store™

SELECTING A WI-FI BAND

Leica SL3-P supports the use of various Wi-Fi frequencies in a number of regions.

- Select **Camera Settings** in the main menu
- Select **WLAN**
- Select **Wi-Fi band**
- Select the desired setting

Note

- The menu item will appear grayed out, where this option is unavailable.

CONNECTION - iOS

FIRST-TIME CONNECTION TO A MOBILE DEVICE

The camera can be paired with a mobile device when the two devices connect for the first time.

CONNECTION WIZARD

The connection wizard appears at initial startup of the camera or after a camera reset. These settings are also available via the menu item **Leica FOTOS**.

The following screen appears after you have selected the language.

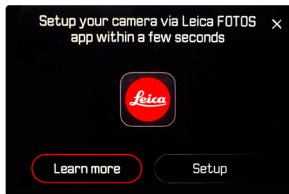

Starting the connection wizard

→ Select **Setup** or **Learn more**

Exiting the connection wizard

→ Tap the icon in the top right corner of the screen

VIA LEICA FOTOS CABLE (for iPhone only)



→ Select **iOS**

• The following screen appears.

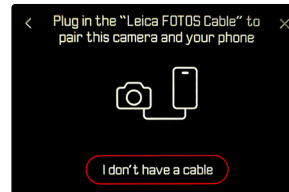

→ Connect the camera and mobile device via the Leica FOTOS cable

→ Follow the instructions provided by the Leica FOTOS app

WITHOUT LEICA FOTOS CABLE

IN THE CAMERA

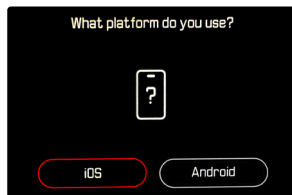

→ Select **iOS**

- The following screen appears.

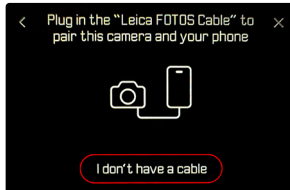

→ Select **I don't have a cable**

→ Select **Next**

ON THE MOBILE DEVICE

→ Launch the Leica FOTOS app

→ Select "Add Camera"

→ Select the camera model

- Connection is being established. The process may take a few seconds.
- Once successfully connected, the Status LED will light briefly, and the camera displays a relevant message.

USING THE MENU TO

Where the connection wizard was not used or other mobile devices should be connected, the same settings are always accessible via the menu item **Leica FOTOS**.

IN THE CAMERA

- Select **Connectivity** in the main menu
- Select **Leica FOTOS**
- Select **Pairing**

ON THE MOBILE DEVICE

- Launch the Leica FOTOS app
- Select “Add Camera”
- Select the camera model
 - Connection is being established. The process may take a few seconds.
 - Once successfully connected, the Status LED will light briefly, and the camera displays a relevant message.

Notes

- The pairing process may take a few minutes to complete.
- Each mobile device only needs to be paired with the camera once. The process adds the device to the list of known devices.
- The Bluetooth function is disabled if the connectivity mode **Off** is selected (see p. 298). **Pairing** will not be available, and the relevant menu item will be grayed out.

CONNECTING WITH PAIRED DEVICES

VIA LEICA FOTOS CABLE (for iPhone only)

The Leica FOTOS Cable makes connectivity particularly easy and quick.

- Connect the camera and mobile device via the Leica FOTOS cable
 - The connection is established automatically.

Note

- USB mode must be set to **Apple MFi** or **Select on Connection** to ensure an automatic connection via the Leica FOTOS Cable.

VIA WI-FI

IN THE CAMERA

- Select **Connectivity** in the main menu
- Select **Leica FOTOS**
- Select **Mode**
- Select **Performance Mode** or **Eco Mode**

ON THE MOBILE DEVICE

- Launch the Leica FOTOS app
- Select the camera model
- Confirm the prompt
 - The camera connects to the mobile device automatically.

CONNECTION - ANDROID

FIRST-TIME CONNECTION TO A MOBILE DEVICE

The connection is established via WLAN. A pairing of the camera and the mobile device is required for a first-time connection to a mobile device. A connection is established via the connection wizard at initial setup of the camera or later via the menu.

CONNECTION WIZARD

The connection wizard appears at initial startup of the camera or after a camera reset. These settings are also available via the menu item **Leica FOTOS**.

The following screen appears after you have selected the language.

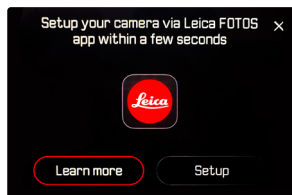

Starting the connection wizard

→ Select **Connect to app**

Exiting the connection wizard

→ Tap the icon in the top right corner of the screen

Going back one step

→ Tap the icon in the top left corner of the screen

IN THE CAMERA



→ Select **Android**

→ Select **Next**

ON THE MOBILE DEVICE

→ Launch the Leica FOTOS app

→ Select "Add Camera"

→ Select the camera model

- Connection is being established. The process may take a few seconds.
- Once successfully connected, the Status LED will light briefly, and the camera displays a relevant message.

USING THE MENU TO

Where the connection wizard was not used or other mobile devices should be connected, the same settings are always accessible via the menu item **Leica FOTOS**.

IN THE CAMERA

- Select **Connectivity** in the main menu
- Select **Leica FOTOS**
- Select **Pairing**

ON THE MOBILE DEVICE

- Launch the Leica FOTOS app
- Select “Add Camera”
- Select the camera model
 - Connection is being established. The process may take a few seconds.
 - Once successfully connected, the Status LED will light briefly, and the camera displays a relevant message.

Notes

- The pairing process may take a few minutes to complete.
- Each mobile device only needs to be paired with the camera once. The process adds the device to the list of known devices.
- The Bluetooth function is disabled if the connectivity mode **Off** is selected (see p. 298). **Pairing** will not be available, and the relevant menu item will be grayed out.

CONNECTING WITH PAIRED DEVICES

IN THE CAMERA

- Select **Connectivity** in the main menu
- Select **Leica FOTOS**
- Select **Mode**
- Select **Performance Mode** or **Eco Mode**

ON THE MOBILE DEVICE

- Launch the Leica FOTOS app
- Select the camera model
- Confirm the prompt
 - The camera connects to the mobile device automatically.

CONNECTIVITY MODES

Three connection options are available.

Factory setting: **Performance Mode**

→ Select **Connectivity** in the main menu

→ Select **Leica FOTOS**

→ Select **Mode**

→ Select **Performance Mode/Eco Mode/Off**

| | Faster connection (Factory setting) | Extended battery life | All RF connections deactivated |
|---|---|---|-----------------------------------|
| | Performance Mode | Eco Mode | Off |
| Bluetooth (Geotagging) | On | On | - |
| Wi-Fi (Data transfer) (Remote control) | The Leica FOTOS connection remains active. | Automatic On / Off The connection to the Leica FOTOS app is established automatically as needed, and disconnected after ≥ 5 min. of inactivity | - |
| Wi-Fi Sleep Timer | Never | After 5 min | - |
| Remote Camera Activation | Always available | This function is available up to 7 days after the camera was switched off | - |

PERFORMANCE MODE

Bluetooth is permanently activated, allowing anytime Geotagging (where enabled). Wi-Fi is similarly permanently activated. This option offers the fastest access to Leica FOTOS and therefore an excellent user experience.

- Select **Connectivity** in the main menu
- Select **Leica FOTOS**
- Select **Mode**
- Select **Performance Mode**

ECO MODE

Bluetooth is permanently activated, allowing anytime Geotagging (where enabled). Camera Wi-Fi will be enabled only during the transfer of settings or files, and will otherwise remain off. This is a power saving option.

- Select **Connectivity** in the main menu
- Select **Leica FOTOS**
- Select **Mode**
- Select **Eco Mode**

AIRPLANE MODE (Off)

All RF connections will be deactivated if this option is selected.

- Select **Connectivity** in the main menu
- Select **Leica FOTOS**
- Select **Mode**
- Select **Off**

EXECUTING A FIRMWARE UPDATE

Any interruption of a running firmware update may cause serious and irreparable damage to your equipment!

You will therefore have to take particular note of the following, when carrying out a firmware update:

- Do not switch off the camera!
- Do not remove the memory card!
- Do not remove the rechargeable battery!
- Do not detach the lens!

Leica FOTOS will notify you when firmware updates are available for your Leica cameras.

- Follow the instructions provided by the Leica FOTOS app

Notes

- A warning message will appear if the battery is insufficiently charged. Recharge the battery and then repeat the process described above.
- Alternatively, firmware updates can also be installed via the camera menu (see p. 295).

REMOTE CAMERA CONTROL

You can take pictures and record video remotely via the mobile device, and can also change image settings or transfer data to the mobile device. A list of available functions and instructions for their use can be found in the Leica FOTOS app.

REMOTE CAMERA ACTIVATION

The camera can be activated remotely from off or standby if this function is activated in the camera. The Bluetooth function must be active.

- Select **Connectivity** in the main menu
- Select **Leica FOTOS**
- Select **Mode**
- Select **Performance Mode/Eco Mode**
 - The camera will scan for known devices and automatically establishes a connection.

Important information

- Remote activation will activate the camera even if it was switched off via the main switch.
- Accidental remote camera activation may result in unwanted pictures taken and excessive power consumption.
- A third-party device can – provided it has been paired with the camera – access the camera remotely if your own mobile device is not currently connected or its Bluetooth function is deactivated. This poses a danger of unauthorized access to your data or camera functions.

Solution

- Only activate this function just before you want to use it.
- Disable the function as soon as it is no longer needed.

CARE/STORAGE

We recommend the following if the camera will not be used for an extended period of time:

- Switch off the camera
- Remove the memory card
- Remove the battery (after approx. 2 months the set date and time will be lost)

CAMERA HOUSING

- Keep your equipment meticulously clean, as any kind of dirt residue presents a breeding ground for micro organisms.
- Only clean the camera with a soft, dry cloth. Stubborn dirt should first be moistened with a watered-down detergent and can then be wiped away with a dry cloth.
- Wet a soft cloth with tap water, wring it out thoroughly and use it to wipe down the camera. Then wipe it down thoroughly with a dry cloth.
- Wipe the camera with a clean, lint-free cloth to remove stains and fingerprints. Tougher dirt in hard to reach corners of the camera housing can be removed with a small brush. Take care not to touch the shutter blades.
- Store the camera in a closed and padded container to prevent friction damage and protect it against dust accumulation.
- Keep the camera in a dry, sufficiently ventilated place, where it will not be subjected to high temperatures and humidity. Make sure to remove all moisture from the camera if it was used in humid conditions.
- Do not store the camera in a leather case for extended periods of time to prevent fungal contamination.
- Empty your camera bag completely if it ever gets wet during use. Your equipment might otherwise be subjected to moisture and tanning residue released by the moist leather.
- All mechanical bearings and sliding surfaces on your camera are lubricated. Remember to press the shutter button several times every three months to prevent the lubrication points hardening if the camera will not be

used for an extended period of time. We also recommend repeated adjustment and use of all the other operating elements.

- When using your camera in tropical climates, make sure to expose the equipment to sunlight and fresh air as much as possible to prevent fungal growth. Storage in airtight containers or cases is recommended only in conjunction with a desiccant like silica gel.

LENS

- A soft-bristle brush will usually suffice to remove dust from the outer lenses. Remove more severe soiling with a clean, soft cloth that is completely free of foreign matter. Wipe the lens in a circular motion from the center outward. We recommend using microfiber cloths that come in a protective container and are available from photography shops and other optical retailers. These cloths are machine-washable at 40°C. Do not use fabric softener and do not iron them. Never use spectacle lens cleaning cloths, as these are soaked in chemicals, which could damage the glass of the camera lenses.
- Attach a transparent UVA filter for optimal front lens protection in unfavorable conditions (e.g. sand, salt water spray). Please remember that the filter may create unwanted light reflections in some backlight situations and in case of high contrasts.
- Lens caps also protect the lens against accidental fingerprint smudges and rain.
- All mechanical bearings and sliding surfaces on your lens are lubricated. Make sure to periodically move the focus ring and the aperture ring to prevent seizing if the lens will not be used for an extended period of time.

VIEWFINDER/LCD PANEL

- Switch off your camera and leave it to stand at room temperature for around 1 hour if condensation has formed on or in the camera. The condensation will disappear, once the camera temperature has reached room temperature.

RECHARGEABLE BATTERY

- Lithium-ion rechargeable batteries should only be stored partially charged, i.e. not fully depleted or fully charged. The camera LCD panel will show the current charge level of the battery. Charge the battery twice a year for around 15 minutes to avoid deep discharge in case of very long storage periods.

MEMORY CARDS

- Make sure to store memory cards in their anti-static container when not in use.
- Do not store memory cards where they will be exposed to high temperatures, direct sunlight, magnetic fields or static electricity. Always remove the memory card if the camera will not be used for an extended period of time.
- We recommend formatting memory cards from time to time, as fragmented residual data from deleted files may block some of the storage capacity.

SENSOR

AUTOMATIC SENSOR CLEANING

Dust residue on sensors can be easily removed. This function causes the sensor to vibrate slightly, which "shakes off" loose dust particles. This function can be accessed and used as needed.

- Select **Camera Settings** in the main menu
- Select **Automatic Sensor Cleaning**
- Select **Yes**
 - Automatic sensor cleaning commences.
 - The camera vibrates for a moment.
 - The message **Please Restart the Camera** appears.
- Switch the camera off and on again

PIXEL MAPPING

Defective pixels may appear on the image sensor of digital cameras over time. The camera compensates for these defective pixels automatically by calculating the data captured by other pixels surrounding defective ones. This feature requires a process known as "pixel mapping" to recognize and register defective pixels. The camera does this automatically every two weeks. The function can also be accessed manually if needed.

- Select **Camera Settings** in the main menu
- Select **Pixel Mapping**
- Select **Yes**
 - Pixel mapping is executed. The process may take a few seconds.
 - The message **Please Restart the Camera** appears.
- Switch the camera off and on again

| Problem | Possible causes to check | Troubleshooting suggestions |
|---|--|---|
| Battery issues | | |
| Battery is depleted too quickly | Battery too cold | Warm the battery (e.g. in pants pocket) and only insert directly before use |
| | Battery too hot | Allow battery to cool down |
| | LCD panel or EVF set too bright | Reduce brightness |
| | Power save mode deactivated | Activate Auto Power Off |
| | AF mode permanently activated | Select other mode |
| | Permanent WLAN connection | Deactivate WLAN when not in use |
| | Continuous use of LCD panel (e.g. in Live View mode) | Deactivate the function |
| | Battery has been recharged too many times | The battery has reached the end of its operating time Replace battery |
| | Tracking-AF with AFc activated | Use AFs or MF |
| | Preview of the recorded images (Auto Review) activated | Deactivate the function |
| Charging process not starting | Incorrect battery polarization or faulty charger connection | Check polarization and connection |
| Charging takes too long | Battery too hot or too cold | Charge the battery at room temperature |
| Charging pilot light is on, but battery isn't charging | The battery contacts are dirty | Clean the contacts with a soft, dry cloth |
| | Battery has been recharged too many times | The battery has reached the end of its operating time Replace battery |
| Camera problems | | |
| The camera suddenly switches itself off | Battery is depleted | Charge or replace the battery |
| The camera won't switch on | Battery is depleted | Charge or replace the battery |
| | Battery too cold | Warming the battery (e.g. in pants pocket) |
| The camera switches off again immediately after it is switched on | Battery is depleted | Charge or replace the battery |
| Camera is heating up | Heat development due to high-res video recording (4K) or serial exposures with DNG | Not a fault; allow camera to cool down if it gets too hot |
| Camera does not recognize the memory card | The memory card is not compatible or defective | Replace the memory card |
| | Memory card is incorrectly formatted | Format the memory card in the camera (Caution: Loss of data!) |

| Menus and displays | | |
|--|---|--|
| Electronic viewfinder is dark | EVF brightness is set too low | Set the EVF brightness |
| Display language is not English | - | Select English in the Language menu |
| Electronic viewfinder is dark | Switchover between EVF and LCD incorrectly set | Select a suitable setting |
| Viewfinder is out of focus | | Check the diopter setting and adjust as needed |
| The LCD panel is too dark or too bright/not clear | The brightness setting is incorrect | Adjust the display brightness |
| | Viewing angle is too small | View the LCD panel at a perpendicular angle |
| | Brightness sensor is blocked | Make sure that the brightness sensor is not blocked |
| Live View stops suddenly or doesn't start | The camera is hot due to high ambient temperature, extended Live View operation, extended video shooting or continuous shooting | Allow camera to cool down |
| The brightness in Live View mode is not the same as in the images | The brightness settings for the LCD panel have no influence over the exposures | Adjust the brightness settings as needed |
| | Exposure preview is deactivated | Activate the function |
| The number of remaining shots does not count down after shooting | The image requires only very little memory space | This is not a fault; the number of remaining shots is calculated as approximations |
| Shooting | | |
| Image noise appears on the LCD panel/ in the viewfinder when the shutter button is pressed to the first pressure point | The gain is increased to aid image composition if the object is insufficiently lit with reduced lens aperture | Not a fault – image quality will not be impacted |
| LCD panel/viewfinder deactivates after a very short time | Power Save settings are activated | Change the settings as needed |
| The display switches off after shooting/the LCD panel goes dark after shooting | Flash loads after shooting, LCD panel deactivates during load time | Wait until the flash is charged |
| Flash won't fire | The flash cannot be used with the current settings | Refer to the list of flash function-compatible settings |
| | Battery is depleted | Charge or replace the battery |
| | Pressing the shutter button while flash is still loading | Wait until the flash is loaded |
| | Electronic shutter function is selected | Change the setting |
| | Automatic bracketing or continuous shooting is activated | Change the setting |
| The flash does not fully illuminate the object | Object is outside the flash range | Move object into flash range |
| | Flash is covered | Make sure the flash unit is not covered by your finger or some object |

| | | |
|--|---|---|
| The camera won't release/shutter button is deactivated/shooting not possible | Memory card is full | Replace the memory card |
| | The memory card is not formatted | Reformat the memory card (Caution: Loss of data!) |
| | The memory card is write protected | Deactivate the write protection on the memory card (small lever on the side of the memory card) |
| | Dirt on the memory card contacts | Clean the contacts with a soft cotton or linen cloth |
| | The memory card is damaged | Replace the memory card |
| | The sensor is overheating | Allow camera to cool down |
| | The camera has switched off automatically (Auto Power Off) | Switch the camera back on Deactivate auto standby as needed |
| | Image data is being written to the memory card and the cache is full | Wait |
| | Noise reduction function is working (e.g. after night photography with long exposure times) | Wait or deactivate noise reduction |
| | Battery is depleted | Charge or replace the battery |
| | Camera is processing a image | Wait |
| Image numbering has reached its limit | See section "Data Management" | |
| Image does not sharpen automatically | AF is deactivated | Activate AF |
| No face detection/faces are not recognized | Face is covered (sunglasses, hat, long hair, etc.) | Remove distracting objects |
| | Face takes up too little space in the picture composition | Change image composition |
| | Face is tilted or horizontal | Keep face straight |
| | Camera not held straight | Hold camera straight |
| | Face is insufficiently lit | Use flash, improve illumination |
| | AF-Override is enabled. That means the user pressed the joystick one time, and Eye/Face/Body Detection was deactivated. | Press the joystick one more time |
| Camera selects incorrect object | The incorrectly selected object is closer to the image center than the main object | Change the image section or take picture using the focus lock |
| | The incorrectly selected object is a face | Deactivate face detection |
| No continuous shooting available | The camera is overheated and the function was temporarily disabled to protect the camera | Allow camera to cool down |
| | An old rechargeable battery (BP-SCL4) is in use | Insert a new rechargeable battery (BP-SCL6) |

| | | |
|--|--|--|
| The image on the LCD panel displays lots of noise | Light enhancement function of the LCD panel in dark surroundings | Not a fault – image quality will not be impacted |
| Image storage takes a long time | Noise reduction is activated for long-term exposures | Deactivate the function |
| | The memory card inserted is slow | Use a suitable memory card |
| Manual white balance is unavailable | The image object is too bright or too dark | |
| Camera does not focus | Desired object part is too close to the camera | Select Macro mode |
| | Desired object part is very far away | Exit Macro mode |
| | Object not suitable for AF | Use Focus lock or select manual focus |
| AF frame is framed in red with activated AF; images out of focus | Focusing was unsuccessful | Try to focus again |
| No AF frame selectable | Focus ring not in AF position | Turn the focus ring to the AF position |
| | Automatic Metering Field Control or Face Detection in AF Mode is selected | Select other control mode |
| | Image review is activated | Deactivate image review |
| | Camera is in Standby mode | Press the shutter button to the first pressure point |
| AF assist lamp does not light up | Camera is in video shooting mode | Change the mode |
| | Function is deactivated | Activate AF |
| Video recording | | |
| No video is recorded | The camera is overheated and the function was temporarily disabled to protect the camera | Allow camera to cool down |
| Video shooting stops | Maximum length of individual video sequence was reached | |
| | The memory card's write speed is too low for the selected video resolution/compression | Insert another memory card or change the storage method |
| L-Log is not selectable in video mode | A 10 bit format was not selected as the video format | Switch to 10 bit format or MOV in video format |
| In video mode, I see ASA instead of ISO, angle instead shutter speed and T-aperture values instead of F-values | Cine was selected as shooting mode | Switch from Cine to Video mode |
| There are visible exposure jumps during zooming | The camera is set to Auto ISO | Activate Floating ISO |
| Review and photo management | | |
| Selected images cannot be deleted | Some of the selected images are write protected | Remove write protection (using the device with which the file was originally set to write protected) |

| | | |
|---|---|--|
| File numbering does not start at 1 | The memory card contains previously stored images | See section "Data Management" |
| The time and date settings are incorrect or are not displayed | The camera has not been in use for an extended period of time (the battery was removed) | Insert a charged battery and configure the correct settings |
| The time and date stamp on images are incorrect | Time settings are incorrect | Set the time correctly Caution: Time settings will be lost if the camera is not used/remains in storage with a depleted battery over an extended period of time |
| The time and date stamp on images are unwanted | Setting was ignored | Cannot be removed in retrospect Deactivate the function as needed |
| Images are damaged or missing | The memory card was removed while the readiness indicator was flashing | Never remove the memory card while the readiness indicator is flashing. Charge the battery. |
| | The memory card formatting is faulty or the card is damaged | Reformat the memory card (Caution: Loss of data!) |
| The most recent image is not displayed on the LCD panel | Preview is deactivated | Activate Auto Review |
| Parts of my video scenes are not fully in the picture | Difference of aspect ratios between camera and playback medium | Set the correct aspect ratio on the camera |
| Image quality | | |
| The image is too bright | Light sensor was covered during shooting | Make sure that the light sensor is not obstructed |
| Image noise | Long exposure times (> 1s) | Activate the noise reduction function for long-term exposure |
| | ISO sensitivity set too high | Decrease ISO sensitivity |
| Unnatural colors | White balance not or incorrectly set | Adjust white balance to light source or adjust manually |
| Round white stains, similar to soap bubbles | Flash photography in a very dark environment: reflections of dust particles | Deactivate the flash |
| Images are out of focus | Lens is dirty | Clean the lens |
| | Lens is obstructed | Make sure that lens is unobstructed |
| | Camera moved during shooting | Use flash |
| | | Mount the camera on a tripod |
| | | Use faster shutter speeds |
| Macro Function | Select the appropriate mode | |

| | | |
|---|---|---|
| Images are overexposed | Flash is activated in bright surroundings | Change the flash mode |
| | Strong light source in the image | Avoid strong light sources in the image |
| | (Half) backlight falling into the lens (also from light sources outside the image range) | Use the lens hood or change to another object |
| | Selected exposure time is too long | Select a shorter exposure time |
| Out of focus/picture stabilizer not functioning | Shooting at a dark location without flash | Use a tripod |
| The image is grainy or there is image noise | ISO sensitivity set too high | Decrease ISO sensitivity |
| Horizontal stripes | Picture was taken with electronic shutter under a light source like a fluorescent lamp | Try shorter shutter speeds |
| Unnatural colors and brightness | Shooting in artificial light or extreme brightness | Set white balance or select correct lighting presets |
| No images are displayed | No memory card inserted | Insert a memory card |
| | The photos were taken with another camera | Transfer the files to another device to view them |
| Images cannot be displayed | File name was changed on a PC | Use suitable software for file transfers from a PC to the camera |
| Video quality | | |
| Video recordings show flickering/stripes | Light source interference in artificial lighting | Select a different frame rate (suitable for the local alternating current (AC) grid frequency) under Video Profiles |
| Camera noise in video recording | The dials were used | Avoid using the dials during video shootings |
| No sound on video recording | Playback volume is set too low | Increase playback volume |
| | Microphone was covered during shooting | Make sure the microphone is not obstructed while shooting video |
| | Speakers are covered | Make sure that speakers are unobstructed during playback |
| | Microphone was deactivated while recording | Activate the microphone |
| Flickering or horizontal stripes in the video recording | CMOS sensors will display this phenomenon when light sources like LED lamps or fluorescent tubes are used | Quality may be improved by selecting a manual shutter speed (e.g. 1/100 s) |

Smartphones/WLAN

| | | |
|--|---|--|
| WLAN connection gets interrupted | Camera deactivates when it overheats (safety feature) | Allow camera to cool down |
| Cannot pair with a mobile device | The camera was already paired with the mobile device | Delete the camera registration from the Bluetooth settings in the mobile device and repeat pairing process |
| Mobile device connection/image transfer not working | The mobile device is too far away | Bring the devices closer to each other |
| | Interference from other devices in the vicinity, e.g. other smartphones or a microwave oven | Increase distance to interfering devices |
| | Interference from multiple mobile devices in the vicinity | Re-establish the connection/disconnect other mobile devices |
| | Mobile device is currently connected to another device | Check connection |
| Camera does not appear on the WLAN configuration screen of the mobile device | Mobile device does not recognize camera | Switch the WLAN function of the mobile device off and on again |

MENU OVERVIEW

FUNCTION BUTTONS

The following control elements are available for direct access (see p. 74).

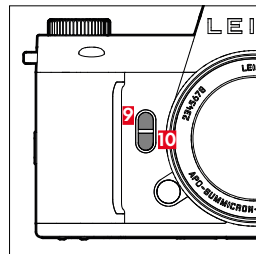
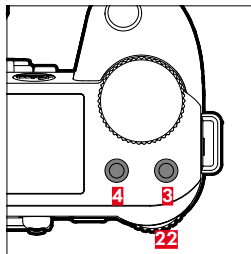
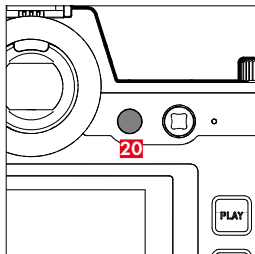
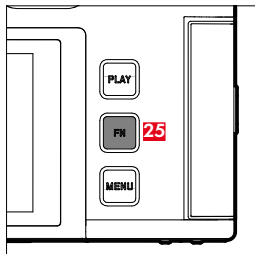

25 FN button

20 Function button

3 Function button

4 Function button

9 Function button

10 Function button

22 Thumbwheel (press)

LEGEND

■ Control Center factory settings

■ Available for Control Center

● Factory setting on the function buttons

● Available for function buttons

DIRECT ACCESS

| FUNCTION | PHOTO | | VIDEO/CINE | |
|-------------------------|----------------|------------------|----------------|------------------|
| | Control Center | Function buttons | Control Center | Function buttons |
| Toggle Info Levels | | ● ● 25 | | ● ● 25 |
| Magnification | | ● ● 9 | | ● |
| Toggle AF/MF | | ● | | ● |
| Toggle Focus Point | | ● | | |
| Exposure/DOF Simulation | | ● | | |
| Headphone Volume | | | ■ | ● ● 9 |
| Wind Noise Reduction | | | | ● |
| Exposure Mode | ■ | ● | ■ | ● |
| Photo <> Video | ■ | ● ● 4 | ■ | ● ● 4 |
| Focus Mode | ■ | ● | ■ | ● |
| AF Mode | ■ | ● ● 10 | ■ | ● ● 10 |
| AF Detection | ■ | ● | ■ | ● |
| Focus Settings | | | | |
| AF Setup | | ● | | ● |
| AF Profiles | ■ | ● | | |
| Focus Aid | | ● | | |
| AF Assist Lamp | | ● | | |
| Auto Magnification | | ● | | ● |
| Touch AF | | ● | | ● |
| Touch AF in EVF | | ● | | ● |
| Focus Limit (Macro) | | ● | | ● |
| Manual Focus Throw | | ● | | ● |

* Some function are available only via direct access. These are listed at the top of the table.

| FUNCTION | PHOTO | | | VIDEO/CINE | | |
|---------------------------------|----------------|------------------|------|----------------|------------------|--|
| | Control Center | Function buttons | | Control Center | Function buttons | |
| Exposure Metering | ■ | ● | | ■ | ● | |
| ISO Settings | ■ | ● | | ■ | ● | |
| Auto ISO Settings | | ● | | | ● | |
| Floating ISO | | ● | | | ● | |
| ISO Increment | | ● | | ■ | ● | |
| EV Increment | | ● | | | ● | |
| Drive Mode | ■ | ● | | | | |
| Continuous Shooting | | ● | | | | |
| Interval Shooting | | ● | | | | |
| Exposure Bracketing | | ● | | | | |
| Multi-Shot | | ● | | | | |
| Self-timer | ■ | ● | | | | |
| White Balance | ■ | ● | ● 3) | ■ | ● | |
| Gray card | | ● | | ■ | ● | |
| Color Temperature | | ● | | | ● | |
| File Format | ■ | ● | | | | |
| JPG Settings | | | | | | |
| Noise Reduction (JPG) | | | | | | |
| iDR | ■ | ● | | ■ | ● | |
| Leica Looks | ■ | ● | | ■ | | |
| Download Leica Look | | ● | | | | |
| Restore | | ● | | | | |
| Noise Reduction (long exposure) | | ● | | | | |
| Perspective Control | ■ | ● | | | | |
| Sensor Format | ■ | ● | | | | |

| FUNCTION | PHOTO | | VIDEO/CINE | |
|-------------------------|----------------|------------------|----------------|------------------|
| | Control Center | Function buttons | Control Center | Function buttons |
| Stabilization | | ● | | ■ |
| Image Stabilization | | ● | | ● |
| Panning Mode | | | | |
| Aspect Ratio | ■ | ● | | |
| Flash Settings | ■ | ● | | |
| Flash Mode | | | | |
| Flash Exp. Compensation | | ● | | |
| Flash Sync | | | | |
| Customize Control | | | | |
| FN Buttons | | ● | | ● |
| Dials | | ● | | ● |
| Joystick | | ● | | |
| Touch Icons (play mode) | | ● | | ● |
| Capture Assistants | | ● | | ● |
| Image Overlay | ■ | ● | | |
| Info Bars | | | | |
| Grids | | | | |
| Clipping / Zebra | | ● | | ● |
| Focus Peaking | | ● | | ● |
| Level Gauge | | | | |
| Histogram | | ● | | |
| Framelines | | | | ● |
| Waveform Monitor | | | | ● |

| FUNCTION | PHOTO | | VIDEO/CINE | |
|------------------------|----------------|------------------|----------------|------------------|
| | Control Center | Function buttons | Control Center | Function buttons |
| Storage Management | | | | |
| Format Storage | ■ | ● | ■ | ● |
| Storage Options | | ● | | ● |
| Shutter Type | ■ | ● | | |
| Auto Review | | ● | | |
| Group Display Mode | | ● | | |
| Live View Settings | | | | |
| Exposure Preview | | ● | | |
| Enhanced Live View | | ● | | |
| Connectivity | ■ | | ■ | ● |
| Leica FOTOS | | ● | | ● |
| Frame.io | | ● | | ● |
| USB Settings | | | | |
| USB Charging | | ● | | ● |
| USB Mode | | | | |
| USB SSD | | | | |
| User Profile | ■ | ● | ■ | ● |
| Camera Settings | | | ■ | |
| Display Settings | | | | |
| EVF <> LCD | | ● | | ● |
| Eye Sensor Sensitivity | | | | |
| LCD Brightness | | | | |
| LCD Color Adjustment | | | | |
| LCD Framerate | | | | |
| EVF Brightness | | | | |

| FUNCTION | PHOTO | | VIDEO/CINE | |
|-------------------------------------|----------------|------------------|----------------|------------------|
| | Control Center | Function buttons | Control Center | Function buttons |
| EVF Color Adjustment | | | | |
| EVF Frame Rate | | | | |
| Rotate Info Bars | | | | |
| Auto Power Off | | | | |
| Displays/AF Auto Off | | | | |
| Power Saving | | | | |
| Auto Power Off | | | | |
| Displays/AF Auto Off | | | | |
| Power Button LED | | | | |
| Battery Condition | | | | |
| Date & Time | | | | |
| Wi-Fi | | | | |
| Reset Camera | | | | |
| Lens Profiles | | ● | | ● |
| Reset Image Numbering | | | | |
| Pixel Mapping | | | | |
| Automatic Sensor Cleaning | | | | |
| Distance Unit | | | | |
| Acoustic Signal | | ● | | ● |
| Camera Information | | | | |
| Leica Content Credentials | | | | |
| Language | | | | |
| Exposure Compensation | ■ | ● | ■ | ● |
| ISO (Photo & Video)* ASA (Cine)* | ■ | ● ● 3 | ■ | ● ● 3 |

| FUNCTION | PHOTO | | | VIDEO/CINE | | |
|----------------------|----------------|------------------|--|----------------|------------------|--|
| | Control Center | Function buttons | | Control Center | Function buttons | |
| Video Profiles | | | | ■ | ● | |
| Log Settings | | | | ■ | ● | |
| HLG Settings | | | | | | |
| L-Log Settings | | | | | ● | |
| LUT Profile | | | | | ● | |
| Cine Mode | | | | | ● | |
| HDMI with Audio | | | | | | |
| Audio | | | | | | |
| Microphone Gain | | | | ■ | ● | |
| Wind Noise Reduction | | | | | ● | |
| Timecode | | | | ■ | ● | |
| Segmented Video | | | | | ● | |
| Color Bar | | | | | ● | |
| REC Frame | | | | | ● | |
| Capture Assistants | | | | | | |
| False Color | | | | | ● | |

DIRECT ACCESS IN REVIEW MODE

| FUNCTION | Review (photo)/Playback (video) | | |
|--------------------------------|---------------------------------|------------------|-------------|
| | Play Menu | Function buttons | |
| Toggle Info Levels | | ● | ● 25 |
| Rate / Unrate | | ● | ● 3 |
| EVF <> LCD | | ● | ● 20 |
| Magnification (photos only) | | ● | ● 10 |
| Delete Single | ● | ● | ● 4 |
| Delete Multi | ● | ● | ● 9 |
| Delete All without ★ | ● | ● | |

TECHNICAL DATA

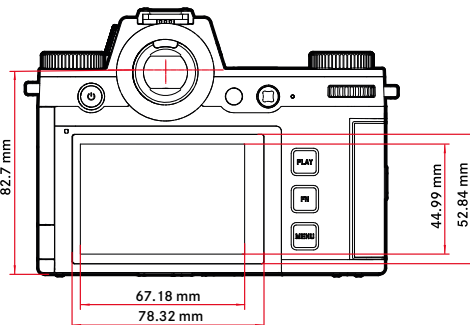
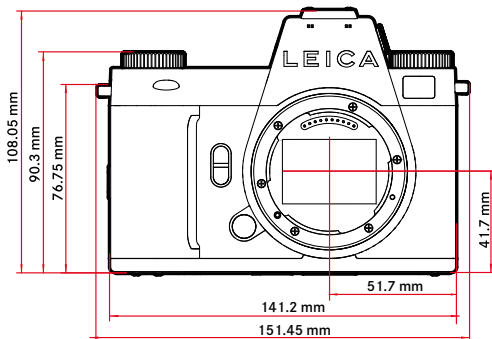
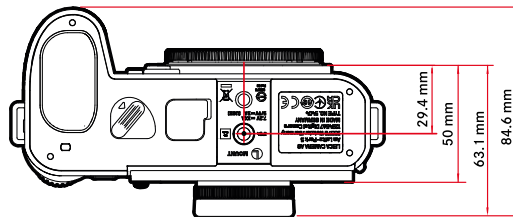
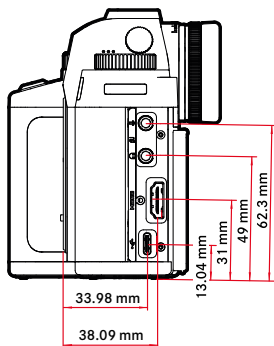

CAMERA

Designation

Leica SL3-P

Camera type

Mirrorless full-frame system camera

Type No.

3403

Order No.

10664 (EU), 10665 (JP), 10666 (ROW)

Buffer memory

8 GB, capacity, depending on frame rate and picture format, estimated quantity (number of possible images in the buffer memory)

| Continuous shooting | DNG | DNG + JPG | JPG |
|---------------------|------|-----------|------|
| 2 fps, 14 bit, AF | 1000 | 275 | 1000 |
| 5 fps, 14 bit, AF | 180 | 95 | 195 |
| 7 fps, 14 bit, AF | 125 | 85 | 130 |
| 15 fps, 14 bit, AF | 70 | 70 | 70 |
| 15 fps, 12 bit, AF | 70 | 70 | 70 |
| 30 fps, 12 bit, AF | 175 | 175 | 175 |
| 25 fps, 14 bit, AF | 70 | 70 | 70 |
| 30 fps, 12 bit, AF | 70 | 70 | 70 |
| 40 fps, 12 bit, AF | 70 | 70 | 70 |

The values refer to a CFexpress Card Type B with the setting **Leica Content Credentials** = **Off**

Storage medium

UHS-II (recommended), UHS-I, SD/SDHC/SDXC card + CFexpress card type B (recommended)

Material

Full metal housing: magnesium and aluminum, leatherette covering, splash water protected in accordance with IEC Standard 60529 (protection type IP54)

Lens mount

Leica L bayonet with contact strip for communication between lens and camera

Operating conditions

-10 to +40°C

Interfaces

- ISO accessory shoe with additional control contacts
- Sync jack / timecode connection
- HDMI jack 2.1 Type A
- USB-C USB3.1 Gen2
- Audio output 3.5 mm/Audio input 3.5 mm
- Communication interface in the bottom cover of the multifunction handgrip

Tripod thread

A 1/4 DIN 4503 (1/4") with stainless steel in the base

Weight

Approx. 768 g (without battery, SD card, body cap)

SENSOR

Sensor size

CMOS sensor, 45.8 MP/44.9 MP (total/effective)

Processor

Leica Maestro series (Maestro IV)

Image stabilization

5-axis image stabilization up to 5-stops

Filter

RGB color filter, UV/IR filter, no low-pass filter

File formats

Photo: DNG™ (raw data), DNG + JPG, JPG (DCF 2.0, Exif 3.00)

Video:

| | | | |
|-----|----------------|------|---------------|
| MP4 | H.265 | AAC | 48 kHz/16 bit |
| | H.264 | AAC | 48 kHz/16 bit |
| MOV | H.265 | LPCM | 48 kHz/24 bit |
| | H.264 | LPCM | 48 kHz/24 bit |
| | ProRes | LPCM | 48 kHz/24 bit |
| RAW | not applicable | LPCM | 48 kHz/24 bit |

Image resolution

| 35 mm | JPG | | DNG | |
|------------|---------------|----------|---------------|----------|
| L | 8144 x 5224 | 44.2 MP | 8144 x 5424 | 44.2 MP |
| S | 6336 x 4208 | 26.7 MP | 6336 x 4218 | 26.7 MP |
| APS-C | JPG | | DNG | |
| L | 5360 x 3568 | 19.1 MP | 5360 x 3568 | 19.1 MP |
| S | 4160 x 2768 | 11.5 MP | 4168 x 2776 | 11.5 MP |
| Multi-shot | JPG | | DNG | |
| L | 16288 x 10848 | 176.7 MP | 16288 x 10848 | 176.7 MP |
| M | 11504 x 7664 | 88.2 MP | - | - |

File size

DNG™: approx. 60 MB (L-DNG), depending on resolution and image content, JPG: approx. 21 MB (L-JPG), depending on resolution and image content

Video: max. length depending on ambient temperature and available memory space

Color depth

DNG™: 14 bit (12 bit also possible depending on the continuous shooting mode), JPG: 8 bit

Color space

Photo: sRGB

Video: Rec. 709/Rec. 2020 (HLG/L-Log)

Shooting Mode Video

Video mode: P - A - S - M

Cine mode: M

Recording time

(no time limit*)

Recording times depend on storage capacity and sensor temperature (*typical recording times at 25°C: 8K/30 fps approx. 20 min, 6K/30 fps approx. 25 min, 4K/30 fps approx. 30 min)

Video Resolution

| | Resolution | Aspect ratio |
|-------|-------------------|--------------|
| 8K OG | 8064 x 5376 (MOV) | 3:2 |
| | 8128 x 5418 (RAW) | 3:2 |
| C8K | 8128 x 4288 (MOV) | 17:9 |
| | 8128 x 4302 (RAW) | 17:9 |

| | | |
|-----------------|-----------------------|------|
| 8K | 7680 x 4320 | 16:9 |
| 7.2K OG | 7200 x 4800 | 3:2 |
| 7.2K | 7232 x 4820 | 3:2 |
| 6.4K OG | 6432 x 4288 | 3:2 |
| C6K | 5760 x 3040 | 17:9 |
| 6K | 5888 x 3312 (H.265) | 16:9 |
| 4.8K | 4752 x 3568 | 4:3 |
| 4.7K | 4736 x 3552 | 4:3 |
| C4K | 4096 x 2160 (MOV/MP4) | 17:9 |
| 4K | 3840 x 2160 | 16:9 |
| Full HD | 1920 x 1080 | 16:9 |
| 2K (Proxy) | 2048 x 1080 | 17:9 |
| 1.9K (Proxy) | 1920 x 1440 | 4:3 |
| 1.9K (Proxy) | 1920 x 1280 | 3:2 |
| Full HD (Proxy) | 1920 x 1080 | 16:9 |

Video frame rate / bit rate

See: "Leica SL3-P Video Specification"

Color space (video) / Video Gamma

Rec. 709, Rec. 2020 (L-Log & HLG)

Further information can be found in the "L-Log Reference Manual" for download on the Leica homepage

VIEWFINDER/LCD PANEL

Viewfinder (EVF)

Resolution: 5,760,000 dots, 60 fps or 120 fps, magnification: approx. 0.76x at aspect ratio: 3:2 / approx. 0.78x at aspect ratio: 4:3, frame coverage: 100%, exit pupil position: 21 mm, setting range -4/+2 dpt, with eye sensor for automatic switchover between viewfinder and LCD panel, time delay 0.005 s

LCD panel

3.2" (backlight LED) with anti-fingerprint and anti-scratch coating, 2,332,800 dots, format 3:2, touch panel

Top display

1.28" highly reflective trans-reflective monochrome LCD, 128 x 128 pixels, viewing angle 120°, anti-fingerprint coating

SHUTTER

Shutter type

Electronically controlled focal plane shutter/electronic shutter

Shutter speeds

Mech. shutter: 30 min to 1/8000 s, electr. shutter function: video: - 1/10000 s (EV levels = 1/2 and 1/3), photo 14 bit: - 1/8000 s, photo 12 Bit: 1/16000 s, flash synchronization: up to 1/200 s

Shutter button

Two-stage

(1st stage: Activation of the camera electronics including autofocus and exposure metering, 2nd stage: Taking the picture)

Self-timer

Delay time: 2 s, 6 s, 12 s or 30 s

Drive mode

Single, Continuous Shooting, Interval Shooting, Exposure Bracketing, Multi-Shot

Continuous shooting:

| Setting | Shutter type | Autofocus mode for continuous shooting |
|--------------------|--------------------------|--|
| 2 fps, 14 bit, AF | Mech. or electr. shutter | AFc, even if AFs or Intelligent AF is selected |
| 5 fps, 14 bit, AF | | |
| 7 fps, 14 bit, AF | | |
| 15 fps, 12 bit, AF | Electr. shutter | |
| 15 fps, 14 bit, AF | | |
| 25 fps, 12 bit, AF | | |
| 25 fps, 14 bit, AF | | |
| 30 fps, 12 bit, AF | | |
| 40 fps, 12 bit, AF | | |

FOCUSING

Focusing range

Lens-dependent

Focus mode

Automatic or manual

With manual setting: optional magnifying glass function (Magnification) and edge marking (Focus Peaking) available as focus assist

Autofocus system

Hybrid-AF due to combination of contrast metering, depth mapping, and phase comparison metering with AF metering points in the sensor.

Autofocus modes

Intelligent AF (automatically refocuses as soon as something changes in the scene), AFs, AFc, AF setting can be saved, optional Touch AF

Autofocus metering methods

Multi-field, Spot (can be shifted), Field (can be shifted and scaled), Zone (can be shifted and scaled), Tracking, Eye/Face/Body Detection, Animal Detection

Autofocus metering fields

Contrast AF: 315 / Phase detection AF: 819

Autofocus detection

Human (Eye/Face/Body), Human (Eye/Face), Animal (Body), Animal (Eye/Body), Car, Car (Parts)

EXPOSURE

Exposure metering

TTL (exposure metering through the lens)

Exposure metering methods

Spot, Center-Weighted, Highlight-Weighted, Multi-Field

Exposure modes

Program AE mode (P)

Aperture-priority mode (A): manual aperture setting

Shutter-priority mode (S): manual shutter-speed setting

Manual (M): manual setting for shutter speed and aperture

Exposure compensation

±3 EV in 1/3 EV increments or 1/2 EV increments

Automatic bracketing

3 or 5 frames, graduations between shoots up to 3 EV, in 1/3 EV increments, additional optional exposure compensation: up to ± 3 EV

ISO sensitivity range

| | Photo | Video | L-Log | HLG |
|----------|-------------------------|-------------------------|------------------------|-------------------------|
| Auto ISO | ISO 100– ISO 200 000 | ISO 100– ISO 100 000 | ISO 400– ISO 50 000 | ISO 400– ISO 100 000 |
| Manual | ISO 50– ISO 200 000 | ISO 100 000 | ISO 50 000 | ISO 400– ISO 100 000 |

Dual Basis ISO setting

| Photo | Photo | Video | L-Log | L-Log (DRB) | HLG |
|----------------|-------------------------|-------------------------|------------------------|-------------------------|--------------------------|
| Low Basis-ISO | ISO 50– ISO 360 | ISO 50– ISO 360 | ISO 200– ISO 720 | ISO 400– ISO 1440 | ISO 400– ISO 1440 |
| High Basis-ISO | ISO 400– ISO 200 000 | ISO 400– ISO 100 000 | ISO 800– ISO 50 000 | ISO 1600– ISO 50 000 | ISO 1600– ISO 100 000 |

White balance

Automatic (Auto), default (Daylight, Cloudy, Shadow, Tungsten, HMI, Fluorescent (warm), Fluorescent (cool), Flash), manual metering (Gray Card (pipette), Gray Card), manual color temperature settings (Color Temperature, 2000 K to 11500 K)

FLASH EXPOSURE CONTROL

Flash unit connector

Via the accessory shoe

Flash sync socket

For flash synchronization (photo mode only)

Attention

Do not connect and use flash units in Video mode!!

Flash sync time

↔ : 1/200 s, slower shutter speeds available, automatic switchover to TTL linear flash mode with HSS-compatible Leica system flash units if sync time is undercut

Flash exposure metering

Using center-weighted TTL pre-flash metering with Leica flash units (SF 26, SF 40, SF 58, SF 60, SF 64) or with system-compatible flash units, remote controlled flash SFC1

Flash exposure compensation

SF 40: ± 2 EV in 1/2 EV increments

SF 60: ± 2 EV in 1/3 EV increments

EQUIPMENT

Microphone

Stereo internal + microphone input 3.5 mm stereo jack

Speaker

Mono internal + headphones output 3.5 mm stereo jack

WLAN

The Leica FOTOS app is required to use the WLAN function. The Leica app is available from the Apple App Store™ or the Google Play Store™.

| | 2.4 GHz | 5 GHz | |
|------------------|---|--|---|
| EU/ US/ CN | IEEE802.11b/g/n: Channel 1–11 (2412–2462 MHz) | Client mode: (For indoor use only) IEEE802.11a/n/ac: Channel 36–64 (5180–5320 MHz) | Access point + client mode: IEEE802.11a/n/ ac: Channel 149–165 (5745– 5825 MHz) |
| JP | | Access point + client mode: (For indoor use only) IEEE802.11a/n/ac: Channel 36–48 (5180–5240 MHz) | Client mode: (For indoor use only) IEEE802.11a/n/ ac: Channel 52–144 (5260– 5720 MHz) |
| ROW | | | - |

Encryption method: WLAN-compatible WPA2™

GPS

Not available everywhere due to country-specific legislation, can be added via the Leica FOTOS app. Data is written to Exif header of the picture files.

Bluetooth

Bluetooth 5.0 LE: Channel 0–39 (2402–2480 MHz)

Menu languages

English, German, French, Italian, Spanish, Portuguese, Russian, Japanese, Simplified Chinese, Traditional Chinese, Korean

POWER SUPPLY

Rechargeable battery (Leica BP-SCL6)

Lithium-ion rechargeable battery, rated voltage: 7.2V (DC); capacity: 2200 mAh (min.); 383 shots (based on CIPA standard, **AF Detection = Off**), 1431 shots (based on CIPA standard with adapted shooting cycle*, measurement conditions: SD UHS I, BP-SCL6, **AF Detection = Off**); manufacturer: Panasonic Energy (Wuxi) Co. Ltd., Made in China

USB-C AC Adapter (Leica ACA-SCL6)

(optional)

Input: AC 100–240V, 50/60 Hz, 0.25 A, automatic switchover; Output: DC 5V/9V, 3 A; Manufacturer: Salom Electric (Xiamen) Co., Ltd., Made in China

Dual Charger (Leica BC-SCL6)

(optional)

Input: DC 5V/3 A, 9V/3 A, automatic switchover; Output: DC 8.4V, 850 mA/1000 mA; Manufacturer: Salom Electric (Xiamen) Co., Ltd., Made in China

Charging via USB

During operation: 9V/3 A (min. 27W)

With camera switched off: 5V/1500 mA (2.5W or greater)

***Cycle 1:** Switch on, 1st shutter release after 5 s, one shot every 3 s, after 10 shots the camera is switched off (**Auto Power Off**) and switched on again after a waiting time of 5 min.

***Cycle 2:** Switch on, 1st shutter release after 5 s, one shot every 3 s, the camera switches off after 50 shots (**Auto Power Off**) and switched back on after a waiting time of 5 min.
These cycles are repeated alternately until the battery is empty.



QuickTime

LEICA CUSTOMER CARE

Please contact the Customer Care department of Leica Camera AG for the maintenance of your Leica equipment and for help and advice regarding Leica products and how to order them. You can also contact the Customer Care department or the repair service provided by your regional Leica subsidiary for repairs or warranty claims.

LEICA GERMANY

Leica Camera AG

Leica Customer Care
Am Leitz-Park 5
35578 Wetzlar
Germany

Phone: +49(0)6441 2080-189

Fax: +49(0)6441 2080-339

Email: customer.care@leica-camera.com

<https://leica-camera.com>

YOUR NATIONAL REPRESENTATIVE

You will find the Customer Care department responsible for your locality on our homepage:

<https://leica-camera.com/en-US/contact>

LEICA AKADEMIE

Have a look at our full seminar program with many interesting workshops on the topic of photography at:

<https://leica-camera.com/en-US/leica-akademie>

Leica Camera AG | Am Leitz-Park 5
35578 WETZLAR | GERMANY
Telephone: +49(0)6441-2080-0
Fax: +49(0)6441-2080-333
www.leica-camera.com

SL3-P/EN/2026/4/1