



LEICA Q3 43

Technical Data.



Designation	Leica Q3 43																								
Camera type	Digital 35 mm compact camera																								
Type No.	6506																								
Order No.	19 084 EU/US/CN, 19 085 JP, 19 086 ROW																								
Buffer memory	8 GB Capacity, depending on frame rate and picture format, estimated quantity (number of possible images in the buffer memory)																								
	<table border="1"> <thead> <tr> <th></th> <th>DNG</th> <th>DNG + JPG</th> <th>JPG</th> </tr> </thead> <tbody> <tr> <td>15 fps</td> <td>63</td> <td>63</td> <td>67</td> </tr> <tr> <td>9 fps</td> <td>70</td> <td>66</td> <td>76</td> </tr> <tr> <td>7 fps</td> <td>74</td> <td>69</td> <td>83</td> </tr> <tr> <td>4 fps</td> <td>83</td> <td>72</td> <td>104</td> </tr> <tr> <td>2 fps</td> <td>164</td> <td>88</td> <td>947</td> </tr> </tbody> </table>		DNG	DNG + JPG	JPG	15 fps	63	63	67	9 fps	70	66	76	7 fps	74	69	83	4 fps	83	72	104	2 fps	164	88	947
	DNG	DNG + JPG	JPG																						
15 fps	63	63	67																						
9 fps	70	66	76																						
7 fps	74	69	83																						
4 fps	83	72	104																						
2 fps	164	88	947																						
Storage medium	UHS-II (recommended), UHS-I, SD/SDHC/SDXC memory card																								
Material	Full metal housing: magnesium die-cast, leather covering, protection type IP52																								
Operating conditions	0°C to +40°C																								
Interfaces	ISO accessory shoe with additional control contacts for Leica flash units, HDMI jack Type D, USB 3.1 Gen 2 Type C up to 10 Gbps																								
Tripod thread	A 1/4 DIN 4503 (1/4") with stainless steel in the base																								

Dimensions

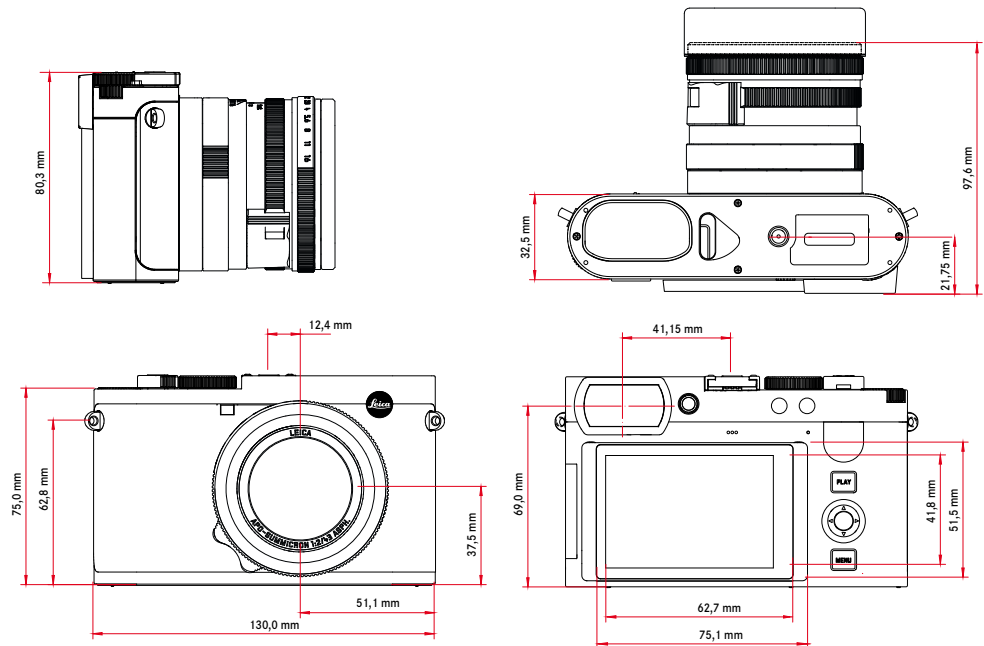

Weight	Approx. 772g/688 g (with/without battery)
--------	---



LEICA Q3 43

Sensor

Sensor size	CMOS sensor, 62.39MP/60.3 MP (total/effective)		
Processor	Leica Maestro series (Maestro IV)		
Filter	RGB color filter, UV/IR filter, no low-pass filter		
File formats	Photo: DNG™ (raw data), DNG + JPG, JPG (DCF 2.0, Exif 2.31) Video:		
	MP4	h.265 h.264	AAC AAC
	MOV	h.265 h.264 ProRes	LPCM LPCM LPCM
			48 kHz/16 bit 48 kHz/16 bit 48 kHz/24 bit 48 kHz/24 bit 48 kHz/24 bit

Image resolution	DNG™	9520x6336 pixels (60.3 MP) 7404x4928 pixels (36.5 MP) 5288x3518 pixels (18.6 MP)
	JPG	9520x6336 pixels (60.3 MP) 7392x4928 pixels (36.4 MP) 5280x3504 pixels (18.5 MP)

File size	DNG™: approx. 70 MB, depending on resolution and image content JPG: depending on resolution and image content Video: max. length: 29 min
-----------	--

Color depth	DNG™: 14 bit JPG: 8 bit
-------------	----------------------------

Color space	Photo: sRGB
-------------	-------------

	RESOLUTION
C8K (17:9)	8192 x 4320
8K (16:9)	7680 x 4320
C4K (17:9)	4096 x 2160
4K (16:9)	3840 x 2160
Full HD (16:9)	1920 x 1080

Video frame rate/bit rate				
MOV C8K				
MOV C8K (recording to SD)				
29.97 fps	C8K 4:2:0 / 10 bit	h.265	L-GOP	300 Mbps
25.00 fps	C8K 4:2:0 / 10 bit	h.265	L-GOP	300 Mbps
24.00 fps	C8K 4:2:0 / 10 bit	h.265	L-GOP	300 Mbps
23.98 fps	C8K 4:2:0 / 10 bit	h.265	L-GOP	300 Mbps
MOV C8K (HDMI output without HLG/L-Log and without recording to SD)				
29.97 fps	8K 4:2:0 / 8 bit	h.265	L-GOP	300 Mbps
25.00 fps	8K 4:2:0 / 8 bit	h.265	L-GOP	300 Mbps
24.00 fps	8K 4:2:0 / 8 bit	h.265	L-GOP	300 Mbps
23.98 fps	8K 4:2:0 / 8 bit	h.265	L-GOP	300 Mbps
MOV C8K (HDMI output with HLG/L-Log or during recording to SD)				
29.97 fps	C4K 4:2:2 / 10 bit	h.265	L-GOP	300 Mbps
25.00 fps	C4K 4:2:2 / 10 bit	h.265	L-GOP	300 Mbps
24.00 fps	C4K 4:2:2 / 10 bit	h.265	L-GOP	300 Mbps
23.98 fps	C4K 4:2:2 / 10 bit	h.265	L-GOP	300 Mbps
MOV 8K				
MOV 8K (recording to SD)				
29.97 fps	8K 4:2:0 / 10 bit	h.265	L-GOP	300 Mbps
25.00 fps	8K 4:2:0 / 10 bit	h.265	L-GOP	300 Mbps
24.00 fps	8K 4:2:0 / 10 bit	h.265	L-GOP	300 Mbps
23.98 fps	8K 4:2:0 / 10 bit	h.265	L-GOP	300 Mbps
MOV 8K (HDMI output without HLG/L-Log and without recording to SD)				
29.97 fps	8K 4:2:0 / 8 bit	h.265	L-GOP	300 Mbps
25.00 fps	8K 4:2:0 / 8 bit	h.265	L-GOP	300 Mbps
24.00 fps	8K 4:2:0 / 8 bit	h.265	L-GOP	300 Mbps
23.98 fps	8K 4:2:0 / 8 bit	h.265	L-GOP	300 Mbps
MOV 8K (HDMI output with HLG/L-Log or during recording to SD)				
29.97 fps	4K 4:2:2 / 10 bit	h.265	L-GOP	300 Mbps
25.00 fps	4K 4:2:2 / 10 bit	h.265	L-GOP	300 Mbps
24.00 fps	4K 4:2:2 / 10 bit	h.265	L-GOP	300 Mbps
23.98 fps	4K 4:2:2 / 10 bit	h.265	L-GOP	300 Mbps



LEICA Q3 43

MOV C4K					
59.94 fps	4:2:2 / 10 bit (SD & HDMI)	h.264	ALL-I	600 Mbps	
50.00 fps	4:2:2 / 10 bit (SD & HDMI)	h.264	ALL-I	600 Mbps	
48.00 fps	4:2:2 / 10 bit (SD)	h.264	ALL-I	600 Mbps	
24.00 fps	4:2:2 / 10 bit (HDMI)				
47.95 fps	4:2:2 / 10 bit (SD)	h.264	ALL-I	600 Mbps	
23.98 fps	4:2:2 / 10 bit (HDMI)				
29.97 fps	4:2:2 / 10 bit (SD & HDMI)	h.264	ALL-I	400 Mbps	
25.00 fps	4:2:2 / 10 bit (SD & HDMI)	h.264	ALL-I	400 Mbps	
24.00 fps	4:2:2 / 10 bit (SD & HDMI)	h.264	ALL-I	400 Mbps	
23.98 fps	4:2:2 / 10 bit (SD & HDMI)	h.264	ALL-I	400 Mbps	
MOV 4K					
59.94 fps	4:2:2 / 10 bit (SD & HDMI)	h.264	ALL-I	600 Mbps	
50.00 fps	4:2:2 / 10 bit (SD & HDMI)	h.264	ALL-I	600 Mbps	
48.00 fps	4:2:2 / 10 bit (SD)	h.264	ALL-I	600 Mbps	
24.00 fps	4:2:2 / 10 bit (HDMI)				
47.95 fps	4:2:2 / 10 bit (SD)	h.264	ALL-I	600 Mbps	
23.98 fps	4:2:2 / 10 bit (HDMI)				
29.97 fps	4:2:2 / 10 bit (SD & HDMI)	h.264	ALL-I	400 Mbps	
25.00 fps	4:2:2 / 10 bit (SD & HDMI)	h.264	ALL-I	400 Mbps	
24.00 fps	4:2:2 / 10 bit (SD & HDMI)	h.264	ALL-I	400 Mbps	
23.98 fps	4:2:2 / 10 bit (SD & HDMI)	h.264	ALL-I	400 Mbps	
MOV FHD					
119.88 fps	4:2:2 / 10 bit (SD & HDMI)	h.264	ALL-I	400 Mbps	
100.00 fps	4:2:2 / 10 bit (SD & HDMI)	h.264	ALL-I	400 Mbps	
59.94 fps	4:2:2 / 10 bit (SD & HDMI)	h.264	ALL-I	200 Mbps	
50.00 fps	4:2:2 / 10 bit (SD & HDMI)	h.264	ALL-I	200 Mbps	
48.00 fps	4:2:2 / 10 bit (SD)	h.264	ALL-I	200 Mbps	
24.00 fps	4:2:2 / 10 bit (HDMI)				
47.95 fps	4:2:2 / 10 bit (SD)	h.264	ALL-I	200 Mbps	
23.98 fps	4:2:2 / 10 bit (HDMI)				
29.97 fps	4:2:2 / 10 bit (SD & HDMI)	h.264	ALL-I	200 Mbps	
25.00 fps	4:2:2 / 10 bit (SD & HDMI)	h.264	ALL-I	200 Mbps	
24.00 fps	4:2:2 / 10 bit (SD & HDMI)	h.264	ALL-I	200 Mbps	
23.98 fps	4:2:2 / 10 bit (SD & HDMI)	h.264	ALL-I	200 Mbps	
MOV FHD Slow Motion					
Sensor: 119.88 fps Recording/Playback: 29.97 fps	4:2:0 / 10 bit (SD & HDMI)	h.265	L-GOP	100 Mbps	
Sensor: 100.00 fps Recording/Playback: 25.00 fps	4:2:0 / 10 bit (SD & HDMI)	h.265	L-GOP	100 Mbps	
MOV FHD ProRes					
59.94 fps	422HQ	ProRes		454 Mbps	
50.00 fps	422HQ	ProRes		378 Mbps	
29.97 fps	422HQ	ProRes		227 Mbps	
25.00 fps	422HQ	ProRes		189 Mbps	
24.00 fps	422HQ	ProRes		182 Mbps	
23.98 fps	422HQ	ProRes		181 Mbps	
MP4 8K					
MP4 8K (recording to SD)					
29.97 fps	8K 4:2:0 / 10 bit	h.265	L-GOP	300 Mbps	
25.00 fps	8K 4:2:0 / 10 bit	h.265	L-GOP	300 Mbps	
23.98 fps	8K 4:2:0 / 10 bit	h.265	L-GOP	300 Mbps	
MP4 8K (HDMI output without recording to SD)					
29.97 fps	8K 4:2:0 / 8 bit	h.265	L-GOP	300 Mbps	
25.00 fps	8K 4:2:0 / 8 bit	h.265	L-GOP	300 Mbps	
23.98 fps	8K 4:2:0 / 8 bit	h.265	L-GOP	300 Mbps	
MP4 8K (HDMI output during recording to SD)					
29.97 fps	4K 4:2:2 / 10 bit	h.265	L-GOP	300 Mbps	
25.00 fps	4K 4:2:2 / 10 bit	h.265	L-GOP	300 Mbps	
23.98 fps	4K 4:2:2 / 10 bit	h.265	L-GOP	300 Mbps	
MP4 4K					
59.94 fps	4:2:0 / 10 bit (SD & HDMI)	h.265	L-GOP	100 Mbps	
50.00 fps	4:2:0 / 10 bit (SD & HDMI)	h.265	L-GOP	100 Mbps	
29.97 fps	4:2:0 / 8 bit (SD & HDMI)	h.264	L-GOP	100 Mbps	
25.00 fps	4:2:0 / 8 bit (SD & HDMI)	h.264	L-GOP	100 Mbps	
23.98 fps	4:2:0 / 8 bit (SD & HDMI)	h.264	L-GOP	100 Mbps	
MP4 FHD					
59.94 fps	4:2:0 / 8 bit (SD & HDMI)	h.264	L-GOP	28 Mbps	
50.00 fps	4:2:0 / 8 bit (SD & HDMI)	h.264	L-GOP	28 Mbps	
29.97 fps	4:2:0 / 8 bit (SD & HDMI)	h.264	L-GOP	20 Mbps	
25.00 fps	4:2:0 / 8 bit (SD & HDMI)	h.264	L-GOP	20 Mbps	
23.98 fps	4:2:0 / 8 bit (SD & HDMI)	h.264	L-GOP	24 Mbps	



LEICA Q3 43

Lens

Designation	Leica APO-Summicron 43 f/2 ASPH., 11 lenses in 8 segments, 7 aspherical lens areas
Lens filter thread	E49
Digital zoom	Optionally approx. 1.4x (equivalent to 60 mm), approx. 1.7x (equivalent to 75 mm), approx. 2.0x (equivalent to 90 mm), approx. 2.8x (equivalent to 120 mm), or approx. 3.5x (equivalent to 150 mm)
Image stabilization	Visual compensation system for photos and video recordings
Aperture range	F2 to F16 in 1/3 EV increments

MTF-Diagramme

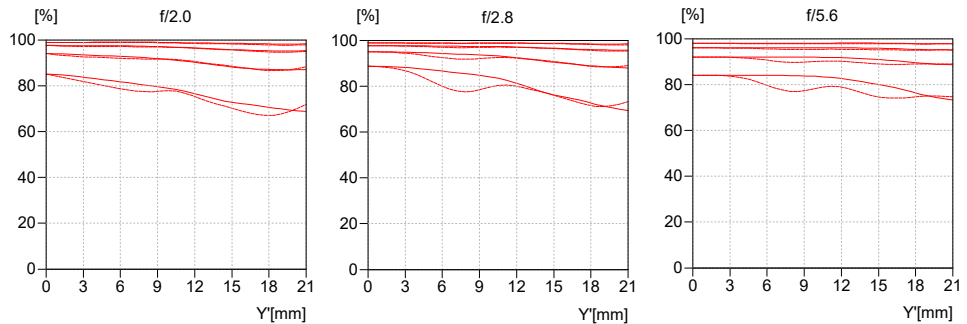

The MTF is shown in each case for the max. aperture as well as for 2.8 and 5.6 for long focus distances (infinity). The contrast is plotted in percentages for 5, 10, 20, 40 Lp/mm over the height of the format for tangential (dashed line) and sagittal structures (continuous line) for white light. The plots for 5 and 10 Lp/mm offer an impression of the contrast behavior for coarser object structures, while the 20 and 40 Lp/mm plots document the resolution capability for fine and finest object structures.

Lens cut

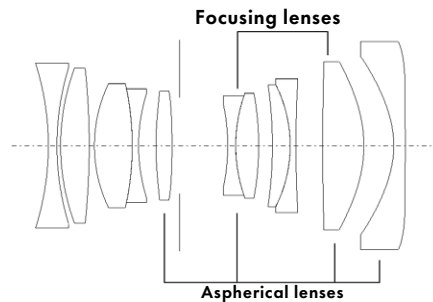

Viewfinder/LCD panel

Viewfinder (EVF)	Resolution: 5,760,000 dots, 120 fps, magnification: 0.79x at aspect ratio: 4:3 / 0.76x at aspect ratio: 3:2, frame coverage: 100%, exit pupil position: 20.75 mm, setting range -4/+2 dpt, with eye sensor for automatic switchover between viewfinder and LCD panel, time delay 0.005 s
LCD panel	3" TFT LCD, approx. 1,843,200 dots, 384 ppi, aspect ratio 3:2, touch panel

Shutter

Shutter type	Mechanical central shutter or optional electronic shutter
Shutter speeds	Mech. shutter: 120 s to 1/2000 s Electro. shutter function: 1 s to 1/16000 s Flash Synchronization: up to 1/2000 s
Shutter button	Two-stage (1st stage: Activation of the camera electronics including autofocus and exposure metering, 2nd stage: Taking the picture)
Self-timer	Delay time: 2 s or 12 s
Drive Mode	Single, Interval Shooting, Exposure Bracketing Continuous Shooting: - 2 fps, 14 bit, AF, 4 fps, 14 bit, AF, 5 fps, 12 bit, AF, 7 fps, 14 bit, AF: Automatic settings (exposure settings in operating modes P/A/S , automatic white balance and autofocus) are <u>implemented individually for each frame</u> . - 9 fps, 12 bit, 15 fps, 12 bit: Automatic settings (exposure settings in operating modes P/A/S , automatic white balance and autofocus) are implemented for the first frame, and are then applied for <u>each subsequent frame</u> in the same picture series.



LEICA Q3 43

Focusing

Focus range	60 cm to ∞ Macro setting: 26.5 cm to 60 cm
Focus mode	Automatic or manual With manual setting: optional magnifying glass function (Auto Magnification) and edge marking (Focus Peaking) available as focus assist
Autofocus system	Hybrid-AF due to combination of contrast metering, depth mapping, and phase comparison metering with AF metering points in the sensor.
Autofocus modes	Intelligent AF (autonomously selects AFs and AFc), AFs , AFc , AF setting can be saved, optional Touch AF
Autofocus metering methods	Spot (can be shifted), Field (can be shifted and scaled), Multi-Field , Zone (can be shifted), Eye/Face/Body Detection , Eye/Face/Body + Animal Detection , Tracking
Autofocus metering fields	315

Exposure

Exposure metering	TTL (exposure metering through the lens), with working aperture									
Metering principle	Exposure metering is done by the image sensor for all exposure metering methods (in Live View mode and in rangefinder mode)									
Exposure metering methods	Spot , Center-Weighted , Highlight-Weighted , Multi-Field									
Exposure modes	Program AE mode (P) Aperture-priority mode (A): manual aperture setting Shutter-priority mode (S): manual shutter-speed setting Manual (M): manual setting for shutter speed and aperture Various fully automated variants (Scene Mode): AUTO , Sport , Portrait , Landscape , Night Portrait , Snow/Beach , Fireworks , Candlelight , Sunset , Digiscoping									
Exposure compensation	±3 EV in 1/3 EV increments									
Automatic bracketing	3 or 5 frames, graduations between shoots up to 3 EV, in 1/3 EV increments additional optional exposure compensation: up to ±3 EV									
ISO sensitivity range	<table border="1"> <thead> <tr> <th></th> <th>Photo</th> <th>Video</th> </tr> </thead> <tbody> <tr> <td>Auto ISO</td> <td>ISO 100–ISO 100 000</td> <td>ISO 100–ISO 100 000</td> </tr> <tr> <td>Manual</td> <td>ISO 50–ISO 100 000</td> <td>ISO 50–ISO 100 000</td> </tr> </tbody> </table>		Photo	Video	Auto ISO	ISO 100–ISO 100 000	ISO 100–ISO 100 000	Manual	ISO 50–ISO 100 000	ISO 50–ISO 100 000
	Photo	Video								
Auto ISO	ISO 100–ISO 100 000	ISO 100–ISO 100 000								
Manual	ISO 50–ISO 100 000	ISO 50–ISO 100 000								
White balance	Automatic (Auto), default (Daylight , Cloudy , Shadow , Tungsten , Flash), manual metering (Gray Card), manual color temperature settings (Color Temperature , 2000 K to 11500 K)									

Flash

Flash unit connector	Via the accessory shoe
Flash sync time	↔ : 1/2000 s, slower shutter speeds available, automatic changeover to TTL linear flash mode with HSS-compatible Leica system flash units if sync time is undercut
Flash exposure metering	Using center-weighted TTL pre-flash metering with Leica flash units (SF 26, SF 40, SF 58, SF 60, SF 64) or with system-compatible flash units, remote controlled flash SF C1
Flash exposure compensation	SF 40: ±2 EV in 1/2 EV increments SF 60: ±2 EV in 1/3 EV increments



LEICA Q3 43

Equipment

Microphone Stereo

Speaker Mono

WLAN WLAN function for connecting to the Leica FOTOS app. The Leica app is available from the Apple App Store™ or the Google Play Store™.

	2.4 GHz	5 GHz	
EU/US/ CN	IEEE802.11b/g/n: channel 1-11 (2412-2462 MHz)	Client mode: (For indoor use only) IEEE802.11a/n/ac: Channel 36-64 (5180-5320 MHz)	Access point + client mode: IEEE802.11a/n/ac: Channel 149-165 (5745-5825 MHz)
JP		Access point + client mode: (For indoor use only) IEEE802.11a/n/ac: Channel 36-48 (5180-5240 MHz)	Client mode: (For indoor use only) IEEE802.11a/n/ac: Channel 52-144 (5260-5720 MHz)
ROW			

Maximum output (e.i.r.p.): <14 dBm, encryption method: WLAN-compatible WPA2™ or WPA2™/WPA3™ (Transition)

Bluetooth Bluetooth 5.0 LE: Channel 0-39 (2402-2480 MHz), maximum output (e.i.r.p.): 10 dBm

GPS Not available everywhere due to country-specific legislation; can be added via the Leica FOTOS app. Data is written to Exif header of the picture files.

Menu languages English, German, French, Italian, Spanish, Portuguese, Russian, Japanese, Traditional Chinese, Simplified Chinese, Korean

Power supply

Rechargeable battery (Leica BP-SCL6) Lithium-ion rechargeable battery, rated voltage: 7.2 V (DC); capacity: 2200 mAh (min.), 350 shots (based on CIPA standard, with Displays/Af Auto Off = 5 s); manufacturer: Panasonic Energy (Wuxi) Co. Ltd., Made in China

Charger (Leica BC-SCL4)* Input: AC 100-240 V, 50/60 Hz, 0.25 A, automatic switchover; output: DC 8.4 V 0.85 A; manufacturer: Salom Electric (Xiamen) Co., Ltd., Made in China

Charging via USB During operation: 9 V/3 A (min. 27 W)
With camera switched off: 5 V/1500 mA (2.5 W or greater)

Wireless Charging Optimal performance with 9 V chargers (10 W Charging Pad* required)

Rated values for input voltage/power 7.2 V == 2.3 A (battery), 5 V == 3.0 A / 9 V == 2.5 A (USB)



QuickTime

*Optional accessory