



LEICA CINE 1
The Art of
Home Cinema.

LEICA CINE 1 – AN HOMAGE TO THE HISTORY OF FILM.



Oskar Barnack



Ur-Leica

Wetzlar, Germany, is the home of the Leica camera and birthplace of the Ernst Leitz Company, the predecessor of today's Leica Camera AG. The connection between Leica and cinema has existed since the very beginning, when Oskar Barnack, the chief developer at Leitz, invented the 35 mm standard. Barnack's idea was to use 35 mm motion picture film for his photography camera, as it was much cheaper, lighter, and smaller than the glass plates in use at the time. It was as early as 1913 when the first record can be found in his workshop notebook, stating: "Lilliput camera for cinema films completed." Through this groundbreaking invention, the dynamics, and vitality of the new cinema genre have influenced photography to this day. Above all, however, the precise Leica premium lenses were crucial for the new image quality.

In 1926, one year after the introduction of the first 35 mm camera, Ernst Leitz introduced the world's first mass-produced projector for 35 mm film – the Leica Pradovit projector. Decades later, these legendary projectors that were manufactured in Germany are still in use today. After more than 80 years of experience in slide projector production, Leica Camera AG presented the first digital Leica projector, the Pradovit D-1200, in the autumn of 2008. No other company in this industry can look back on such a long history and wide variety in the construction of projectors. Furthermore, the high-quality Leitz Cine lenses support cinematographers and filmmakers worldwide in masterfully showcasing their visions. The Leica Cine 1 continues the legacy of moving people through images, providing you with the opportunity to experience these magnificent cinematic masterpieces in the unique Leica look – right in your living room.



LEITZ-PARK – EXPERIENCE LEICA.

Leica is not just a name, but an entire world in itself; one that's full of fascination and passion, consistency and uncompromising engineering. It is the epitome of photography that's "Made in Germany". Leica World in the Leitz-Park is a homage to this craft. It serves as a landmark where Leica enthusiasts and visitors from near and far can find inspiration and enthusiasm for Leica photography in all its facets, inviting you to become a part of the brand's world.

Experience changing exhibitions in the Leica Gallery, gain exciting insights into the manufacturing process, the history of the company and the milestones in product development. Be inspired: in the shops, the hotel, the café, and the restaurants. Visit the Ernst Leitz Museum, browse through the exhibition, the virtual archive – and immerse yourself in the captivating history of the company!





THE NEW CLASSIC.

Refined and timeless. Sustainable design combines meticulous craftsmanship with classic shapes and high-quality materials to create a precise product. Leica Cine 1: an amalgamation of Bauhaus, authentic Leica character and the highest engineering skills. Built for generations, optimised for the screen and designed for stylish living spaces.

ICONIC DESIGN.

Linear shapes, precise craftsmanship and sophisticated functions focused on the essentials: Leica Cine 1 follows Leica's purist design philosophy in every detail. From the durable aluminium housing, to the automatic dust cover, to the perforated speaker cover, right down to the integration of the iconic red dot – original Leica.

LEICA QUALITY IN CINEMA TV.

The RGB laser technology, combined with 4K and Leica Image Optimization (LIO™), ensures an exceptionally natural colour reproduction and nuanced colour gradations. A brightness of up to 3,000 ANSI lumens and an impressive colour space of over 100% in the BT.2020 standard guarantee excellent contrast and high colour depth, even in daylight.





PURIST. ICONIC. TIMELESS.

Modern design meets the highest standards in form and function: the sustainable, elegant aluminium housing in an authentic Leica look focuses on a typically reduced visual language, integrating the Leica Cine 1 as a classic design object in any living room. Thanks to the ultra-short distance lens, it can be combined with the interior in a space-saving and elegant way at a minimal distance from the wall.

ALL-IN-ONE ENTERTAINMENT SYSTEM.

Full cinema experience, intelligent solutions: Leica Cine 1 offers all the state-of-the-art functions of a classic smart TV – from the intuitive Google TV user interface inclusive Google Assistant, an integrated TV tuner, Apple AirPlay, to direct access to your streaming platforms. Whether it's a series, a film, or your own personal library, the Leica Cine 1 combines maximum connectivity with the benefits of the Dolby Atmos® surround sound and Dolby Vision®. Another asset is the Film-maker Mode™, which displays films how the director intended.

VIBRANT FILM PROJECTIONS FROM THE SHORTEST DISTANCE.

Sharp contrasts and natural colours to the edge: From a wall distance of only about 25 cm (ca. 10 inches) with a 100 inches screen size, the ultra-short throw projector of the Leica Cine 1 creates every film scene in detailed images. Experience breathtaking brilliance, intense colour depth, and the resolution rich in contrast.





SD



Full-HD



4K

BRILLIANT VISUAL WORLDS IN 4K.

The visuals. The sound. The atmosphere. It's the finer details that turn a moment into a scene, a film into an epic story, and a projection into an authentic home cinema experience. In the interplay of reality and fiction, the innovative Leica Cine 1 allows for the highest Leica quality standards to be experienced in moving images of up to 120 inches.

The sophisticated Leica Summicron lens, with its four aspherical lenses, is built according to Leica quality standards. Fixed to the respective image size, it ensures a consistent high imaging performance. Thus enabling the distinctive character and outstanding quality of a Leica image to be realised in 4K resolution.

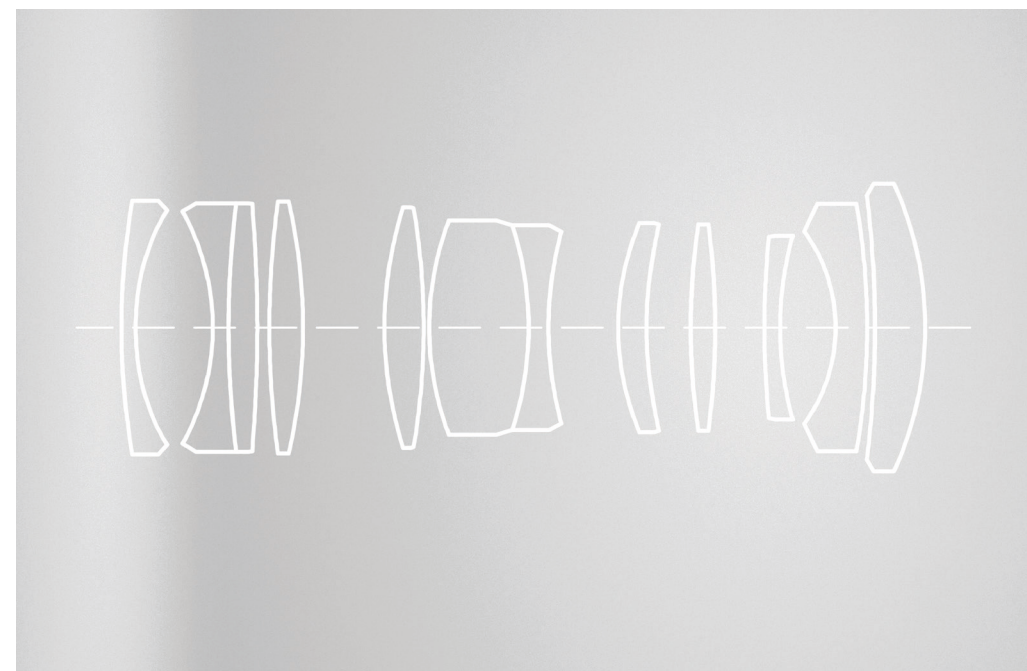
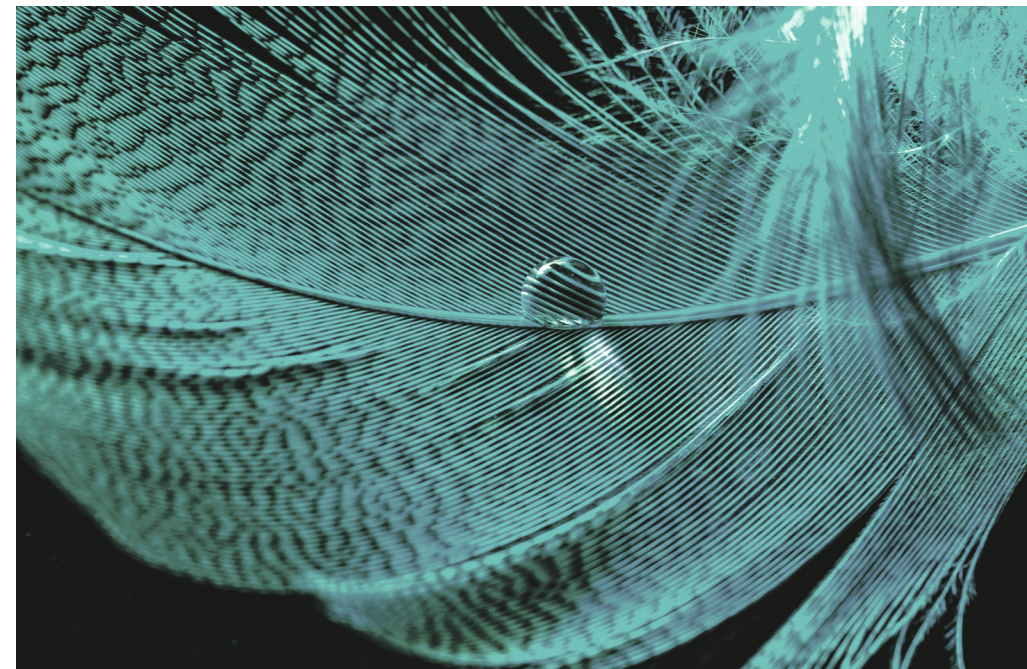

LEICA IMAGE OPTIMIZATION.

Years of expertise in the field of digital image optimization is key to the Leica Cine 1. Leica Image Optimization (LIO™) refines each image during processing with special algorithms and thus achieves particularly bright and natural colour reproduction, detailed colour gradations and excellent contrast transfer in seamless image sequences.

LEICA SUMMICRON LENS.

From projection to home cinema: the Summicron lens has been an integral part of the Leica portfolio for a long time. Traditionally used in cameras for filming, it is used in the Leica Cine 1 for its high-quality image reproduction. The powerful ultra-short-throw lens with four aspherical lenses is manufactured according to Leica quality standards to ensure consistent high imaging performance. The lens is precisely tailored to a fixed image size. This ensures that the factory settings and fine-tuning are optimally preserved over time, allowing the outstanding quality to be experienced in 4K resolution on screen sizes of up to 120 inches.



HOME CINEMA REDEFINED.

All-in-one: Maximum connectivity, maximum convenience and ease of use with the Leica Cine 1. In addition to the smart TV system from Google TV, the Leica Cine 1 includes an integrated TV tuner, voice control operation, Apple AirPlay, three HDMI and two USB ports. The variety of options makes the Leica Cine 1 an all-in-one entertainment system for all applications, from television and streaming, to projecting your own content and gaming. With over 25,000 hours of laser lamp life and lower energy consumption compared to conventional TVs of a similar size, the Leica Cinema TV also excels in energy efficiency.

DOLBY ATMOS® & DOLBY VISION®.

The integrated Dolby Atmos® system impresses with crystal-clear surround sound, whilst Dolby Vision® ensures the most realistic image reproduction possible with its dynamic image optimization. Together, they offer multi-faceted entertainment for all the senses and create an authentic cinema atmosphere in your living room.



FULL SPECTRUM HOME CINEMA.

The Leica Cine 1 offers direct access to popular streaming services, TV channels, and all external signal sources through the combined Bluetooth and infrared remote control with a long range.

- Netflix
- Amazon Prime Video
- Disney+
- and many more

Whether it's films, TV shows, streaming content, your own film library, or gaming with a refresh rate of up to 60 Hz, the smart TV interface allows for easy and fast playback of all desired content in an intuitive display. Additionally, the apps can be sorted according to personal preferences.



The tactile and visually appealing Bluetooth remote control is simple, yet smart. It has an intuitive design and is made of high-quality aluminium.



FILMMAKER MODE™.

A highlight for cineastes: the Filmmaker Mode™. The optional image mode removes unnecessary image processing effects that are not present in the original, such as interpolation filters, noise reduction or dynamic background noise, thus ensuring that the film is reproduced as accurately as possible.



ROOM CONCEPTS – INNOVATION INSPIRED BY TRADITION.

Kettnaker has been developing and manufacturing modular furniture in Dürmentingen, Germany, for 150 years. Similarly, to Leica, the furniture manufacturer Kettnaker also relies on unique craftsmanship. A wide variety of products and materials make it possible to produce modern furniture made to specification, on the basis of a custom system, therefore creating a unique piece every time. These individual pieces impress with functionality and aesthetics, and above all they reflect the personality

of their owners, just like this specially designed concept furniture for the Leica Cine 1. Made in Germany: Values and quality connect both high-tech and craftsmanship, as well as Leica and Kettnaker, resulting in a combination that complements each other in technique and visually flows together perfectly.

URNS A ROOM INTO A MASTERPIECE.

A modular shelving system made for the diversity of life. Endless design variations form a symbiosis with the Leica Cine 1 and enhance every living space in its own way – unique, special and elegant. A piece of furniture for everything that accumulates over time, the many small things that tell their own stories, and the numerous home cinema experiences that are waiting to be told with the Leica Cine 1.





QUINTESSENTIAL CINEMA VIEWING.

For unique cinema experiences in your own living room, you can choose between motorised pull-up screens, a fixed wall-mounted screen, or direct projection onto the wall. For the best possible projection, Leica recommends the fixed wall-mounted high-contrast screens with ALR function (Ambient Light Rejection) specially designed for the Leica Cine 1. The ALR function ensures that distracting ambient light is filtered out, and the projected light is directed towards the viewer, resulting in even more immersive film experiences.

For those who prefer more flexibility, motorised roll-up screens for short-throw projectors are available. These screens are particularly suitable for installation in furniture and remain hidden when not in use.

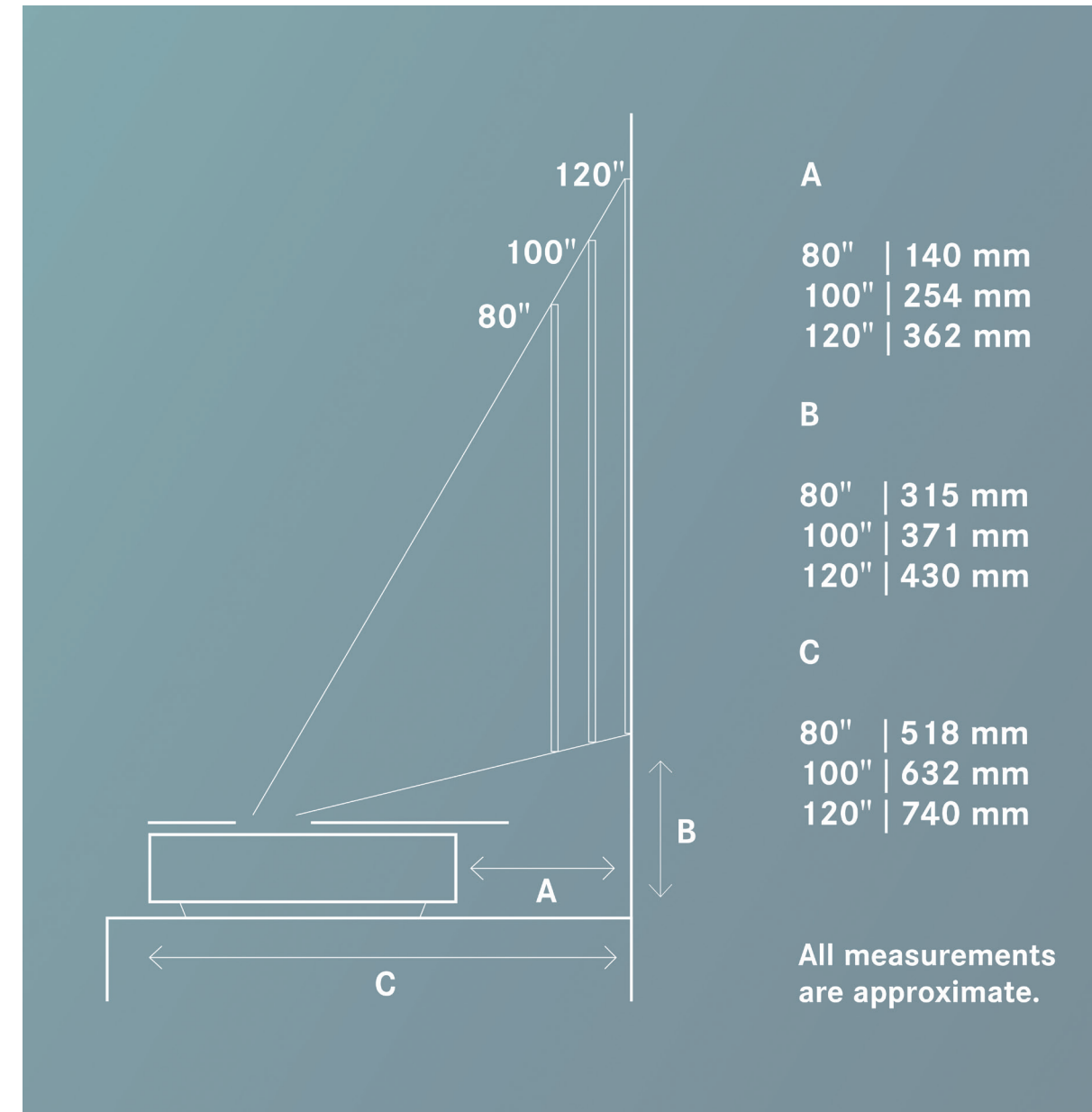

A GRAND CINEMA EXPERIENCE AT HOME.

The combination of excellent video and audio quality creates an authentic, immersive cinema atmosphere. From projection to home cinema experience: Eye-friendly, energy-efficient, and powerful, it captivates with its colour depth and width to the edges through triple RGB laser technology, Leica Image Optimization (LIO™), Leica Summicron lens, 4K resolution, and up to 3,000 ANSI lumens of brightness. This ensures nuanced, vibrant colours and sharp contours even in bright ambient light, delivering an exceptional viewing experience in 100, or 120 inches screen size.

CINEMA TECHNOLOGY
FOR THE HOME.

TECHNICAL DATA.

MODEL NAME	LEICA CINE 1 120	LEICA CINE 1 100	LEICA CINE 1 80
Order No.	EU: 30189 GB: 30190 AUS: 30194 AE: 30191	EU: 30169 GB: 30170 AUS: 30188 AE: 30171	EU: 30163 not available in GB / AUS / AE
Projection Size	120"	100"	80"
DLP	0.47" XPR	0.47" XPR	0.47" XPR
Resolution	3840x2160px (4K)	3840x2160px (4K)	3840x2160px (4K)
Upscaling	Yes	Yes	Yes
Gaming Mode	Yes, Latency < 60 ms 4K@60Hz	Yes, Latency < 60 ms 4K@60Hz	Yes, Latency < 60 ms 4K@60Hz
Lumen Output	Approx. 3000 lm	Approx. 3000 lm	Approx. 2500 lm
Dynamic Contrast	Approx. 2 Mio. :1	Approx. 2 Mio. :1	Approx. 2 Mio. :1
Contrast Ratio	Approx. 1000:1	Approx. 1000:1	Approx. 1000:1
BT.2020 Coverage	> 100 %	> 100 %	> 100 %
HDR Modes	Dolby Vision® / HDR10 / HLG	Dolby Vision® / HDR10 / HLG	Dolby Vision® / HDR10 / HLG
Leica Image Optimization (LIO™)	Yes	Yes	Yes
Throw Ratio	0.25	0.25	0.25
Smart TV	VIDAA 6.0	VIDAA 6.0	VIDAA 6.0
Light Source	Direct Triple RBG-Laser	Direct Triple RBG-Laser	Direct Triple RBG-Laser
Power Consumption Standard Mode / Standby	Max. 300W / 0.5W	Max. 300W / 0.5W	Max. 200W / 0.5W
Voltage	120V - 240V	120V - 240V	120V - 240V
Dimensions LxWxH (console only)	600 x 378 x 149 mm	600 x 378 x 149 mm	600 x 378 x 149 mm
Weight (console only)	Approx. 15.1 kg	Approx. 15.1 kg	Approx. 13.6 kg

TUNER:			
Tuner	DVB-T2 / C / S2 / S with EPG	DVB-T2 / C / S2 / S with EPG	DVB-T2 / C / S2 / S with EPG
Single Cable Distribution DVB-S	Unicable 1 / Unicable Jess	Unicable 1 / Unicable Jess	Unicable 1 / Unicable Jess
DiSEqC	DiSEqC 1.2	DiSEqC 1.2	DiSEqC 1.2

INTERFACES:			
HDMI	2x HDMI 2.1 / 1x HDMI 2.0 Type (1x eARC Support)	2x HDMI 2.1 / 1x HDMI 2.0 Type (1x eARC Support)	2x HDMI 2.1 / 1x HDMI 2.0 Type (1x eARC Support)
USB	2x USB (1x USB 2.0 & 1x USB 3.0)	2x USB (1x USB 2.0 & 1x USB 3.0)	2x USB (1x USB 2.0 & 1x USB 3.0)
USB Recording	Yes	Yes	Yes
LAN (Ethernet RJ45)	1x	1x	1x
Antenna in (RF Tuner)	2x	2x	2x
S/PDIF	1x Optical (Toslink)	1x Optical (Toslink)	1x Optical (Toslink)
Common Interface (CI+)	1x	1x	1x
Earphone/Audio Output	1x	1x	1x

AUDIO:			
Output Power	2 x 25 Watt	2 x 25 Watt	2 x 25 Watt
Dolby Atmos®	Yes	Yes	Yes
Dolby Digital Plus™	Yes	Yes	Yes
Channels	4.0	4.0	4.0

CONNECTIVITY:			
WiFi 6	802.11 AX 2.4 / 5.0 GHz	802.11 AX 2.4 / 5.0 GHz	802.11 AX 2.4 / 5.0 GHz
Works with AirPlay*	Yes	Yes	Yes
Bluetooth	Yes (Version 5.0)	Yes (Version 5.0)	Yes (Version 5.0)
Screen Mirroring	Yes	Yes	Yes

SMART TV:			
Operating System	VIDAA U6	VIDAA U6	VIDAA U6
Voice Assistant	VIDAA Voice	VIDAA Voice	VIDAA Voice
Web Browser	Yes	Yes	Yes
HbbTV	Yes	Yes	Yes
EPG	Yes	Yes	Yes
Child Protection	Yes	Yes	Yes
Noise Reduction	Yes	Yes	Yes
Physical On/Off Button	Yes	Yes	Yes

REMOTE CONTROL:

Remote Control	Bluetooth / IR in Aluminum Housing with Microphone	Bluetooth / IR in Aluminum Housing with Microphone	Bluetooth / IR in Aluminum Housing with Microphone
Voice Command	Yes	Yes	Yes

FILE FORMATS:

AV-Container	AVI / MP4 / MKV / TS / FLV / OGG	AVI / MP4 / MKV / TS / FLV / OGG	AVI / MP4 / MKV / TS / FLV / OGG
Video	AVI / WMV / MP4 / MOV / 3GP / MKV / MPG / MPEG / VOB / FLV / WebM / OGM	AVI / WMV / MP4 / MOV / 3GP / MKV / MPG / MPEG / VOB / FLV / WebM / OGM	AVI / WMV / MP4 / MOV / 3GP / MKV / MPG / MPEG / VOB / FLV / WebM / OGM
Audio	WMA / WMV / MP4 / FLAC / MP2 / MP3 / AAC / WMA / WAV	WMA / WMV / MP4 / FLAC / MP2 / MP3 / AAC / WMA / WAV	WMA / WMV / MP4 / FLAC / MP2 / MP3 / AAC / WMA / WAV
Image	JPEG / BMP / PNG / GIF / WEBP	JPEG / BMP / PNG / GIF / WEBP	JPEG / BMP / PNG / GIF / WEBP

OTHERS:

OTA Software Updates	Yes	Yes	Yes
Operation Temperature	+5°C to +40°C	+5°C to +40°C	+5°C to +40°C
Storage Temperature	-20°C to +65°C	-20°C to +65°C	-20°C to +65°C
Light Source	> 25000 h	> 25000 h	> 25000 h
System Noise	< 32 dB (A)	< 32 dB (A)	< 32 dB (A)

*AirPlay is the trademark of Apple Inc., registered in the US and other countries.

*Google, Google Play, Android TV, Chromecast built-in and other marks are trademarks of Google LLC.

*AirPlay is the trademark of Apple Inc., registered in the US and other countries.



 A trademark of Leica Camera AG.
“Leica” as well as product names = ® registered trademarks
© 2023 Leica Camera AG
Subject to modifications in design, specification, and offer.
Leica Smart Projection GmbH | Am Leitz-Park 5 | 35578 Wetzlar
Phone +49-6442-2080 | leica-cinematv.com

Order Number: German 99022, **English 99023**, French 99024



